

# Optimizing Nsd3-IN-2 incubation time for experiments

**Author:** BenchChem Technical Support Team. **Date:** April 2026

## Compound of Interest

Compound Name: Nsd3-IN-2  
Cat. No.: B11580140

[Get Quote](#)

## Technical Support Center: Nsd3-IN-2

Welcome to the technical support center for **Nsd3-IN-2**, a potent inhibitor of the NSD3 histone methyltransferase. This guide provides troubleshooting advice and frequently asked questions (FAQs) to assist researchers, scientists, and drug development professionals in optimizing their experiments with **Nsd3-IN-2**.

## Frequently Asked Questions (FAQs)

Q1: What is **Nsd3-IN-2** and what is its primary mechanism of action?

A1: **Nsd3-IN-2** is a small molecule inhibitor of the Nuclear Receptor Binding SET Domain Family 3 (NSD3) protein. NSD3 is a histone methyltransferase that specifically di- and trimethylates histone H3 at lysine 36 (H3K36me<sub>2/3</sub>). By inhibiting NSD3, **Nsd3-IN-2** blocks this methylation, which can impact gene expression and cellular processes such as proliferation and differentiation. It has an IC<sub>50</sub> value of 17.97 μM<sup>[1]</sup>.

Q2: What are the key signaling pathways affected by NSD3 inhibition with **Nsd3-IN-2**?

A2: NSD3 is implicated in several oncogenic signaling pathways. Inhibition of NSD3 with **Nsd3-IN-2** is expected to modulate these pathways, including:

- NOTCH Signaling: NSD3-mediated H3K36 methylation can activate the NOTCH signaling pathway, which is crucial for cell fate decisions and is often dysregulated in cancer[2].
- EGFR/ERK Signaling: NSD3 can enhance the activity of the EGFR/ERK pathway, promoting cell proliferation and migration[3][4].
- Wnt/ $\beta$ -catenin Signaling: NSD3 is thought to enhance WNT signaling, a key pathway in development and disease.
- MYC-driven transcription: The short isoform of NSD3 can interact with and stabilize the MYC oncoprotein, a critical regulator of cell growth and proliferation[5].

Q3: How should I reconstitute and store **Nsd3-IN-2**?

A3: For **Nsd3-IN-2**, it is recommended to prepare a stock solution in a solvent like DMSO. For similar inhibitors, stock solutions are typically stored at -20°C for short-term use (up to 1 month) and at -80°C for long-term storage (up to 6 months)[6][7]. Always refer to the manufacturer's datasheet for specific instructions. To prepare a working solution for in vivo experiments, it is advisable to prepare it freshly on the day of use[6].

Q4: What is a good starting concentration and incubation time for my experiments?

A4: The optimal concentration and incubation time for **Nsd3-IN-2** will depend on the cell line and the specific assay. Based on available data, here are some starting recommendations:

- Inhibition of H3K36me3: A concentration of 30  $\mu$ M for 48 hours has been shown to inhibit H3K36me3 expression in non-small cell lung cancer cell lines (H460, H1299, H1560)[1].
- Cell Proliferation Inhibition: For long-term cell proliferation assays, a concentration of 50  $\mu$ M for 7-16 days has been used for H460, H1299, and H1560 cells[1].

It is highly recommended to perform a dose-response and time-course experiment to determine the optimal conditions for your specific experimental setup.

## Experimental Protocols

### Western Blot for H3K36me2/3 Inhibition

This protocol outlines the steps to assess the inhibition of NSD3-mediated H3K36 di- and tri-methylation in cultured cells using Western blotting.

Materials:

- **Nsd3-IN-2**
- Cell culture medium and supplements
- Tissue culture plates
- RIPA buffer with protease and phosphatase inhibitors
- BCA protein assay kit
- SDS-PAGE gels
- PVDF membrane
- Primary antibodies: anti-H3K36me2, anti-H3K36me3, anti-Total Histone H3 (loading control)
- HRP-conjugated secondary antibody
- Chemiluminescence substrate

Procedure:

- **Cell Seeding:** Seed your cells of interest in a 6-well plate at a density that will result in 70-80% confluency at the time of harvest.
- **Treatment:** The next day, treat the cells with varying concentrations of **Nsd3-IN-2** (e.g., 10, 30, 50  $\mu$ M) and a vehicle control (e.g., DMSO).
- **Incubation:** Incubate the cells for a predetermined time (e.g., 24, 48, 72 hours). A 48-hour incubation is a good starting point for observing changes in histone methylation[1].

- **Cell Lysis:** After incubation, wash the cells with ice-cold PBS and lyse them using RIPA buffer containing protease and phosphatase inhibitors.
- **Protein Quantification:** Determine the protein concentration of each lysate using a BCA assay.
- **SDS-PAGE and Transfer:** Normalize the protein amounts for each sample, mix with Laemmli buffer, and boil for 5 minutes. Separate the proteins on an SDS-PAGE gel and transfer them to a PVDF membrane.
- **Antibody Incubation:** Block the membrane with 5% non-fat milk or BSA in TBST for 1 hour at room temperature. Incubate the membrane with primary antibodies against H3K36me2, H3K36me3, and total H3 overnight at 4°C.
- **Detection:** The following day, wash the membrane with TBST and incubate with the appropriate HRP-conjugated secondary antibody for 1 hour at room temperature. After further washes, visualize the protein bands using a chemiluminescence substrate and an imaging system.
- **Analysis:** Quantify the band intensities and normalize the H3K36me2/3 signals to the total H3 signal.

## Cell Viability (MTT) Assay

This protocol describes how to measure the effect of **Nsd3-IN-2** on cell viability using an MTT assay.

Materials:

- **Nsd3-IN-2**
- Cell culture medium and supplements
- 96-well plates
- MTT solution (5 mg/mL in PBS)
- Solubilization solution (e.g., DMSO or a solution of 10% SDS in 0.01 M HCl)

#### Procedure:

- Cell Seeding: Seed cells into a 96-well plate at a density of 5,000-10,000 cells per well in 100  $\mu$ L of medium.
- Treatment: After 24 hours, add 100  $\mu$ L of medium containing various concentrations of **Nsd3-IN-2** (e.g., 0.1, 1, 10, 50, 100  $\mu$ M) and a vehicle control.
- Incubation: Incubate the plate for the desired duration (e.g., 48, 72, 96 hours, or longer for slow-growing cells up to 7-16 days)[1].
- MTT Addition: After the incubation period, add 20  $\mu$ L of MTT solution to each well and incubate for 3-4 hours at 37°C, allowing viable cells to convert MTT to formazan crystals.
- Solubilization: Carefully remove the medium and add 150  $\mu$ L of solubilization solution to each well to dissolve the formazan crystals.
- Absorbance Measurement: Shake the plate for 15 minutes on an orbital shaker to ensure complete dissolution. Measure the absorbance at 570 nm using a microplate reader.
- Data Analysis: Calculate the percentage of cell viability for each treatment group relative to the vehicle control and plot a dose-response curve to determine the IC50 value.

## Data Presentation

Table 1: Recommended Starting Incubation Times and Concentrations for **Nsd3-IN-2**

Assay Type	Cell Lines	Concentration	Incubation Time	Expected Outcome	Reference
Histone Methylation (Western Blot)	H460, H1299, H1560	30 $\mu$ M	48 hours	Reduction in H3K36me3 levels	[1]
Cell Proliferation	H460, H1299, H1560	50 $\mu$ M	7-16 days	Inhibition of cell growth	[1]
Cell Viability (MTT/MTS)	Various	0.1 - 100 $\mu$ M	48 - 96 hours	Dose-dependent decrease in viability	General Protocol

## Troubleshooting Guide

Issue	Possible Cause	Suggested Solution
No or weak inhibition of H3K36 methylation	Inhibitor concentration too low: The IC50 of Nsd3-IN-2 is 17.97 $\mu$ M, but higher concentrations may be needed in cells.	Perform a dose-response experiment with a wider range of concentrations (e.g., 10-100 $\mu$ M).
Incubation time too short: Histone modifications can have a slow turnover rate.	Increase the incubation time (e.g., 72 or 96 hours) and perform a time-course experiment.	
Poor inhibitor stability: The compound may be degrading in the culture medium.	Prepare fresh working solutions of Nsd3-IN-2 for each experiment. If the experiment is long, consider replenishing the medium with fresh inhibitor every 2-3 days.	
Cell line is not sensitive: The target cell line may not rely on NSD3 for H3K36 methylation or may have compensatory mechanisms.	Use a positive control cell line known to be sensitive to NSD3 inhibition. Consider measuring NSD3 expression levels in your cell line.	
High background in Western blot	Non-specific antibody binding: The primary or secondary antibody may be cross-reacting with other proteins.	Optimize antibody concentrations and blocking conditions. Include appropriate controls (e.g., secondary antibody only).
Inconsistent results in cell viability assays	Uneven cell seeding: Variations in the initial number of cells per well can lead to variability.	Ensure a single-cell suspension before seeding and mix the cell suspension thoroughly.

---

Edge effects in 96-well plates: Evaporation from the outer wells can affect cell growth.	Avoid using the outermost wells of the plate for experimental samples. Fill them with sterile PBS or medium instead.	
Inhibitor precipitation: Nsd3-IN-2 may precipitate at high concentrations in aqueous media.	Visually inspect the culture medium for any signs of precipitation. If observed, try using a lower concentration or a different solvent for the stock solution.	
Unexpected cell toxicity	Off-target effects: At high concentrations, the inhibitor may affect other cellular targets.	Perform dose-response experiments and use the lowest effective concentration. Consider using a structurally different NSD3 inhibitor as a control if available.
Solvent toxicity: The vehicle (e.g., DMSO) may be toxic to the cells at the concentration used.	Ensure the final concentration of the solvent in the culture medium is low (typically <0.5%) and include a vehicle-only control.	

---

## Visualizations

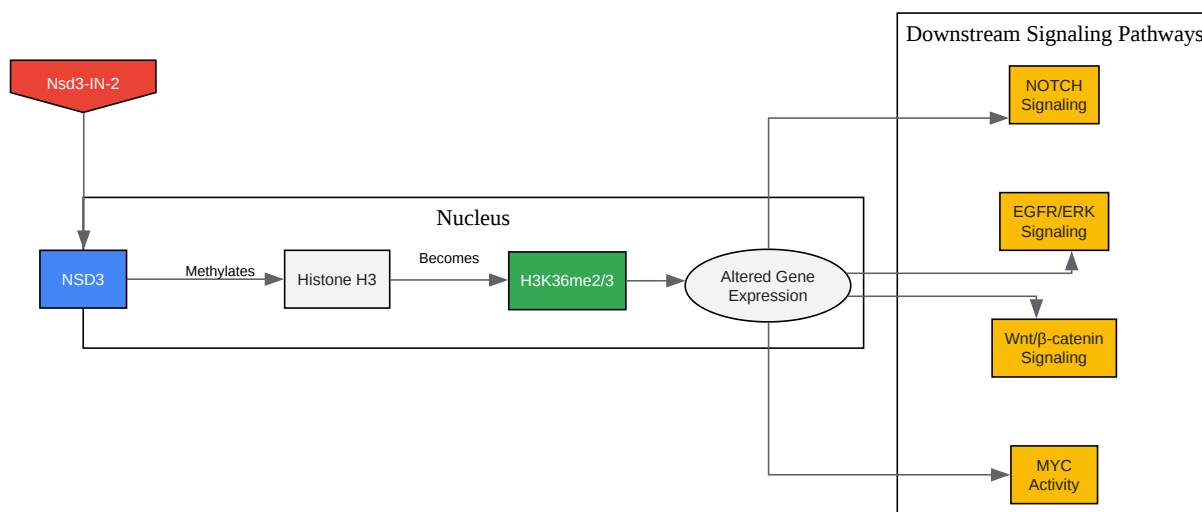

[Click to download full resolution via product page](#)

Caption: NSD3 signaling pathway and the inhibitory action of **Nsd3-IN-2**.

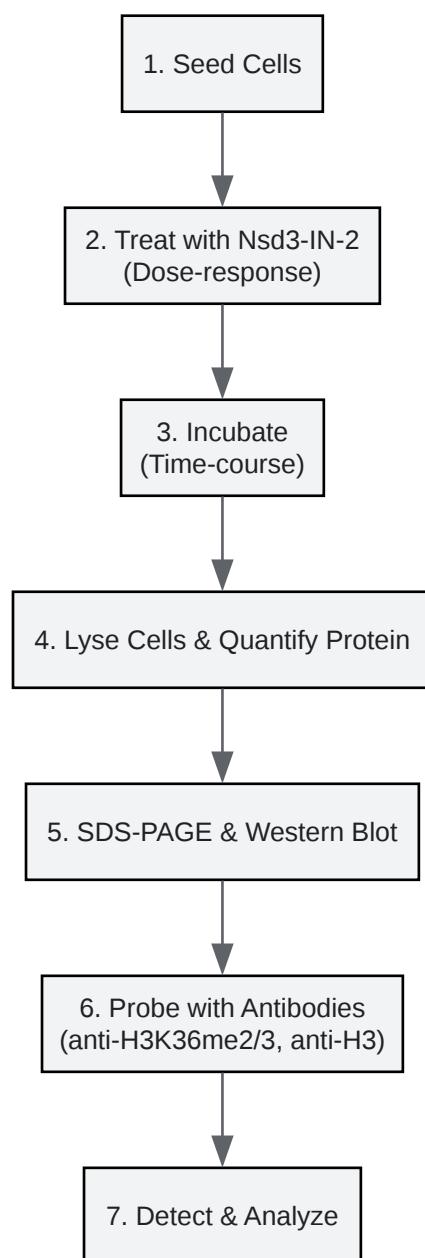

[Click to download full resolution via product page](#)

Caption: Experimental workflow for Western blot analysis of H3K36 methylation.

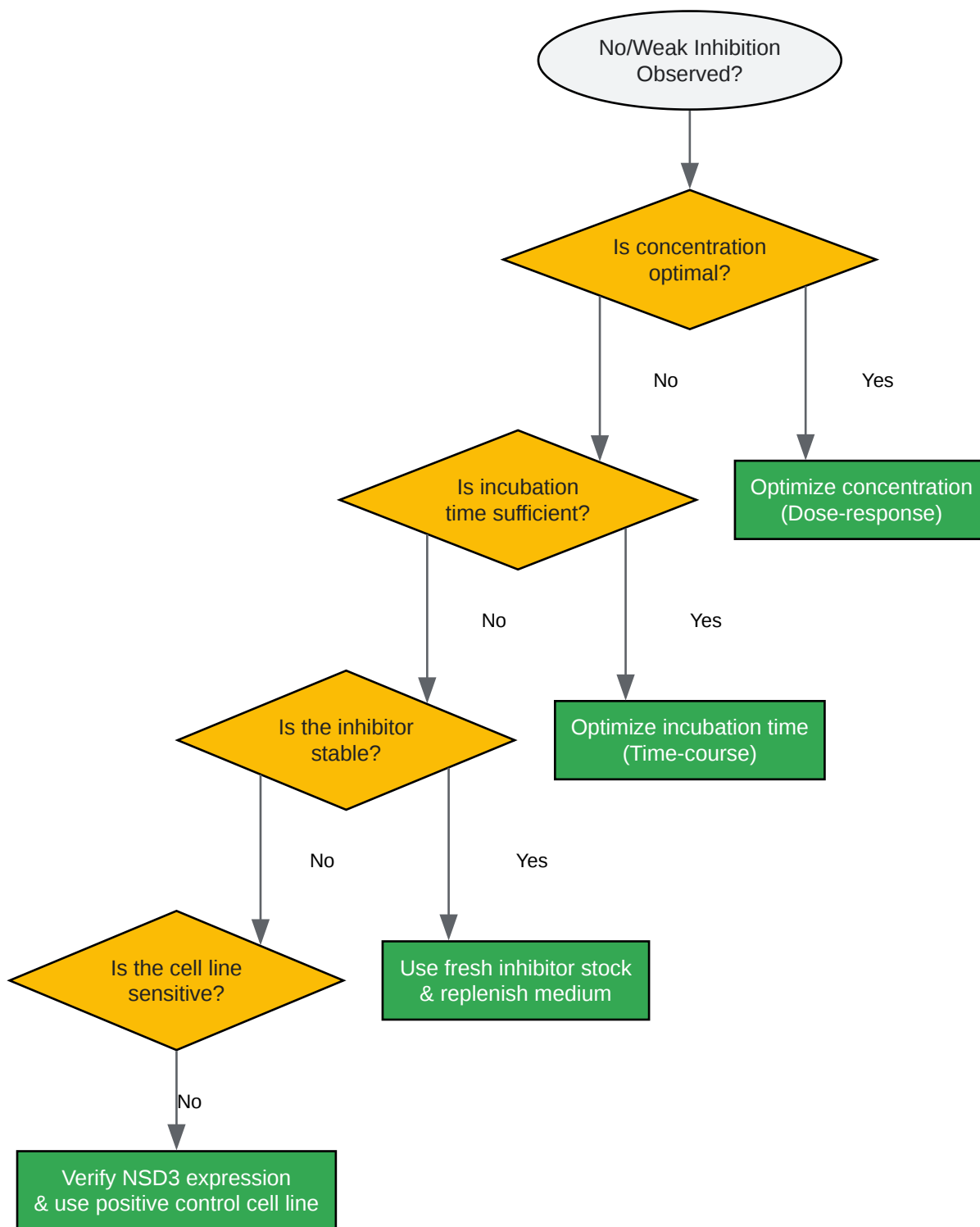

[Click to download full resolution via product page](#)

Caption: Troubleshooting workflow for optimizing **Nsd3-IN-2** experiments.

### Need Custom Synthesis?

BenchChem offers custom synthesis for rare earth carbides and specific isotopic labeling.

Email: [info@benchchem.com](mailto:info@benchchem.com) or [Request Quote Online](#).

## References

- [1. medchemexpress.com \[medchemexpress.com\]](https://www.medchemexpress.com)
- [2. aacrjournals.org \[aacrjournals.org\]](https://www.aacrjournals.org)
- [3. NSD3 in Cancer: Unraveling Methyltransferase-Dependent and Isoform-Specific Functions - PMC \[pmc.ncbi.nlm.nih.gov\]](https://pubmed.ncbi.nlm.nih.gov/31111111/)
- [4. NSD3, a member of nuclear receptor-binding SET domain family, is a potential prognostic biomarker for pancreatic cancer - PMC \[pmc.ncbi.nlm.nih.gov\]](https://pubmed.ncbi.nlm.nih.gov/31111112/)
- [5. dovepress.com \[dovepress.com\]](https://www.dovepress.com)
- [6. medchemexpress.com \[medchemexpress.com\]](https://www.medchemexpress.com)
- [7. medchemexpress.com \[medchemexpress.com\]](https://www.medchemexpress.com)
- To cite this document: BenchChem. [Optimizing Nsd3-IN-2 incubation time for experiments]. BenchChem, [2026]. [Online PDF]. Available at: [\[https://www.benchchem.com/product/b11580140/docs#optimizing-nsd3-in-2-incubation-time-for-experiments\]](https://www.benchchem.com/product/b11580140/docs#optimizing-nsd3-in-2-incubation-time-for-experiments)

---

### Disclaimer & Data Validity:

The information provided in this document is for Research Use Only (RUO) and is strictly not intended for diagnostic or therapeutic procedures. While BenchChem strives to provide accurate protocols, we make no warranties, express or implied, regarding the fitness of this product for every specific experimental setup.

**Technical Support:** The protocols provided are for reference purposes. Unsure if this reagent suits your experiment?

**Need Industrial/Bulk Grade?** [Request Custom Synthesis Quote](#)

# BenchChem

Our mission is to be the trusted global source of essential and advanced chemicals, empowering scientists and researchers to drive progress in science and industry.

## Contact

Address: 3281 E Guasti Rd

Ontario, CA 91761, United States

Phone: (601) 213-4426

Email: [info@benchchem.com](mailto:info@benchchem.com)

[Contact our Ph.D. Support Team for a compatibility check](#)