

Application Notes and Protocols for Determining Apitoxin Concentration in In Vitro Studies

Author: BenchChem Technical Support Team. **Date:** April 2026

Compound of Interest

| | |
|----------------|------------|
| Compound Name: | Apitoxin |
| CAS No.: | 91261-16-4 |
| Cat. No.: | B1158957 |

[Get Quote](#)

For Researchers, Scientists, and Drug Development Professionals

Introduction

Apitoxin, the venom produced by honeybees (*Apis mellifera*), is a complex mixture of bioactive peptides, enzymes, and other compounds. It has garnered significant interest in biomedical research for its potential therapeutic applications, including anti-inflammatory, anti-cancer, and neuroprotective effects.[1] The primary active component of **apitoxin** is melittin, which constitutes a substantial portion of the venom's dry weight.[2] Determining the appropriate concentration of **apitoxin** is a critical first step in designing and interpreting in vitro studies to ensure reproducible and meaningful results. These application notes provide a comprehensive guide to selecting **apitoxin** concentrations, along with detailed protocols for key in vitro assays.

Determining the Optimal Apitoxin Concentration

The effective concentration of **apitoxin** in vitro is highly dependent on the cell type, the duration of exposure, and the specific biological endpoint being investigated. A preliminary dose-response experiment is crucial to determine the optimal concentration range for your specific experimental model.

General Concentration Ranges:

- Anti-inflammatory effects: Concentrations in the lower range, typically 0.1 to 10 µg/mL, are often sufficient to observe anti-inflammatory effects, such as the inhibition of pro-inflammatory cytokine production.[3][4]
- Cytotoxic and anti-cancer effects: Higher concentrations, generally ranging from 1 to 50 µg/mL, are often required to induce cytotoxicity and apoptosis in cancer cell lines.[5][6] It is important to note that at higher concentrations, **apitoxin** can also affect normal, non-cancerous cells.

Data Presentation: Quantitative Effects of Apitoxin on Various Cell Lines

The following tables summarize the half-maximal inhibitory concentration (IC₅₀) values of **apitoxin** and its primary component, melittin, on a variety of cancer and normal cell lines. This data can serve as a starting point for determining the appropriate concentration range for your experiments.

Table 1: IC₅₀ Values of **Apitoxin** in Various Cell Lines

| Cell Line | Cell Type | Exposure Time (h) | IC50 (µg/mL) | Reference |
|---------------|--------------------------------|-------------------|--------------|-----------|
| A549 | Human Lung Carcinoma | 24 | 3.125 | [5] |
| 48 | 2.5 | [5] | | |
| MDA-MB-231 | Human Breast Adenocarcinoma | 24 | 6.25 | [5] |
| 48 | 3.125 | [5] | | |
| Not Specified | 8 | [6] | | |
| HeLa | Human Cervical Carcinoma | 24 | 12.5 | [5] |
| 48 | 6.25 | [5] | | |
| HepG2 | Human Hepatocellular Carcinoma | Not Specified | 12 | [6] |
| NIH3T3 | Mouse Embryonic Fibroblast | Not Specified | 50 | [6] |
| SUM159 | Triple-Negative Breast Cancer | Not Specified | 5.58 ng/µL | [7] |
| SKBR3 | HER2-Enriched Breast Cancer | Not Specified | 5.77 ng/µL | [7] |
| HDFa | Human Dermal Fibroblast | Not Specified | 22.17 ng/µL | [7] |

Table 2: IC50 Values of Melittin in Various Cell Lines

| Cell Line | Cell Type | IC50 (μM) | Reference |
|--|-------------|------------------------|-----------|
| Human TNBC and HER2-enriched breast cancer cells | 0.94 - 1.49 | [7] | |
| Non-transformed cells | 1.03 - 2.62 | [7] | |

Experimental Protocols

This section provides detailed methodologies for key experiments to assess the in vitro effects of **apitoxin**.

Cell Viability and Cytotoxicity Assays

This colorimetric assay is a widely used method to assess cell metabolic activity as an indicator of cell viability.[8]

Protocol:

- **Cell Seeding:** Seed cells in a 96-well plate at a predetermined optimal density (e.g., 1×10^4 to 1×10^5 cells/well) and allow them to adhere overnight.
- **Apitoxin Treatment:** Prepare serial dilutions of **apitoxin** in culture medium. Replace the existing medium with the **apitoxin**-containing medium. Include untreated control wells.
- **Incubation:** Incubate the plate for the desired exposure time (e.g., 24, 48, or 72 hours) at 37°C in a 5% CO₂ incubator.
- **MTT Addition:** Add 10 μL of a 5 mg/mL MTT solution to each well and incubate for 2-4 hours at 37°C, allowing viable cells to metabolize the MTT into formazan crystals.[9]
- **Solubilization:** Carefully remove the medium and add 100 μL of a solubilization solution (e.g., DMSO or a solution of 40% DMF, 2% glacial acetic acid, and 16% SDS) to each well to dissolve the formazan crystals.[8]
- **Absorbance Measurement:** Measure the absorbance at 570 nm using a microplate reader. The absorbance is directly proportional to the number of viable cells.

This assay quantifies the amount of LDH released from damaged cells into the culture medium, serving as an indicator of cytotoxicity.[\[10\]](#)

Protocol:

- **Cell Seeding and Treatment:** Follow steps 1 and 2 of the MTT assay protocol. Include a positive control for maximum LDH release by treating a set of wells with a lysis buffer.[\[11\]](#)
- **Incubation:** Incubate the plate for the desired exposure time.
- **Supernatant Collection:** After incubation, centrifuge the plate at a low speed (e.g., 250 x g for 5 minutes) to pellet the cells. Carefully transfer the supernatant to a new 96-well plate.
- **LDH Reaction:** Prepare the LDH reaction mixture according to the manufacturer's instructions. Add the reaction mixture to each well containing the supernatant.[\[11\]](#)
- **Incubation and Measurement:** Incubate the plate at room temperature for up to 30 minutes, protected from light.[\[11\]](#) Measure the absorbance at the recommended wavelength (typically 490 nm). The amount of color change is proportional to the amount of LDH released.

Apoptosis Assay using Annexin V/Propidium Iodide (PI) Staining and Flow Cytometry

This method distinguishes between viable, early apoptotic, late apoptotic, and necrotic cells.[\[12\]](#)[\[13\]](#)

Protocol:

- **Cell Treatment:** Culture cells in 6-well plates and treat with the desired concentrations of **apitoxin** for the specified duration.
- **Cell Harvesting:** Collect both adherent and floating cells. For adherent cells, gently trypsinize and combine with the floating cells from the supernatant.
- **Cell Washing:** Wash the cells twice with cold phosphate-buffered saline (PBS).

- Staining: Resuspend the cells in 1X binding buffer. Add Annexin V-FITC and Propidium Iodide (PI) to the cell suspension according to the manufacturer's protocol.
- Incubation: Incubate the cells for 15 minutes at room temperature in the dark.
- Flow Cytometry Analysis: Analyze the stained cells by flow cytometry.
 - Viable cells: Annexin V-negative and PI-negative.
 - Early apoptotic cells: Annexin V-positive and PI-negative.
 - Late apoptotic/necrotic cells: Annexin V-positive and PI-positive.

Western Blot Analysis of Signaling Pathways

Western blotting is used to detect and quantify specific proteins involved in signaling pathways modulated by **apitoxin**, such as the NF- κ B, MAPK, and PI3K/AKT pathways.[\[14\]](#)[\[15\]](#)

Protocol:

- Cell Lysis: After **apitoxin** treatment, wash the cells with cold PBS and lyse them using a suitable lysis buffer containing protease and phosphatase inhibitors.
- Protein Quantification: Determine the protein concentration of the cell lysates using a protein assay (e.g., BCA or Bradford assay).
- SDS-PAGE: Denature the protein samples by boiling in Laemmli buffer and separate them by size using sodium dodecyl sulfate-polyacrylamide gel electrophoresis (SDS-PAGE).
- Protein Transfer: Transfer the separated proteins from the gel to a polyvinylidene difluoride (PVDF) or nitrocellulose membrane.
- Blocking: Block the membrane with a blocking solution (e.g., 5% non-fat milk or bovine serum albumin in Tris-buffered saline with Tween 20 - TBST) to prevent non-specific antibody binding.
- Primary Antibody Incubation: Incubate the membrane with a primary antibody specific to the target protein (e.g., p-p65, I κ B α , p-ERK, p-AKT) overnight at 4°C.

- Secondary Antibody Incubation: Wash the membrane and incubate with a horseradish peroxidase (HRP)-conjugated secondary antibody.[14]
- Detection: Detect the protein bands using an enhanced chemiluminescence (ECL) substrate and visualize them using a digital imaging system.[14]
- Analysis: Quantify the band intensities using densitometry software and normalize to a loading control (e.g., β -actin or GAPDH).

Cytokine Production Assay (ELISA)

Enzyme-Linked Immunosorbent Assay (ELISA) is used to quantify the concentration of specific cytokines (e.g., TNF- α , IL-6, IL-1 β) secreted into the cell culture supernatant.[16][17]

Protocol:

- Supernatant Collection: After treating cells with **apitoxin** (and a pro-inflammatory stimulus like LPS if investigating anti-inflammatory effects), collect the cell culture supernatant as described in the LDH assay.
- ELISA Procedure: Perform the ELISA according to the manufacturer's instructions for the specific cytokine of interest. This typically involves:
 - Coating a 96-well plate with a capture antibody.
 - Adding the collected supernatants and standards.
 - Adding a detection antibody.
 - Adding an enzyme-conjugated secondary antibody (e.g., Streptavidin-HRP).
 - Adding a substrate to produce a colorimetric signal.
- Absorbance Measurement: Measure the absorbance at the appropriate wavelength using a microplate reader.
- Data Analysis: Calculate the cytokine concentrations in the samples by comparing their absorbance to the standard curve.[17]

Mandatory Visualizations

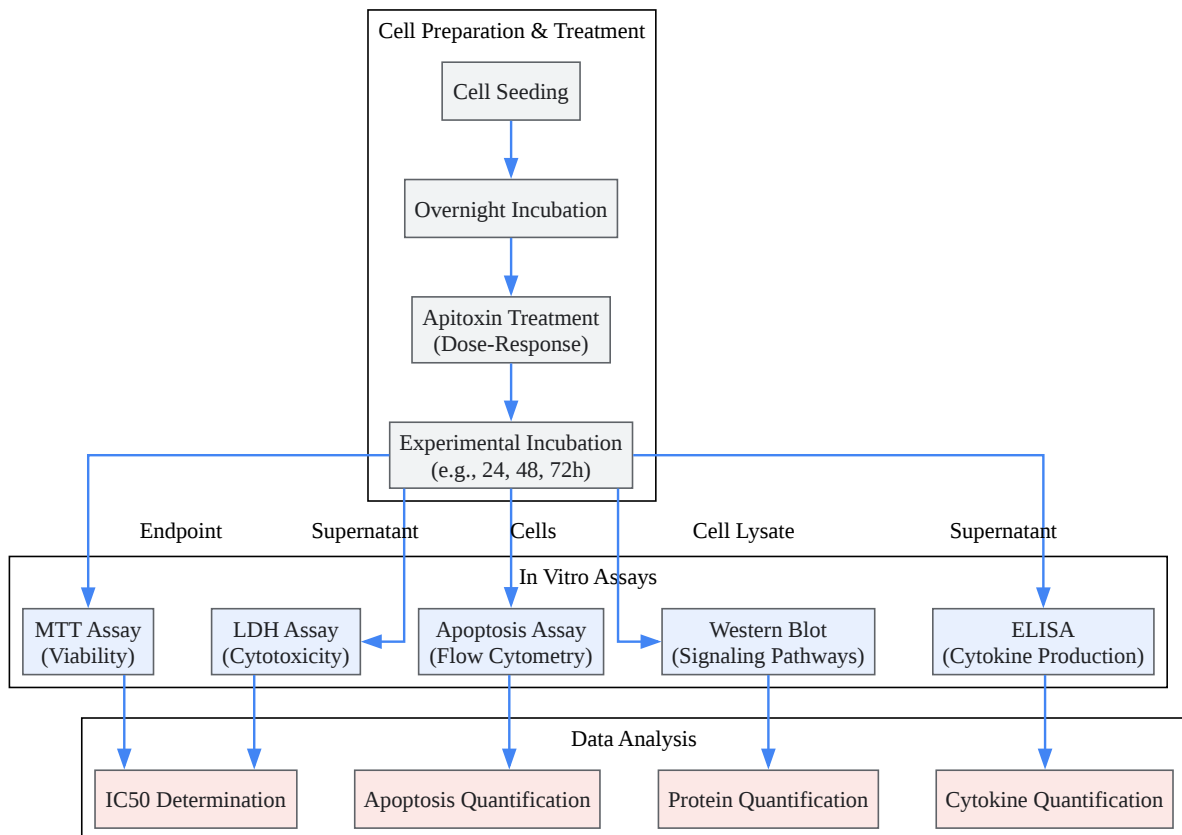

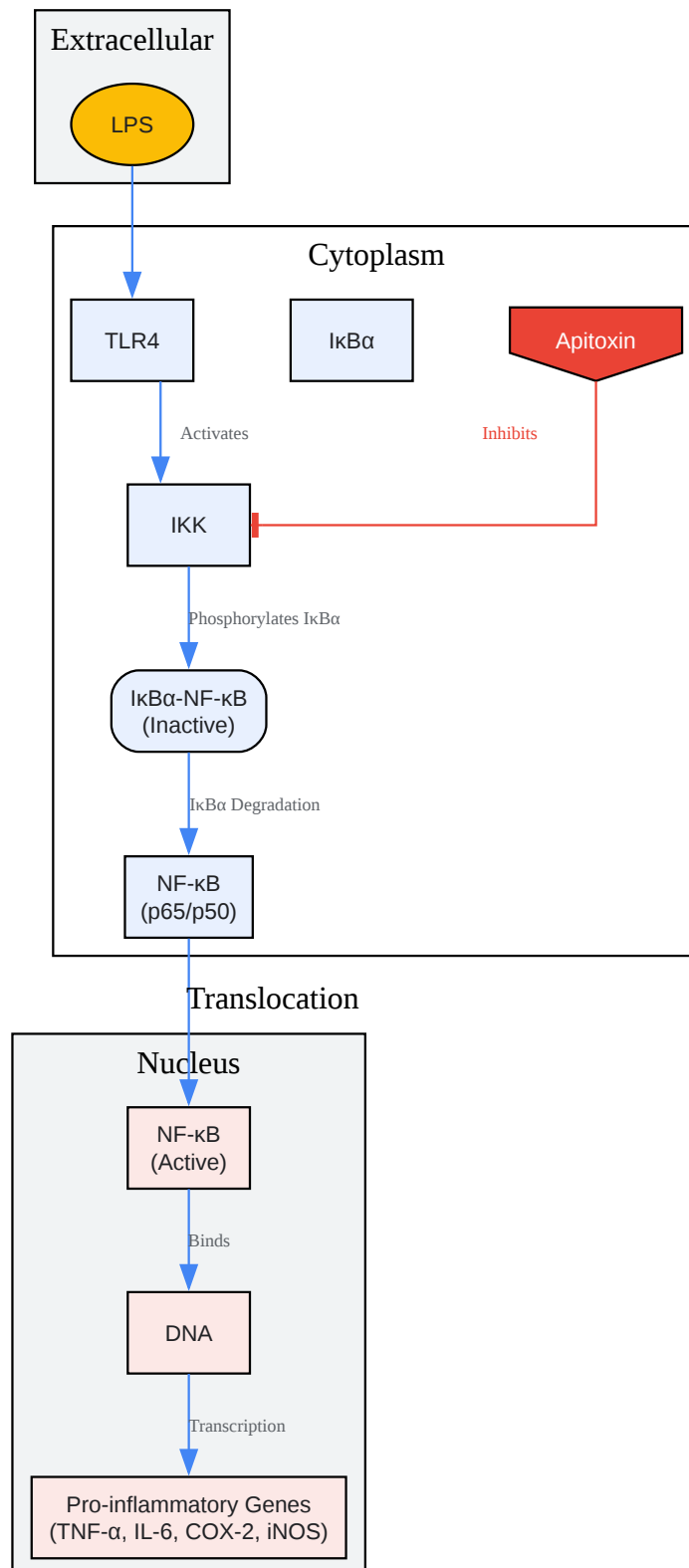

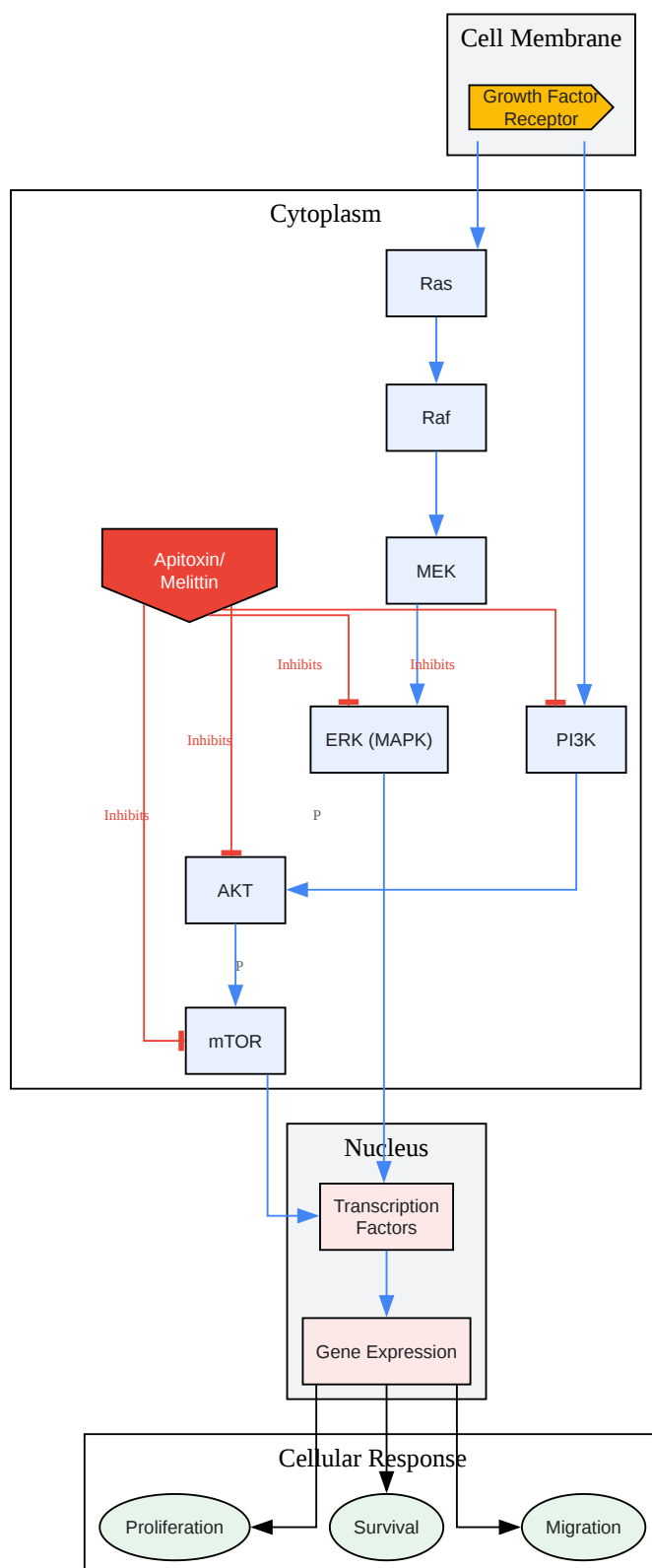

[Click to download full resolution via product page](#)

Need Custom Synthesis?

BenchChem offers custom synthesis for rare earth carbides and specific isotopic labeling.

Email: info@benchchem.com or [Request Quote Online](#).

References

- [1. mdpi.com \[mdpi.com\]](#)
- [2. mdpi.com \[mdpi.com\]](#)
- [3. researchgate.net \[researchgate.net\]](#)
- [4. diposit.ub.edu \[diposit.ub.edu\]](#)
- [5. Cytotoxic Effect of Bee \(*A. mellifera*\) Venom on Cancer Cell Lines - PMC \[pmc.ncbi.nlm.nih.gov\]](#)
- [6. researchgate.net \[researchgate.net\]](#)
- [7. researchgate.net \[researchgate.net\]](#)
- [8. Cell Viability Assays - Assay Guidance Manual - NCBI Bookshelf \[ncbi.nlm.nih.gov\]](#)
- [9. static.igem.wiki \[static.igem.wiki\]](#)
- [10. LDH assay kit guide: Principles and applications | Abcam \[abcam.com\]](#)
- [11. cellbiologics.com \[cellbiologics.com\]](#)
- [12. Protocol for Apoptosis Assay by Flow Cytometry Using Annexin V Staining Method - PMC \[pmc.ncbi.nlm.nih.gov\]](#)
- [13. Protocol for Apoptosis Assay by Flow Cytometry Using Annexin V Staining Method - PubMed \[pubmed.ncbi.nlm.nih.gov\]](#)
- [14. benchchem.com \[benchchem.com\]](#)
- [15. mdpi.com \[mdpi.com\]](#)
- [16. mdpi.com \[mdpi.com\]](#)
- [17. benchchem.com \[benchchem.com\]](#)
- To cite this document: BenchChem. [Application Notes and Protocols for Determining Apitoxin Concentration in In Vitro Studies]. BenchChem, [2026]. [Online PDF]. Available at: [<https://www.benchchem.com/product/b1158957/docs#application-notes-and-protocols-for-determining-apitoxin-concentration-in-in-vitro-studies>]

Disclaimer & Data Validity:

The information provided in this document is for Research Use Only (RUO) and is strictly not intended for diagnostic or therapeutic procedures. While BenchChem strives to provide accurate protocols, we make no warranties, express or implied, regarding the fitness of this product for every specific experimental setup.

Technical Support: The protocols provided are for reference purposes. Unsure if this reagent suits your experiment?

Need Industrial/Bulk Grade? [Request Custom Synthesis Quote](#)

BenchChem

Our mission is to be the trusted global source of essential and advanced chemicals, empowering scientists and researchers to drive progress in science and industry.

Contact

Address: 3281 E Guasti Rd
Ontario, CA 91761, United States
Phone: (601) 213-4426
Email: info@benchchem.com

[Contact our Ph.D. Support Team for a compatibility check](#)