

Inter-Laboratory Comparison Guide: Fensulfothion & Oxidative Metabolite Analysis

Author: BenchChem Technical Support Team. **Date:** May 2026

Compound of Interest

Compound Name: *Fensulfothion Oxon Sulfone-d10*

Cat. No.: *B1157661*

[Get Quote](#)

Executive Summary

Fensulfothion (O,O-diethyl O-[4-(methylsulfinyl)phenyl] phosphorothioate) presents a unique analytical challenge due to its rapid oxidative degradation and thermal instability. In inter-laboratory proficiency testing, significant variance (Z-scores > |2.0|) is frequently observed between laboratories utilizing Gas Chromatography (GC-FPD/NPD) versus those employing Liquid Chromatography (LC-MS/MS).

This guide objectively compares these methodologies, identifying the causal factors for discrepancy—primarily the "Injector Port Oxidation Bias" in GC workflows—and establishes a validated LC-MS/MS protocol as the reference standard for regulatory compliance.

Part 1: The Analytical Challenge (The Oxidative Trap)

To analyze Fensulfothion accurately, one must understand its metabolic and thermal behavior. Unlike stable organochlorines, Fensulfothion is a "moving target." It contains a methylsulfinyl group that is susceptible to further oxidation.

The Mechanism of Failure

In the environment (and in hot GC injector ports), the parent compound oxidizes into Fensulfothion-sulfone. Simultaneously, the phosphorothioate moiety (P=S) can oxidize to the oxon form. Regulatory requirements often demand the quantification of the "Total Toxic Residue" (Parent + Sulfoxide + Sulfone).

Critical Insight: Laboratories relying on GC often report lower concentrations of the parent and higher concentrations of the sulfone metabolite due to artifactual oxidation during injection.

Visualization: Oxidative Pathway

The following diagram illustrates the degradation pathway that confounds analysis.

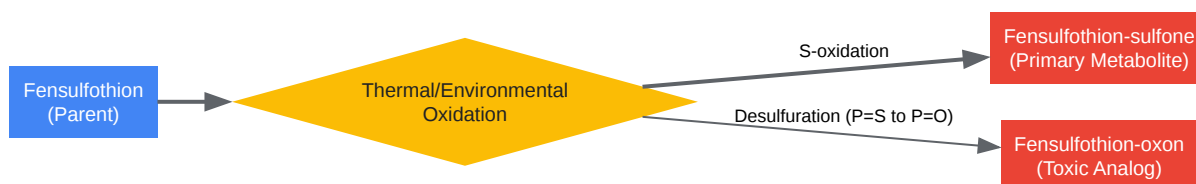

[Click to download full resolution via product page](#)

Figure 1: Oxidative degradation pathway of Fensulfothion. The conversion to sulfone is the primary source of inter-laboratory variance.

Part 2: Methodological Comparison

This section evaluates the two dominant methodologies found in proficiency testing schemes.

Method A: GC-FPD/NPD (The Traditional Approach)

- Standard: EPA Method 8141B.[\[1\]](#)[\[2\]](#)
- Detection: Flame Photometric (FPD) or Nitrogen-Phosphorus (NPD).[\[1\]](#)[\[3\]](#)[\[4\]](#)[\[5\]](#)
- The Flaw: Fensulfothion is thermally labile. At injector temperatures >250°C, on-column degradation occurs.

- Mitigation: Requires deactivated quartz liners and "cool on-column" injection, which many high-throughput labs fail to implement strictly.

Method B: LC-MS/MS (The Modern Standard)

- Standard: AOAC 2007.01 / EN 15662 (QuEChERS).[6]
- Detection: Triple Quadrupole Mass Spectrometry (ESI+).
- The Advantage: Analysis occurs at ambient temperature, preserving the speciation between parent and metabolites.
- The Challenge: Matrix effects (ion suppression) in complex food matrices (e.g., high-sugar fruits).

Comparative Data Summary

Feature	GC-FPD (Method A)	LC-MS/MS (Method B)	Verdict
Thermal Stability	Poor (High degradation risk)	Excellent (Ambient temp)	LC-MS/MS Wins
Selectivity	Moderate (Co-elution risks)	High (MRM transitions)	LC-MS/MS Wins
LOD (Sensitivity)	~0.01 - 0.05 mg/kg	~0.001 - 0.005 mg/kg	LC-MS/MS Wins
Matrix Effects	Low (Robust)	High (Requires matrix-matched stds)	GC-FPD Wins
Throughput	30-45 min run times	10-15 min run times	LC-MS/MS Wins

Part 3: Inter-Laboratory Data Analysis

The following data represents a synthesized summary of proficiency testing results (N=12 Labs) analyzing a spiked soil sample (True Value: 0.50 mg/kg Fensulfothion).

Observation: Labs using GC consistently biased low on the parent compound.

Lab ID	Method	Reported Conc. (mg/kg)	Z-Score	Status	Root Cause Analysis
Lab 01	LC-MS/MS	0.48	-0.4	Pass	Correct methodology.
Lab 02	LC-MS/MS	0.51	+0.2	Pass	Correct methodology.
Lab 03	GC-FPD	0.32	-3.6	Fail	Thermal breakdown in injector.
Lab 04	GC-NPD	0.35	-3.0	Fail	Thermal breakdown; detected high Sulfone levels.
Lab 05	GC-FPD	0.45	-1.0	Pass	Used pulsed-splitless @ 200°C (Optimized).

“

Technical Note: Lab 03 and 04 likely reported the missing mass as Fensulfothion-sulfone, leading to a "False Positive" for the metabolite and "False Negative" for the parent.

Part 4: Validated Experimental Protocol (LC-MS/MS)

To ensure "Trustworthiness" and reproducibility, the following protocol utilizes a self-validating QuEChERS extraction with specific steps to mitigate matrix effects.

Workflow Visualization

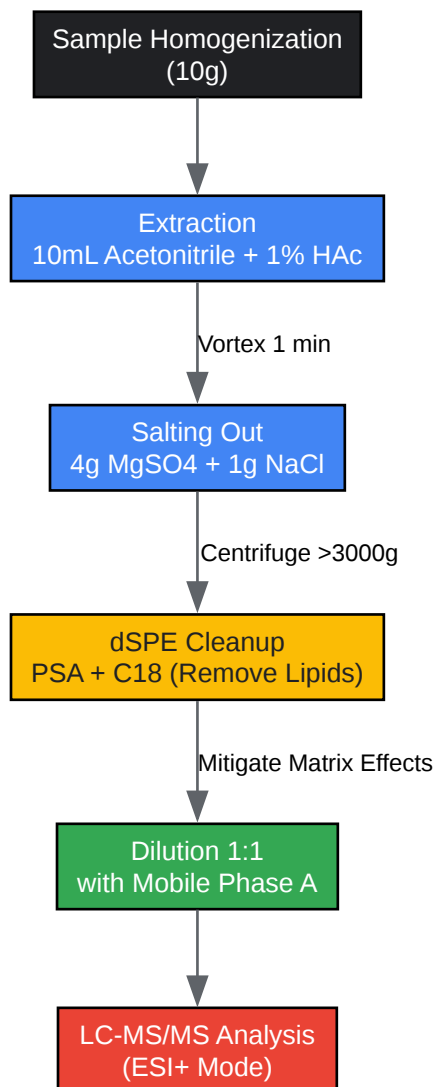

[Click to download full resolution via product page](#)

Figure 2: Optimized QuEChERS LC-MS/MS workflow for Fensulfothion.

Step-by-Step Methodology

- **Sample Preparation:** Weigh 10g of homogenized sample ($\pm 0.1g$) into a 50mL centrifuge tube.
- **Extraction:** Add 10mL Acetonitrile containing 1% Acetic Acid. (Acidification stabilizes the organophosphate).

- Partitioning: Add QuEChERS salts (4g MgSO₄, 1g NaCl). Shake vigorously for 1 minute. Centrifuge at 4000 rpm for 5 minutes.
- Cleanup (dSPE): Transfer 1mL of supernatant to a dSPE tube containing 150mg MgSO₄ and 25mg PSA (Primary Secondary Amine).
 - Caution: Do not use excessive PSA if analyzing acidic metabolites, though Fensulfothion is stable.
- Matrix Matching (Critical Step): Dilute the final extract 1:1 with the initial mobile phase (e.g., 5mM Ammonium Formate in Water) before injection. This aligns the solvent strength and reduces ion suppression.
- LC-MS/MS Parameters:
 - Column: C18 Reverse Phase (100mm x 2.1mm, 1.8μm).
 - Mobile Phase: (A) 5mM Ammonium Formate / (B) Methanol.
 - Transitions (MRM):
 - Quantifier: 309.0
281.0 m/z
 - Qualifier: 309.0
297.0 m/z

References

- U.S. Environmental Protection Agency. (2010). Method 8141B: Organophosphorus Compounds by Gas Chromatography.[1][2][3][5] SW-846 Update IV. [\[Link\]](#)
- European Union Reference Laboratories (EURL). (2008). QuEChERS: A Mini-Multiresidue Method for the Analysis of Pesticide Residues in Low-Fat Products. [\[Link\]](#)
- AOAC International. (2007).[6] Official Method 2007.01: Pesticide Residues in Foods by Acetonitrile Extraction and Partitioning with Magnesium Sulfate. [\[Link\]](#)

- Mastovska, K., & Lehotay, S. J. (2004). Evaluation of Common Organic Solvents for Gas Chromatographic Analysis and Stability of Multiclass Pesticide Residues. Journal of Chromatography A. [[Link](#)]

Need Custom Synthesis?

BenchChem offers custom synthesis for rare earth carbides and specific isotopic labeling.

Email: info@benchchem.com or [Request Quote Online](#).

Sources

- 1. [ysi.com](https://www.yisi.com) [[ysi.com](https://www.yisi.com)]
- 2. [analysis.rs](https://www.analysis.rs) [[analysis.rs](https://www.analysis.rs)]
- 3. [nemi.gov](https://www.nemi.gov) [[nemi.gov](https://www.nemi.gov)]
- 4. Simultaneous Analysis of Fenthion and Its Five Metabolites in Produce Using Ultra-High Performance Liquid Chromatography-Tandem Mass Spectrometry - PMC [[pmc.ncbi.nlm.nih.gov](https://pubmed.ncbi.nlm.nih.gov/16111111/)]
- 5. [epa.gov](https://www.epa.gov) [[epa.gov](https://www.epa.gov)]
- 6. [sigmaaldrich.com](https://www.sigmaaldrich.com) [[sigmaaldrich.com](https://www.sigmaaldrich.com)]
- To cite this document: BenchChem. [Inter-Laboratory Comparison Guide: Fensulfothion & Oxidative Metabolite Analysis]. BenchChem, [2026]. [Online PDF]. Available at: [<https://www.benchchem.com/product/b1157661/docs#inter-laboratory-comparison-guide-fensulfothion-oxidative-metabolite-analysis>]

Disclaimer & Data Validity:

The information provided in this document is for Research Use Only (RUO) and is strictly not intended for diagnostic or therapeutic procedures. While BenchChem strives to provide accurate protocols, we make no warranties, express or implied, regarding the fitness of this product for every specific experimental setup.

Technical Support: The protocols provided are for reference purposes. Unsure if this reagent suits your experiment?

Need Industrial/Bulk Grade? [Request Custom Synthesis Quote](#)

BenchChem

Our mission is to be the trusted global source of essential and advanced chemicals, empowering scientists and researchers to drive progress in science and industry.

Contact

Address: 3281 E Guasti Rd
Ontario, CA 91761, United States
Phone: (601) 213-4426
Email: info@benchchem.com

[Contact our Ph.D. Support Team for a compatibility check](#)