

Application Note: Optimizing ¹³C5-Deoxyadenosine Labeling Concentration for Primary Cells

Author: BenchChem Technical Support Team. **Date:** April 2026

Compound of Interest

Compound Name: 2'-Deoxyadenosine-
1',2',3',4',5'-¹³C5

Cat. No.: B1157560

[Get Quote](#)

Executive Summary

Quantifying deoxyribonucleoside triphosphate (dNTP) pools and their synthesis rates is critical for understanding DNA replication stress, immunometabolism, and nucleotide efficacy in primary cells.[1] Unlike immortalized cell lines, primary cells (e.g., PBMCs, T cells, primary fibroblasts) possess finite lifespans, distinct metabolic checkpoints, and high sensitivity to extracellular nucleosides.

This guide details the optimization of [1',2',3',4',5'-¹³C5]-2'-deoxyadenosine (¹³C5-dA) labeling. It addresses the critical technical paradox of this assay: Deoxyadenosine is inherently toxic to primary lymphocytes at high concentrations due to allosteric inhibition of Ribonucleotide Reductase (RNR). This protocol provides a self-validating framework to balance sufficient isotopic enrichment with physiological stability.

Mechanistic Background & The Toxicity Paradox[2]

To optimize labeling, one must understand the fate of the tracer. ¹³C5-dA tracks the purine salvage pathway.

- **Entry & Phosphorylation:** Extracellular dA enters via nucleoside transporters (ENTs) and is phosphorylated by Deoxycytidine Kinase (dCK) to dAMP, then to dADP and dATP.
- **The Trap (Toxicity):** In primary T cells, excessive intracellular dATP acts as a potent allosteric inhibitor of Ribonucleotide Reductase (RNR). RNR inhibition starves the cell of other dNTPs (dCTP, dGTP, dTTP), halting DNA synthesis and triggering apoptosis (the mechanism behind ADA-SCID).
- **The Competitor (ADA):** Adenosine Deaminase (ADA) converts dA to deoxyinosine (dI).
 - Note: Fetal Bovine Serum (FBS) contains high ADA activity. Without an ADA inhibitor, your ¹³C5-dA tracer will be rapidly converted to ¹³C5-dI, labeling the guanine pool (via Hypoxanthine) rather than the adenine pool specifically.

Diagram 1: The Deoxyadenosine Salvage & Toxicity Pathway

This diagram illustrates the bifurcating fate of the tracer and the feedback loop causing toxicity.

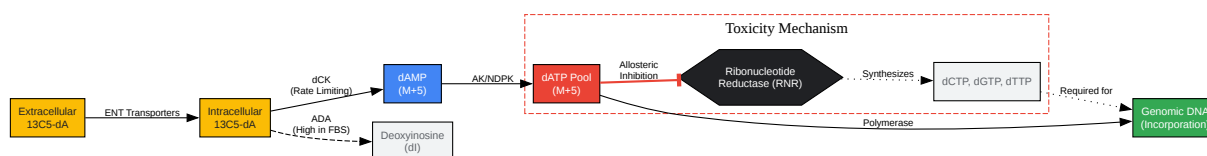

[Click to download full resolution via product page](#)

Caption: ¹³C5-dA Fate. High dATP pools inhibit RNR, depleting other dNTPs and causing cell death. ADA competes for the tracer.

Optimization Strategy: The "Range-Finding" Matrix

Do not proceed to a full flux experiment without determining the Maximum Tolerated Concentration (MTC) for your specific primary cell lot.

Experimental Design

Set up a 24-well plate with primary cells (e.g., 1×10^6 cells/mL). Test the following conditions for 24 hours.

Condition	13C5-dA Conc.[2] [3]	ADA Inhibitor (Pentostatin/EHNA)	Purpose
A (Control)	0 μ M	None	Baseline Viability
B (Low)	1 μ M	None	Low Flux, High ADA loss
C (Med)	10 μ M	None	Standard Start Point
D (High)	50 μ M	None	Overcoming ADA by mass action
E (Inhib)	1 μ M	+ 5 μ M Pentostatin	Pure Salvage (High Toxicity Risk)
F (Inhib)	5 μ M	+ 5 μ M Pentostatin	Pure Salvage (Max Flux)

Success Criteria:

- Viability: >85% relative to Control (Condition A).
- Enrichment: dATP M+5 isotopologue > 5% (detectable by LC-MS).

Recommendation:

- For pure salvage tracing: Use Condition E or F (Low dA + Inhibitor). This forces all label into dATP but requires strict viability monitoring.

- For general labeling (safer): Use Condition C or D (Higher dA, no inhibitor). You will lose signal to dI (guanine pool), but cells are less likely to die from dATP overload.

Detailed Protocol: ¹³C5-dA Labeling & Extraction

Phase 1: Reagent Preparation

- ¹³C5-Deoxyadenosine Stock (10 mM): Dissolve ¹³C5-dA (e.g., Cambridge Isotope Labs, Sigma) in sterile water or DMSO. Store at -20°C.
 - Critical Check: Ensure the label is on the Ribose ring ([1',2',3',4',5'-¹³C5]) if tracking nucleoside salvage vs. base recycling.
- Quenching Solution: 80% Methanol / 20% Water, pre-chilled to -80°C.

Phase 2: Cell Labeling

- Seeding: Seed primary cells at 1-2 x 10⁶ cells/mL in appropriate media (RPMI/DMEM + 10% Dialyzed FBS).
 - Note: Dialyzed FBS is preferred to remove endogenous unlabeled nucleosides that dilute the tracer.
- Equilibration: Allow cells to recover for 2-4 hours.
- Tracer Addition: Add ¹³C5-dA to the optimized concentration (e.g., 5 μM if using inhibitor, 20 μM if not).
- Incubation: Incubate for 4–24 hours.
 - Short Pulse (2-4h): For measuring rapid synthesis rates.
 - Long Pulse (24h): For measuring total pool turnover/accumulation.

Phase 3: Metabolite Extraction (Crucial Step)

dNTPs are labile. Speed is essential to prevent hydrolysis to dNDPs/dNMPs.

- Harvest: Transfer cell suspension to a 1.5 mL tube.

- Pellet: Centrifuge at 300 x g for 3 minutes at 4°C.
 - Tip: Do not spin faster; it stresses cells and alters metabolism.
- Wash: Aspirate media. Wash once rapidly with ice-cold PBS. Spin again (300 x g, 2 min).
- Quench/Lyse: Aspirate PBS completely. Immediately add 500 µL of -80°C 80% Methanol.
- Extract: Vortex vigorously for 30 seconds. Incubate on dry ice for 15 minutes.
- Clarify: Centrifuge at 15,000 x g for 15 minutes at 4°C to pellet protein/debris.
- Supernatant: Transfer supernatant to a fresh glass vial.
- Dry: Evaporate methanol under nitrogen stream (avoid heat) or speed-vac (cold mode).
- Reconstitute: Resuspend in 50-100 µL LC-MS grade water immediately prior to injection.

Diagram 2: Experimental Workflow

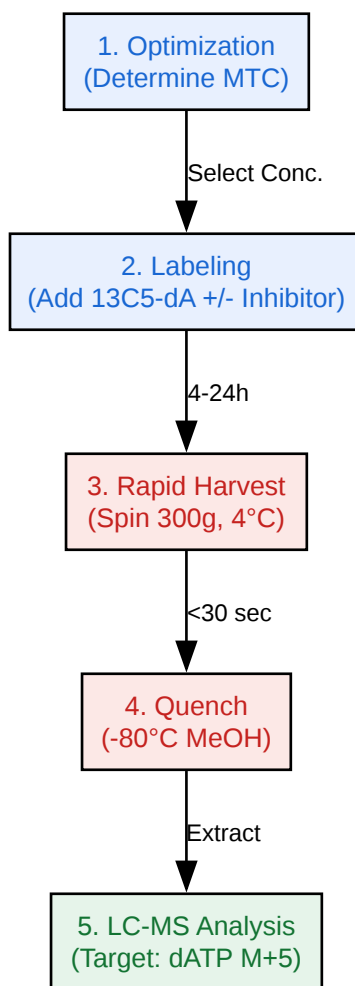

[Click to download full resolution via product page](#)

Caption: Workflow emphasizes the critical "Quench" step to preserve labile dNTPs.

LC-MS Analysis & Interpretation[5]

Instrument: Triple Quadrupole (QQQ) or Orbitrap. Chromatography: Anion Exchange (SAX) or Ion-Pairing Reverse Phase (IP-RP) is required to retain highly polar dNTPs. HILIC is an alternative but often shows poor peak shape for triphosphates.

Target Transitions (Example for QQQ):

- dATP (Unlabeled): Precursor 492.0 -> Product 136.0 (Adenine base).
- dATP (13C5-Ribose): Precursor 497.0 -> Product 136.0 (Base is unlabeled).

- Note: If the base were labeled, the product ion would shift. Since we use Ribose-13C5, the mass shift (+5) is on the parent but lost in the fragment if monitoring the base. Therefore, monitor the Parent->Parent transition or a fragment containing the ribose (e.g., 497 -> 197 phosphosugar) if possible, or rely on high-res MS1.

Calculation:

Troubleshooting & Validation

Issue	Probable Cause	Solution
High Cell Death	dATP accumulation inhibiting RNR.	Reduce 13C5-dA conc. or remove ADA inhibitor. Add 10 μ M Deoxycytidine (dC) to bypass RNR block (Rescue experiment).
Low Enrichment	High ADA activity in serum.	Use Dialyzed FBS. Add 5 μ M Pentostatin. Increase tracer conc.
No dATP Peak	Hydrolysis during extraction.	Ensure Methanol is -80°C. Work faster. Keep samples on ice.

References

- dATP Toxicity Mechanism
 - Kredich, N. M., & Martin, D. W. (1977). Role of deoxynucleoside triphosphate accumulation in adenosine deaminase deficiency.[4] *Cell*, 12(4), 931-938. [Link](#)
- Primary Cell Sensitivity
 - Godfrey, W. R., et al. (1984). Relative sensitivity of human T cell subsets to deoxyadenosine toxicity. *Clinical & Experimental Immunology*, 58(1), 136. [Link](#)
- LC-MS Method for dNTPs

- Kochanowski, K., et al. (2006). Functioning of a synthetic metabolic pathway in Escherichia coli. Proceedings of the National Academy of Sciences, 103(41), 15293. (Referencing dNTP extraction protocols). [Link](#)
- 13C-MFA Methodology
 - Antoniewicz, M. R. (2018).[5][6] A guide to 13C metabolic flux analysis for the cancer biologist. Experimental & Molecular Medicine, 50(4), 1-13. [Link](#)
- ADA in Serum
 - Spychala, J., et al. (1997). Exogenous and Endogenous Adenosine Inhibits Fetal Calf Serum–Induced Growth of Rat Cardiac Fibroblasts. Circulation Research, 80(4). [Link](#)

Need Custom Synthesis?

BenchChem offers custom synthesis for rare earth carbides and specific isotopic labeling.

Email: info@benchchem.com or [Request Quote Online](#).

Sources

- [1. Quantitative solid-phase assay to measure deoxynucleoside triphosphate pools - PMC \[pmc.ncbi.nlm.nih.gov\]](#)
- [2. 2'-Deoxyadenosine Monohydrate-13C5 | LGC Standards \[lgcstandards.com\]](#)
- [3. researchgate.net \[researchgate.net\]](#)
- [4. Deoxyadenosine toxicity in an adenosine deaminase-inhibited human CCRF-CEM T-lymphoblastoid cell line causes cell swelling - PubMed \[pubmed.ncbi.nlm.nih.gov\]](#)
- [5. A guide to 13C metabolic flux analysis for the cancer biologist - PMC \[pmc.ncbi.nlm.nih.gov\]](#)
- [6. d-nb.info \[d-nb.info\]](#)
- To cite this document: BenchChem. [Application Note: Optimizing 13C5-Deoxyadenosine Labeling Concentration for Primary Cells]. BenchChem, [2026]. [Online PDF]. Available at: [\[https://www.benchchem.com/product/b1157560/docs#application-note-optimizing-13c5-deoxyadenosine-labeling-concentration-for-primary-cells\]](https://www.benchchem.com/product/b1157560/docs#application-note-optimizing-13c5-deoxyadenosine-labeling-concentration-for-primary-cells)

Disclaimer & Data Validity:

The information provided in this document is for Research Use Only (RUO) and is strictly not intended for diagnostic or therapeutic procedures. While BenchChem strives to provide accurate protocols, we make no warranties, express or implied, regarding the fitness of this product for every specific experimental setup.

Technical Support: The protocols provided are for reference purposes. Unsure if this reagent suits your experiment?

Need Industrial/Bulk Grade? [Request Custom Synthesis Quote](#)

BenchChem

Our mission is to be the trusted global source of essential and advanced chemicals, empowering scientists and researchers to drive progress in science and industry.

Contact

Address: 3281 E Guasti Rd
Ontario, CA 91761, United States
Phone: (601) 213-4426
Email: info@benchchem.com

[Contact our Ph.D. Support Team for a compatibility check](#)