

Application Note: High-Throughput Shotgun Lipidomics of Glycerolipids

Author: BenchChem Technical Support Team. **Date:** May 2026

Compound of Interest

Compound Name: *1-Stearoyl-2-linoleoyl-sn-glycerol-d5*
Cat. No.: B1156222

[Get Quote](#)

Abstract

This guide details a robust workflow for the qualitative and quantitative analysis of Glycerolipids (GLs)—specifically Triacylglycerols (TAGs), Diacylglycerols (DAGs), and Monoacylglycerols (MAGs)—using Shotgun Lipidomics (Direct Infusion MS). Unlike LC-MS approaches, which suffer from retention time shifts and limited peak capacity for the vast complexity of TAG isomers, this protocol utilizes Multi-Dimensional Mass Spectrometry-Based Shotgun Lipidomics (MDMS-SL). We employ intrasource separation and class-specific Neutral Loss (NL) scanning to achieve high-throughput profiling suitable for drug discovery and metabolic disease research.

Principle of Operation: The "Shotgun" Advantage

Shotgun lipidomics relies on the direct infusion of lipid extracts into the ion source at a constant concentration. This steady-state condition allows for infinite acquisition time, enabling the user to perform multiple scan modes on the same sample without the time constraints of a chromatographic peak.

Intrasource Separation

A critical concept often misunderstood is that "shotgun" implies a lack of separation. In reality, we perform Intrasource Separation based on the electrical properties of lipid classes:

- **Ionization Environment:** By adjusting the pH and choosing specific modifiers (e.g., Ammonium Acetate vs. Lithium Hydroxide), we selectively ionize specific classes.
- **Glycerolipid Specificity:** Neutral GLs (TAGs/DAGs) are poorly ionizable. We force their ionization by forming adducts (typically) in positive ion mode, effectively separating them "electrically" from anionic lipids (like PS, PI) which are analyzed in negative mode.

Visualization of the Workflow

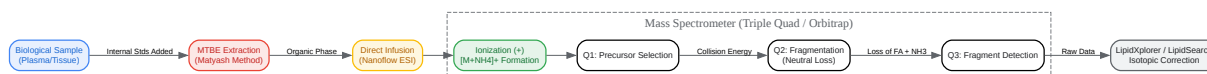

[Click to download full resolution via product page](#)

Figure 1: The MDMS-SL workflow emphasizing the transition from extraction to specific ionization and neutral loss scanning.

Sample Preparation Protocol

Objective: Extract neutral lipids with high efficiency while removing protein and salt contaminants. Method Choice: We utilize the Matyash Method (MTBE) over the traditional Bligh & Dyer.[1][2]

- Why? MTBE forms the upper phase, making recovery of neutral lipids easier and amenable to robotic automation (no risk of pipetting the protein pellet).

Reagents

- Methyl-tert-butyl ether (MTBE) (HPLC Grade)
- Methanol (HPLC Grade)
- Ammonium Acetate (solid)
- Internal Standard Cocktail (Critical):
 - TAG(15:0/15:0/15:0)-d5 (Deuterated Tripentadecanoin)
 - DAG(15:0/15:0)-d5
 - Note: Use non-endogenous odd-chain standards to avoid isobaric overlap with biological lipids.

Step-by-Step Procedure

- Lysis: Homogenize tissue (10 mg) or plasma (10 μ L) in 200 μ L Ice-Cold Methanol containing 0.01% BHT (antioxidant).
- Spiking: Add 10 μ L of Internal Standard Cocktail immediately. Crucial: Spiking before extraction corrects for extraction efficiency losses.
- Solvent Addition: Add 700 μ L of MTBE. Vortex for 1 hour at 4°C (shaker).
- Phase Separation: Add 200 μ L of MS-grade water to induce phase separation. Vortex for 10 min.
- Centrifugation: Spin at 1,000 x g for 10 min at 4°C.
- Collection: Collect the UPPER organic phase (MTBE) containing Glycerolipids.
 - Self-Validation Check: Ensure the interface is clear. If cloudy, re-centrifuge.
- Re-extraction (Optional): Add 300 μ L MTBE/MeOH/Water (10:3:2.5) to the lower phase to recover remaining lipids.[3] Combine upper phases.
- Drying: Evaporate solvent under a nitrogen stream or vacuum concentrator.

- Reconstitution: Resuspend in 200 μ L of Infusion Solvent: Chloroform/Methanol/Isopropanol (1:2:4 v/v/v) + 7.5 mM Ammonium Acetate.
 - Chemistry Note: Ammonium acetate is required to drive the formation of adducts.

Instrumentation & Acquisition Strategy

Platform: Triple Quadrupole (QqQ) or High-Res Hybrid (Orbitrap/Q-TOF). Ion Source: Nano-Electrospray (Nano-ESI) or ESI with low flow (5-10 μ L/min).

Mass Spectrometry Settings (Glycerolipid Focus)

Parameter	Setting	Rationale
Polarity	Positive (+)	TAGs/DAGs ionize preferentially as ammonium adducts.
Spray Voltage	4.0 - 5.0 kV	Higher voltage needed for stable spray of organic solvents.
Capillary Temp	250°C	Moderate heat prevents thermal degradation of labile lipids.
Collision Gas	Argon (1.5 mTorr)	Efficient fragmentation for Neutral Loss scans.
Adduct Target		Protonated TAGs are unstable and fragment in-source.

The "Building Block" Scanning Strategy

Glycerolipids are identified by the neutral loss of their fatty acyl chains.

- Mechanism:

- Scan Mode: Neutral Loss (NL) Scan.

Target List Construction: Instead of scanning every mass, we perform multiple NL scans corresponding to common fatty acids.

Target Fatty Acid	Neutral Loss Mass (u)	Explanation
Palmitic (16:0)	273.2	Loss of Palmitic Acid (256.2) + (17.0)
Oleic (18:1)	299.2	Loss of Oleic Acid (282.2) + (17.0)
Linoleic (18:2)	297.2	Loss of Linoleic Acid (280.2) + (17.0)
Stearic (18:0)	301.2	Loss of Stearic Acid (284.2) + (17.0)
Arachidonic (20:4)	321.2	Loss of Arachidonic Acid (304.2) + (17.0)

Note: The Mass Spectrometer scans Q1 and Q3 simultaneously with a fixed offset equal to the NL Mass.

TAG Identification Logic Diagram

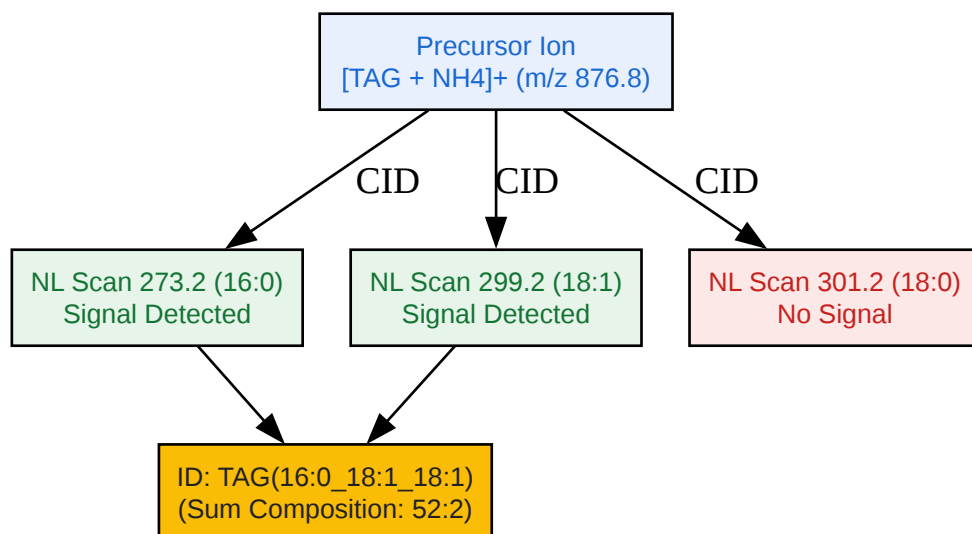

[Click to download full resolution via product page](#)

Figure 2: Logic flow for identifying a TAG species based on cross-referencing multiple Neutral Loss scans.

Data Analysis & Isotopic Correction

Shotgun lipidomics produces a "soup" of ions. Proper deconvolution is mandatory.

The Type I and Type II Isotope Problem

- Type I (Carbon Isotopes): The M+2 isotope of a TAG with double bonds overlaps with the monoisotopic peak of a TAG with double bonds.
 - Solution: Linear algebra deconvolution (built into software like LipidXplorer).
- Type II (Class Overlap): Less common in GLs but possible if PEs are present in positive mode (usually PEs are +H, TAGs are +NH₄).

Software Recommendation

We recommend LipidXplorer (Open Source) or LipidSearch (Thermo).

- Protocol for LipidXplorer:

- Import .mzML files.[4]
- Define MFQL (Molecular Fragmentation Query Language) scripts for "TAG neutral loss".
- Set tolerance: 0.2 Da (QqQ) or 5 ppm (Orbitrap).
- Quantification: Calculate Ratio = (Intensity_Analyte / Intensity_InternalStd) × Concentration_InternalStd.

Troubleshooting & Quality Control

Issue	Probable Cause	Corrective Action
Low Signal Intensity	Ion Suppression / Clogging	Check spray stability. Dilute sample 1:10. Ensure Ammonium Acetate is fresh.
No Ammonium Adducts	Wrong pH / Modifier	Verify 7.5mM Ammonium Acetate in infusion solvent. Avoid acidifying with Formic Acid for TAGs.
High Background	Plastic Contamination	NEVER use plasticware for chloroform/MTBE steps. Use glass vials/inserts only.
Inconsistent Quant	Hydrolysis	Keep samples on ice. Ensure enzymes are quenched immediately with MeOH.

References

- Han, X., & Gross, R. W. (2005). Shotgun lipidomics: Electrospray ionization mass spectrometric analysis and quantitation of cellular lipidomes directly from crude extracts of biological samples.[5][6] Mass Spectrometry Reviews.
 - [\[Link\]](#)
- Matyash, V., Liebisch, G., Kurzchalia, T. V., Shevchenko, A., & Schwudke, D. (2008). Lipid extraction by methyl-tert-butyl ether for high-throughput lipidomics.[1][3] Journal of Lipid

Research.[1][3]

- [\[Link\]](#)
- Herzog, R., et al. (2012). LipidXplorer: A Software for Consensual Cross-Platform Lipidomics.[4][7][8][9] PLOS ONE.
 - [\[Link\]](#)[4][8]
- Murphy, R. C., et al. (2007). Detection of the abundance of diacylglycerol and triacylglycerol molecular species in cells using neutral loss mass spectrometry.[10] Analytical Biochemistry.
 - [\[Link\]](#)

Need Custom Synthesis?

BenchChem offers custom synthesis for rare earth carbides and specific isotopic labeling.

Email: info@benchchem.com or [Request Quote Online](#).

Sources

- 1. publications.mpi-cbg.de [publications.mpi-cbg.de]
- 2. Lipid extraction by methyl-tert-butyl ether for high-throughput lipidomics - PMC [[pmc.ncbi.nlm.nih.gov](https://pubmed.ncbi.nlm.nih.gov/)]
- 3. lcms.cz [lcms.cz]
- 4. Release of LipidXplorer 1.2.8 - LIFS Tools web portal [lifs-tools.org]
- 5. researchgate.net [researchgate.net]
- 6. Mass spectrometry based shotgun lipidomics-a critical review from the technical point of view - PMC [[pmc.ncbi.nlm.nih.gov](https://pubmed.ncbi.nlm.nih.gov/)]
- 7. LipidXplorer: A Software for Consensual Cross-Platform Lipidomics | PLOS One [journals.plos.org]
- 8. zenodo.org [zenodo.org]
- 9. LipidXplorer - LIFS Tools web portal [lifs-tools.org]

- [10. An Overview of Lipidomic Analysis of Triglyceride Molecular Species in Biological Lipid Extracts - PMC \[pmc.ncbi.nlm.nih.gov\]](#)
- To cite this document: BenchChem. [Application Note: High-Throughput Shotgun Lipidomics of Glycerolipids]. BenchChem, [2026]. [Online PDF]. Available at: [\[https://www.benchchem.com/product/b1156222/docs#application-note-high-throughput-shotgun-lipidomics-of-glycerolipids\]](https://www.benchchem.com/product/b1156222/docs#application-note-high-throughput-shotgun-lipidomics-of-glycerolipids)

Disclaimer & Data Validity:

The information provided in this document is for Research Use Only (RUO) and is strictly not intended for diagnostic or therapeutic procedures. While BenchChem strives to provide accurate protocols, we make no warranties, express or implied, regarding the fitness of this product for every specific experimental setup.

Technical Support: The protocols provided are for reference purposes. Unsure if this reagent suits your experiment?

Need Industrial/Bulk Grade? [Request Custom Synthesis Quote](#)

BenchChem

Our mission is to be the trusted global source of essential and advanced chemicals, empowering scientists and researchers to drive progress in science and industry.

Contact

Address: 3281 E Guasti Rd
Ontario, CA 91761, United States
Phone: (601) 213-4426
Email: info@benchchem.com

[Contact our Ph.D. Support Team for a compatibility check](#)