

minimizing matrix effects in 13-cis-Fenretinide-d4 analysis

Author: BenchChem Technical Support Team. **Date:** May 2026

Compound of Interest

Compound Name: 13-cis-Fenretinide-d4

Cat. No.: B1154689

[Get Quote](#)

Technical Support Center: 13-cis-Fenretinide-d4 Analysis

Welcome to the technical support guide for minimizing matrix effects in bioanalytical methods involving Fenretinide and its stable isotope-labeled internal standard, **13-cis-Fenretinide-d4**. As Senior Application Scientists, we have designed this resource to provide researchers, scientists, and drug development professionals with practical, in-depth solutions to common challenges encountered during LC-MS/MS analysis. This guide moves beyond simple procedural lists to explain the underlying scientific principles, ensuring your methods are robust, reproducible, and reliable.

A Note on Nomenclature

In typical quantitative bioanalysis, Fenretinide (also known as 4-HPR) is the target analyte, and **13-cis-Fenretinide-d4** serves as its stable isotope-labeled internal standard (SIL-IS).^{[1][2]} The purpose of the SIL-IS is to mimic the analyte's behavior during sample preparation and analysis, thereby correcting for variability, including matrix effects.^{[3][4]} This guide is written from that perspective, addressing the challenges of ensuring that the analytical system

accurately quantifies Fenretinide by effectively utilizing **13-cis-Fenretinide-d4** to navigate the complexities of the biological matrix.

Frequently Asked Questions (FAQs)

Q1: What exactly is a 'matrix effect,' and why is it a critical issue in my Fenretinide assay?

Answer: A matrix effect is the alteration of an analyte's ionization efficiency by co-eluting, undetected components from the sample matrix (e.g., plasma, serum, tissue homogenate).[5][6] When these endogenous materials enter the mass spectrometer's ion source at the same time as your analyte (Fenretinide) and internal standard (**13-cis-Fenretinide-d4**), they can either suppress or enhance the signal.[7][8]

- **Ion Suppression:** The most common effect. Matrix components compete with the analyte for ionization, reducing the number of analyte ions that reach the detector. This leads to an underestimation of the analyte's true concentration.
- **Ion Enhancement:** Less common, but possible. Matrix components may improve the ionization efficiency of the analyte, leading to an overestimation of its concentration.

This is a critical issue because it directly impacts the accuracy and reproducibility of your quantitative results.[9] An uncharacterized or poorly controlled matrix effect can lead to erroneous pharmacokinetic data and flawed conclusions in a drug development program. According to regulatory guidelines from the FDA and ICH, assessing and minimizing matrix effects is a mandatory part of bioanalytical method validation.[10][11]

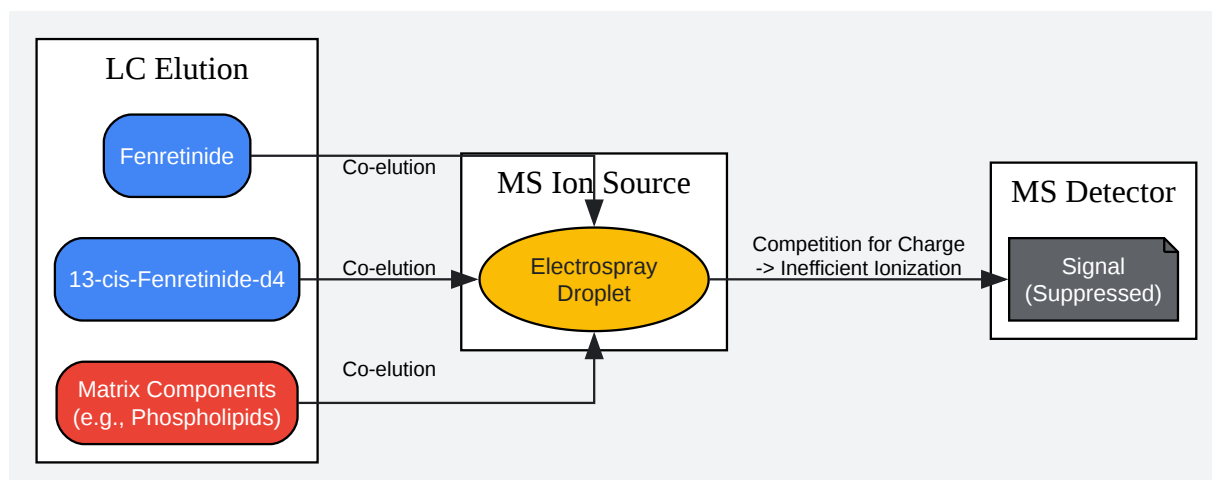

[Click to download full resolution via product page](#)

Caption: The mechanism of ion suppression in the MS source.

Q2: My assay is showing significant ion suppression. What are the most likely culprits in my plasma samples?

Answer: In plasma or serum samples, the most common causes of matrix effects are phospholipids.[12] These are abundant endogenous molecules (~1 mg/mL) from cell membranes that are often not fully removed by simple sample preparation techniques like protein precipitation (PPT).[13]

Causality: Phospholipids have a polar head group and a non-polar tail. During reversed-phase chromatography, they tend to be poorly retained and can elute as broad peaks across a wide portion of the gradient, often overlapping with analytes of interest.[13] In the ion source, they are readily ionized and can severely suppress the signal of co-eluting compounds like Fenretinide. Other potential sources of interference include salts, proteins, and metabolites.

Q3: How does using 13-cis-Fenretinide-d4 as an internal standard help combat matrix effects?

Answer: The use of a stable isotope-labeled internal standard (SIL-IS) is the most recognized and effective method for correcting matrix effects.[3][14] The underlying principle is that a SIL-IS is chemically and physically almost identical to the analyte.[1][15]

The Self-Validating System:

- Co-elution: **13-cis-Fenretinide-d4** is designed to have the same chromatographic retention time as Fenretinide.
- Identical Behavior: It experiences the exact same extraction recovery losses and, crucially, the same degree of ion suppression or enhancement in the MS source.[3]
- Correction: The quantification is based on the ratio of the analyte peak area to the IS peak area. Since both are affected proportionally by the matrix, the ratio remains constant and reflects the true concentration of the analyte.

If the matrix suppresses both the Fenretinide and the **13-cis-Fenretinide-d4** signal by 30%, the ratio of their peak areas remains unchanged, providing an accurate result. This is why it is considered the gold standard.[16]

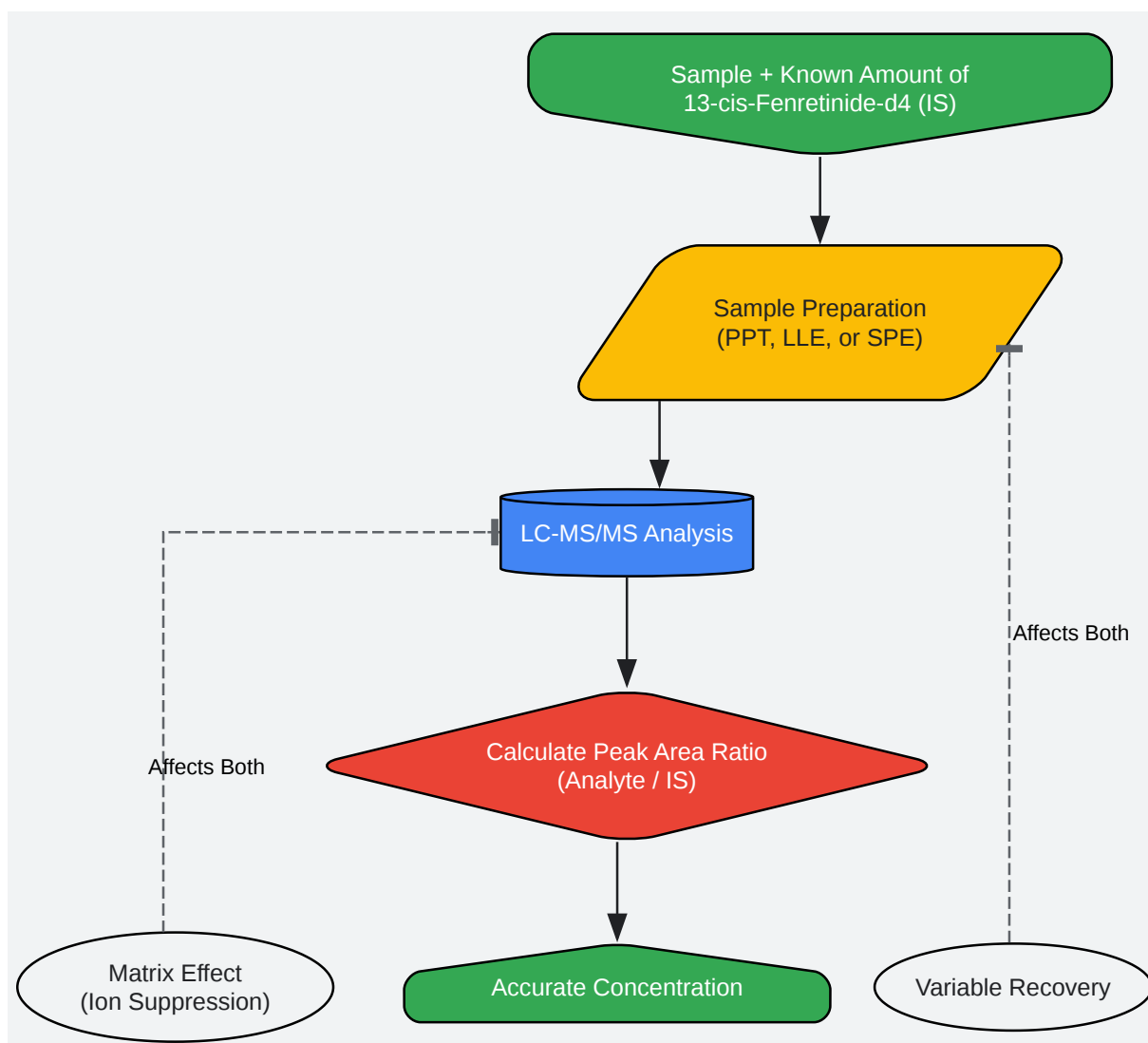

[Click to download full resolution via product page](#)

Caption: How a SIL-IS corrects for process variability.

Troubleshooting Guide

This section addresses specific problems you may encounter.

Problem	Probable Cause(s)	Recommended Solution(s)
<p>Poor precision & accuracy in QC samples.</p>	<p>Significant and variable matrix effects between different lots of blank matrix. The SIL-IS may not be perfectly co-eluting with the analyte.</p>	<p>1. Improve Sample Cleanup: The primary goal is to remove interferences before they enter the LC-MS system. Move from a simple Protein Precipitation (PPT) to a more selective technique like Liquid-Liquid Extraction (LLE) or Solid-Phase Extraction (SPE). Phospholipid removal (PLR) specific plates or cartridges are highly effective.[17][18][19] 2. Optimize Chromatography: Modify your LC gradient to better separate Fenretinide from the "matrix band," especially early-eluting phospholipids.[12][20] 3. Dilute the Sample: If sensitivity allows, diluting the sample can reduce the concentration of matrix components entering the system.[21]</p>
<p>Internal standard (IS) response is erratic or very low.</p>	<p>The IS itself is experiencing significant ion suppression. The IS may have degraded during sample storage or processing.</p>	<p>1. Evaluate Sample Prep: As above, enhance the cleanup procedure. Techniques like HybridSPE®-PPT are designed specifically to remove phospholipids that suppress ionization.[13] 2. Check Analyte Stability: Retinoids can be sensitive to light and temperature.[22] Ensure samples are handled under yellow light and kept</p>

cold. Confirm the stability of 13-cis-Fenretinide-d4 under your specific extraction and storage conditions as part of your method validation.[23]

Matrix effect is confirmed, but I cannot change the sample prep method.

The current method is validated and used in a high-throughput environment.

1. Chromatographic Refinement: Even small changes can help. Increase the organic content of the mobile phase at the start of the gradient to quickly elute phospholipids before your analyte. A divert valve can also be used to send the initial, "dirty" part of the eluent to waste instead of the MS source. 2. Matrix-Matched Calibrators: If you cannot eliminate the effect, you must compensate for it. Prepare your calibration standards and QCs in the same blank biological matrix as your unknown samples.[4][5] This ensures that the standards experience the same matrix effect as the samples, allowing for accurate quantification, assuming the effect is consistent across different sources of the matrix.

Experimental Protocols & Methodologies

Protocol 1: Phospholipid Removal using HybridSPE®-PPT

This protocol combines the simplicity of protein precipitation with the selectivity of solid-phase extraction to effectively remove both proteins and phospholipids.[13]

Objective: To achieve a cleaner extract compared to standard protein precipitation, thereby minimizing matrix effects.

Materials:

- Plasma sample containing Fenretinide and **13-cis-Fenretinide-d4**.
- HybridSPE®-PPT 96-well plate or cartridges.
- Acetonitrile with 1% formic acid (Precipitation Agent).
- 96-well collection plate.
- Vacuum manifold.

Procedure:

- Spike IS: Add a known concentration of **13-cis-Fenretinide-d4** working solution to your plasma sample. Vortex briefly.
- Sample Loading: Load 100 µL of the plasma sample into the wells of the HybridSPE®-PPT plate.
- Precipitation: Add 300 µL of the precipitation agent (1% formic acid in acetonitrile) to each well.
- Mixing: Mix thoroughly. A 96-well plate shaker or repeated pipetting is effective. Allow to sit for 4-5 minutes to ensure complete protein precipitation.
- Extraction: Place the plate on a vacuum manifold and apply vacuum (~10 in. Hg). The filtrate, now depleted of proteins and phospholipids, will be collected in the collection plate below.
- Evaporation & Reconstitution: Evaporate the collected filtrate to dryness under a stream of nitrogen at approximately 40°C.

- Final Sample: Reconstitute the dried extract in a suitable mobile phase (e.g., 100 μ L of 50:50 acetonitrile:water) for LC-MS/MS injection.

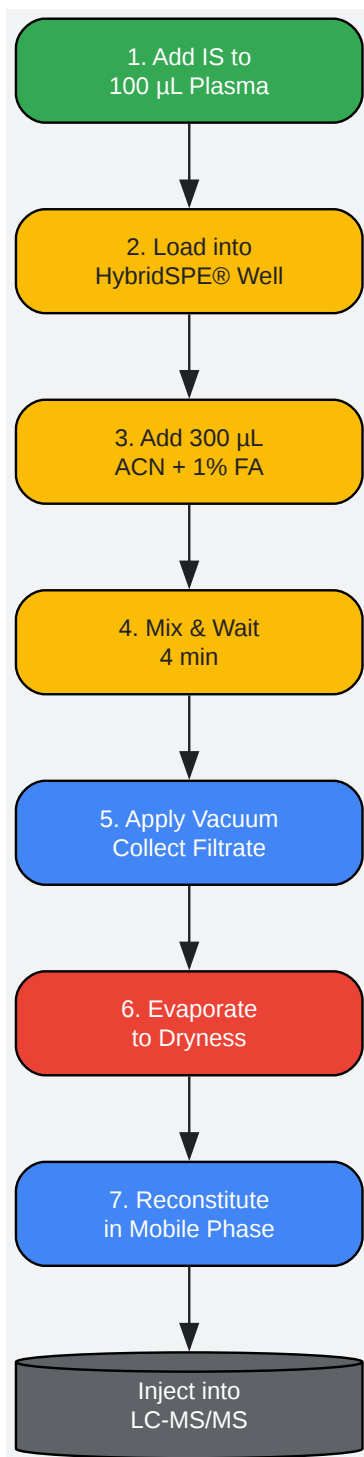

[Click to download full resolution via product page](#)

Caption: Workflow for HybridSPE®-PPT sample preparation.

Comparison of Sample Preparation Techniques

The choice of sample preparation is the most critical factor in mitigating matrix effects. Here is a comparison of common techniques for Fenretinide analysis in plasma.

Technique	Principle	Phospholipid Removal	Recovery & Reproducibility	Throughput
Protein Precipitation (PPT)	Proteins are denatured and precipitated with an organic solvent (e.g., acetonitrile).[24] [25]	Poor. Phospholipids remain soluble in the supernatant.	High recovery but poor reproducibility due to significant matrix effects. [26]	High
Liquid-Liquid Extraction (LLE)	Partitioning of the analyte between two immiscible liquid phases (e.g., hexane extraction).[25] [27]	Good. Phospholipids have different solubility profiles.	Can be highly variable and analyte-dependent. May have lower recovery for more polar metabolites.[26]	Medium
Solid-Phase Extraction (SPE)	Analyte is retained on a solid sorbent while interferences are washed away. [17]	Excellent. Specific sorbents (e.g., mixed-mode) can be chosen to retain the analyte and wash away phospholipids. [26]	High recovery and excellent reproducibility.	Low to Medium
HybridSPE®-PPT	Combines protein precipitation with phospholipid filtration in one device.[13]	Excellent. Zirconia-coated particles specifically bind and remove phospholipids.	High recovery and excellent reproducibility due to effective interference removal.	High

References

- Strategies for the Detection and Elimination of Matrix Effects in Quantitative LC–MS Analysis. (n.d.). Chromatography Online. Retrieved February 8, 2026, from [\[Link\]](#)
- Stahnke, H., et al. (2021). Compensate for or Minimize Matrix Effects? Strategies for Overcoming Matrix Effects in Liquid Chromatography-Mass Spectrometry Technique: A Tutorial Review. MDPI. [\[Link\]](#)
- Shuo-Jun, O. (2024). Matrix Effects in Mass Spectrometry Analysis: Causes and Solutions. Welch Materials, Inc. [\[Link\]](#)
- Jafari, M., et al. (2021). Overview, consequences, and strategies for overcoming matrix effects in LC-MS analysis: a critical review. PubMed. [\[Link\]](#)
- Zhu, Y., et al. (2016). Analysis of Fenretinide and its metabolites in human plasma by liquid chromatography-tandem mass spectrometry and its application to clinical pharmacokinetics. National Institutes of Health (NIH). [\[Link\]](#)
- Minimizing matrix effects while preserving throughput in LC-MS/MS bioanalysis. (n.d.). APST. Retrieved February 8, 2026, from [\[Link\]](#)
- Two distinct sample prep approaches to overcome matrix effect in LC/MS of serum or plasma samples. (n.d.). Bioanalysis Zone. [\[Link\]](#)
- Hewavitharana, A. K. (2010). Strategies for the Detection and Elimination of Matrix Effects in Quantitative LC–MS Analysis. LCGC North America. [\[Link\]](#)
- Chambers, E., et al. (2007). Systematic and comprehensive strategy for reducing matrix effects in LC/MS/MS analyses. PubMed. [\[Link\]](#)
- Matteo, C., et al. (2024). Validated LC-MS/MS Assay for the Quantitative Determination of Fenretinide in Plasma and Tumor and Its Application in a Pharmacokinetic Study in Mice of a Novel Oral Nanoformulation of Fenretinide. MDPI. [\[Link\]](#)
- Identification of retinoic acid (tretinoin) in cosmetic products by tlc and hplc. (n.d.). HAS. Retrieved February 8, 2026, from [\[Link\]](#)

- Li, W., et al. (2012). Matrix effects break the LC behavior rule for analytes in LC-MS/MS analysis of biological samples. National Institutes of Health (NIH). [\[Link\]](#)
- All You Need To Know About Phospholipid Removal (PLR). (n.d.). Element Lab Solutions. [\[Link\]](#)
- The Use of Stable-Isotope-Labeled (SIL) Internal Standards to Compensate for Matrix Effects: Key Considerations. (n.d.). Waters Corporation. [\[Link\]](#)
- Designing Stable Isotope Labeled Internal Standards. (2022). Acanthus Research. [\[Link\]](#)
- Are You Using The Internal Standard Method In A Right Way? (2025). WelchLab. [\[Link\]](#)
- Analytical methods for determining retinol in skincare formulations: A comprehensive review. (2025). Journal of Phytonanotechnology and Pharmaceutical Sciences (JPPS). [\[Link\]](#)
- The Role of Internal Standards In Mass Spectrometry. (n.d.). SCION Instruments. [\[Link\]](#)
- An Improved Method for Eliminating Ion Suppression and Other Phospholipid-Induced Interferences in Bioanalytical Samples. (n.d.). LCGC International. [\[Link\]](#)
- Barua, A. B. (2025). Properties of Retinoids: Structure, Handling, and Preparation. ResearchGate. [\[Link\]](#)
- Hewavitharana, A. K., et al. (2018). Standard addition with internal standardisation as an alternative to using stable isotope labelled internal standards to correct for matrix effects- Comparison and validation using liquid chromatography-tandem mass spectrometric assay of vitamin D. PubMed. [\[Link\]](#)
- Bioanalytical Method Validation for Biomarkers Guidance. (n.d.). HHS.gov. [\[Link\]](#)
- Matrix Effects on Quantitation in Liquid Chromatography: Sources and Solutions. (2025). Restek. [\[Link\]](#)
- Matteo, C., et al. (2025). Validated LC-MS/MS Assay for the Quantitative Determination of Fenretinide in Plasma and Tumor and Its Application in a Pharmacokinetic Study in Mice of a Novel Oral Nanoformulation of Fenretinide. ResearchGate. [\[Link\]](#)

- Stokvis, E., et al. (2002). Stable isotopically labeled internal standards in quantitative bioanalysis using liquid chromatography/mass spectrometry: necessity or not? PubMed. [\[Link\]](#)
- What are Matrix Effect in Liquid Chromatography Mass Spectrometry? (n.d.). NorthEast BioLab. [\[Link\]](#)
- Bioanalytical method validation and study sample analysis m10. (2022). ICH. [\[Link\]](#)
- Improve LC/MS/MS and Remove Phospholipids with Phree. (2013). YouTube. [\[Link\]](#)
- Kane, M. A., et al. (2010). A sensitive and specific method for measurement of multiple retinoids in human serum with UHPLC-MS/MS. National Institutes of Health (NIH). [\[Link\]](#)
- Choose an Internal Standard to Compensate Matrix Effects in LC-MS/MS Method. (2023). RPubS. [\[Link\]](#)
- How Sample Prep for Phospholipid Removal Works. (n.d.). Lab Manager. [\[Link\]](#)
- Accounting for the matrix effect. (2024). Reddit. [\[Link\]](#)
- Matteo, C., et al. (2024). Validated LC-MS/MS Assay for the Quantitative Determination of Fenretinide in Plasma and Tumor and Its Application in a Pharmacokinetic Study in Mice of a Novel Oral Nanoformulation of Fenretinide. PubMed. [\[Link\]](#)
- Development and Validation of Analysis Methods for Retinoids, Arbutin, Nicotinamide in HPLC Cosmetics. (2024). Formosa Publisher. [\[Link\]](#)
- Matrix effects: Causes and solutions. (n.d.). ResearchGate. [\[Link\]](#)
- FDA Guidance for Industry on Bioanalytical Method Validation (BMV) for Biomarkers. (n.d.). Contract Pharma. [\[Link\]](#)
- USE OF STABLE ISOTOPE INTERNAL STANDARDS FOR TRACE ORGANIC ANALYSIS. (n.d.). NSI. Retrieved February 8, 2026, from [\[Link\]](#)
- Bioanalytical Method Validation. (n.d.). FDA. Retrieved February 8, 2026, from [\[Link\]](#)

- FDA Adopts ICH Final Guidance On Bioanalytical Method Validation. (2023). Outsourced Pharma. [[Link](#)]

Need Custom Synthesis?

BenchChem offers custom synthesis for rare earth carbides and specific isotopic labeling.

Email: info@benchchem.com or [Request Quote Online](#).

Sources

- 1. Designing Stable Isotope Labeled Internal Standards - Acanthus Research [acanthusresearch.com]
- 2. The Role of Internal Standards In Mass Spectrometry | SCION Instruments [scioninstruments.com]
- 3. waters.com [waters.com]
- 4. reddit.com [reddit.com]
- 5. welch-us.com [welch-us.com]
- 6. Matrix effects break the LC behavior rule for analytes in LC-MS/MS analysis of biological samples - PMC [pmc.ncbi.nlm.nih.gov]
- 7. chromatographyonline.com [chromatographyonline.com]
- 8. nebiolab.com [nebiolab.com]
- 9. Overview, consequences, and strategies for overcoming matrix effects in LC-MS analysis: a critical review - PubMed [pubmed.ncbi.nlm.nih.gov]
- 10. database.ich.org [database.ich.org]
- 11. FDA Adopts ICH Final Guidance On Bioanalytical Method Validation [outsourcedpharma.com]
- 12. semanticscholar.org [semanticscholar.org]
- 13. How Sample Prep for Phospholipid Removal Works | Lab Manager [labmanager.com]
- 14. chromatographyonline.com [chromatographyonline.com]
- 15. s3-eu-west-1.amazonaws.com [s3-eu-west-1.amazonaws.com]
- 16. Standard addition with internal standardisation as an alternative to using stable isotope labelled internal standards to correct for matrix effects-Comparison and validation using

[liquid chromatography-tandem mass spectrometric assay of vitamin D - PubMed](#)
[pubmed.ncbi.nlm.nih.gov]

- [17. bioanalysis-zone.com](#) [bioanalysis-zone.com]
- [18. elementlabsolutions.com](#) [elementlabsolutions.com]
- [19. m.youtube.com](#) [m.youtube.com]
- [20. chromatographyonline.com](#) [chromatographyonline.com]
- [21. mdpi.com](#) [mdpi.com]
- [22. researchgate.net](#) [researchgate.net]
- [23. hhs.gov](#) [hhs.gov]
- [24. Analysis of Fenretinide and its metabolites in human plasma by liquid chromatography-tandem mass spectrometry and its application to clinical pharmacokinetics - PMC](#)
[pmc.ncbi.nlm.nih.gov]
- [25. A sensitive and specific method for measurement of multiple retinoids in human serum with UHPLC-MS/MS - PMC](#) [pmc.ncbi.nlm.nih.gov]
- [26. Systematic and comprehensive strategy for reducing matrix effects in LC/MS/MS analyses - PubMed](#) [pubmed.ncbi.nlm.nih.gov]
- [27. jpps.ukaazpublications.com](#) [jpps.ukaazpublications.com]
- To cite this document: BenchChem. [minimizing matrix effects in 13-cis-Fenretinide-d4 analysis]. BenchChem, [2026]. [Online PDF]. Available at: [https://www.benchchem.com/product/b1154689/docs#minimizing-matrix-effects-in-13-cis-fenretinide-d4-analysis]

Disclaimer & Data Validity:

The information provided in this document is for Research Use Only (RUO) and is strictly not intended for diagnostic or therapeutic procedures. While BenchChem strives to provide accurate protocols, we make no warranties, express or implied, regarding the fitness of this product for every specific experimental setup.

Technical Support: The protocols provided are for reference purposes. Unsure if this reagent suits your experiment?

Need Industrial/Bulk Grade? [Request Custom Synthesis Quote](#)

BenchChem

Our mission is to be the trusted global source of essential and advanced chemicals, empowering scientists and researchers to drive progress in science and industry.

Contact

Address: 3281 E Guasti Rd

Ontario, CA 91761, United States

Phone: (601) 213-4426

Email: info@benchchem.com

[Contact our Ph.D. Support Team for a compatibility check](#)