

Application Notes and Protocols for **Ebio1**, a KCNQ2 Channel Activator

Author: BenchChem Technical Support Team. **Date:** April 2026

Compound of Interest

Compound Name: *Ebio1*
Cat. No.: *B11531682*

[Get Quote](#)

For Researchers, Scientists, and Drug Development Professionals

Introduction

Ebio1 is a potent and subtype-selective small-molecule activator of the voltage-gated potassium channel KCNQ2 (Kv7.2).^{[1][2][3]} KCNQ2 channels are crucial for neuronal excitability, and their dysfunction is linked to neurological disorders such as epilepsy.^{[4][5]}

Ebio1 represents a valuable pharmacological tool for studying KCNQ2 channel function and a potential scaffold for the development of novel therapeutics.^{[1][6]}

Unlike traditional KCNQ activators that primarily modulate the voltage-dependent gating of the channel, **Ebio1** employs a unique "twist-to-open" mechanism.^{[1][6]} It directly engages the channel gate, leading to an extended open state with increased conductance.^{[1][7][8]} This document provides detailed application notes and protocols for utilizing **Ebio1** to activate KCNQ2 channels, with a focus on determining its optimal concentration.

Quantitative Data Summary

The following table summarizes the key quantitative parameters of **Ebio1**'s effect on KCNQ2 channels as reported in the literature.

Parameter	Value	Channel Type	Experimental System	Reference
EC50	247.3 nM	KCNQ2	Not specified	[2]
EC50	247 nM	KCNQ2	Not specified	[9]
Effect at 10 μ M	34.32 \pm 2.00 mV leftward shift in V1/2 of activation	KCNQ2	Not specified	[2]

Note: The half-maximal activation voltage (V1/2) was shifted from -16.65 mV to -50.97 mV in the presence of 10 μ M **Ebio1**. [2]

Mechanism of Action

Ebio1 binds to a pocket in the pore domain of the KCNQ2 channel. [1] This binding induces a conformational change in the S6 helices, causing them to twist and open the channel gate. [1] [6] This mechanism is distinct from other activators and results in both an increased open probability and a larger single-channel conductance. [9][10]

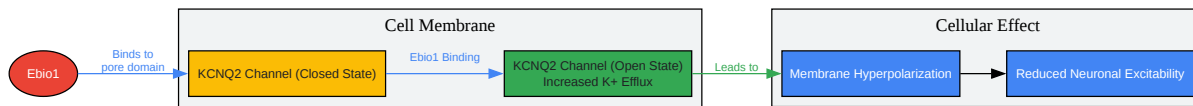

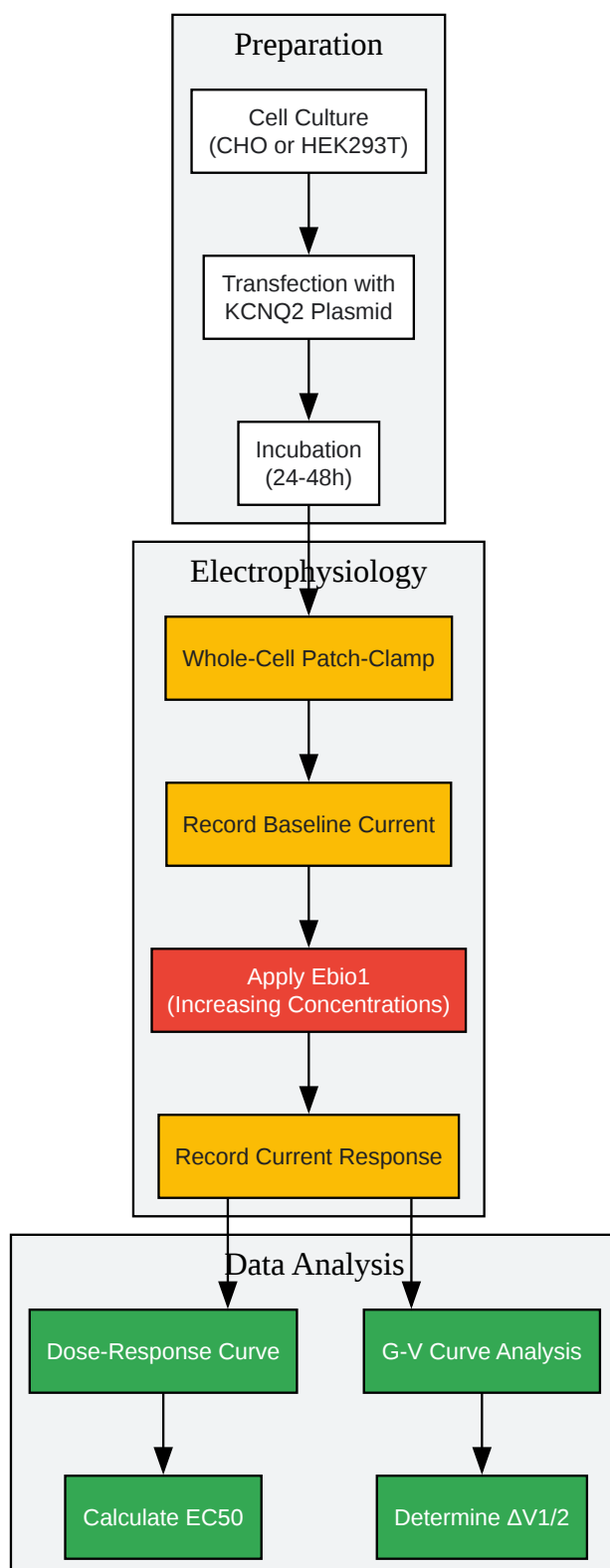

[Click to download full resolution via product page](#)

Need Custom Synthesis?

BenchChem offers custom synthesis for rare earth carbides and specific isotopic labeling.

Email: info@benchchem.com or [Request Quote Online](#).

References

- [1. A small-molecule activation mechanism that directly opens the KCNQ2 channel - PubMed \[pubmed.ncbi.nlm.nih.gov\]](#)
- [2. KCNQ2 activator Ebio1 | KCNQ2 activator | Probechem Biochemicals \[probechem.com\]](#)
- [3. consensus.app \[consensus.app\]](#)
- [4. Molecular basis for ligand activation of the human KCNQ2 channel - PMC \[pmc.ncbi.nlm.nih.gov\]](#)
- [5. Potassium current inactivation as a novel pathomechanism for KCNQ2 developmental and epileptic encephalopathy - PMC \[pmc.ncbi.nlm.nih.gov\]](#)
- [6. researchgate.net \[researchgate.net\]](#)
- [7. adooq.com \[adooq.com\]](#)
- [8. medchemexpress.com \[medchemexpress.com\]](#)
- [9. Ebio1 Supplier | CAS 339287-36-4 | Tocris Bioscience \[tocris.com\]](#)
- [10. A small-molecule activation mechanism that directly opens the KCNQ2 channel: Abstract, Citation \(BibTeX\) & Reference | Bohrium \[bohrium.com\]](#)
- To cite this document: BenchChem. [Application Notes and Protocols for Ebio1, a KCNQ2 Channel Activator]. BenchChem, [2026]. [Online PDF]. Available at: [\[https://www.benchchem.com/product/b11531682/docs#application-notes-and-protocols-for-ebio1-a-kcnq2-channel-activator\]](https://www.benchchem.com/product/b11531682/docs#application-notes-and-protocols-for-ebio1-a-kcnq2-channel-activator)

Disclaimer & Data Validity:

The information provided in this document is for Research Use Only (RUO) and is strictly not intended for diagnostic or therapeutic procedures. While BenchChem strives to provide accurate protocols, we make no warranties, express or implied, regarding the fitness of this product for every specific experimental setup.

Technical Support: The protocols provided are for reference purposes. Unsure if this reagent suits your experiment?

Need Industrial/Bulk Grade? [Request Custom Synthesis Quote](#)

BenchChem

Our mission is to be the trusted global source of essential and advanced chemicals, empowering scientists and researchers to drive progress in science and industry.

Contact

Address: 3281 E Guasti Rd
Ontario, CA 91761, United States
Phone: (601) 213-4426
Email: info@benchchem.com

[Contact our Ph.D. Support Team for a compatibility check](#)