

# Application Note: Advanced Methodologies for the Quantification of Intracellular c-di-AMP

**Author:** BenchChem Technical Support Team. **Date:** April 2026

## Compound of Interest

Compound Name: *c-Di-AMP sodium salt*

Cat. No.: *B1150292*

[Get Quote](#)

Target Audience: Analytical Chemists, Microbiologists, and Drug Development Professionals

Document Type: Technical Guide & Validated Protocols

## Executive Summary

Cyclic di-adenosine monophosphate (c-di-AMP) is an essential nucleotide second messenger predominantly found in Gram-positive bacteria (e.g., *Staphylococcus aureus*, *Bacillus subtilis*, *Listeria monocytogenes*). It is a master regulator of potassium ion homeostasis, cell wall metabolism, and DNA repair [1](#). In the context of host-pathogen interactions, c-di-AMP acts as a potent agonist for the mammalian STING (Stimulator of Interferon Genes) pathway, making it a molecule of high interest in vaccine adjuvant development and antimicrobial drug discovery [2](#).

Measuring intracellular c-di-AMP presents unique analytical challenges due to its low physiological concentration (0.1–2  $\mu\text{M}$ ) and its rapid degradation by endogenous phosphodiesterases (PDEs) during sample extraction [3](#). This guide details the causality behind experimental choices and provides self-validating protocols for the two leading quantification methods: Isotope-Dilution LC-MS/MS and In Vivo Fluorescent Biosensors.

## Biological Context & Analytical Challenges

c-di-AMP is synthesized from two ATP molecules by diadenylate cyclases (DACs, such as DisA and CdaA) and hydrolyzed into pApA or AMP by specific PDEs (such as GdpP and PgpH) [2](#).

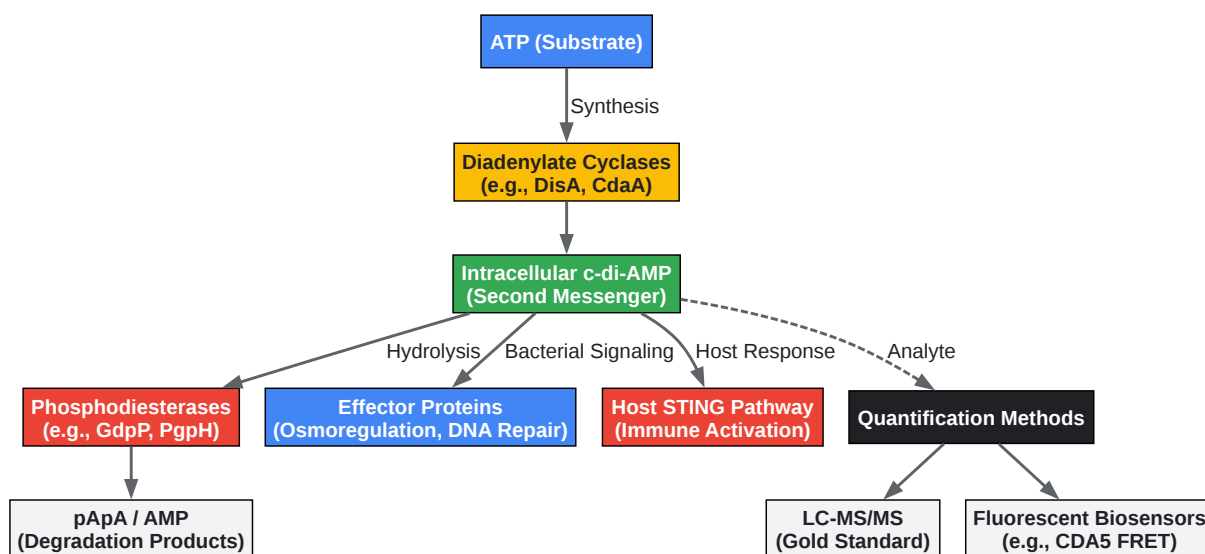

[Click to download full resolution via product page](#)

Fig 1: c-di-AMP metabolic pathway, downstream signaling, and analytical quantification targets.

## The Three Pillars of Measurement Failure

- **Enzymatic Artifacts:** If cellular metabolism is not instantly quenched, stress-induced PDEs will artificially deplete c-di-AMP pools during the minutes it takes to harvest cells [1](#).
- **Matrix Suppression:** Bacterial lysates contain high concentrations of salts, lipids, and peptides that suppress the ionization of c-di-AMP in the mass spectrometer source.

- Population Averaging: Traditional bulk extraction masks the high degree of single-cell heterogeneity present in bacterial populations responding to osmotic stress [3](#).

## Quantitative Comparison of Measurement Modalities

To select the appropriate assay, researchers must balance the need for absolute quantification against the need for spatial-temporal resolution.

| Methodology                 | Limit of Detection (LOD) | Dynamic Range           | Spatial Resolution | Primary Application                               |
|-----------------------------|--------------------------|-------------------------|--------------------|---|
| Isotope-Dilution LC-MS/MS   | ~1-5 nM                  | 5 nM - 10 $\mu$ M       | Bulk Population    | Absolute quantification of steady-state levels.   |
| Competitive ELISA           | ~10-50 nM                | 50 nM - 5 $\mu$ M       | Bulk Population    | High-throughput screening (in vitro assays).      |
| FRET Biosensor (e.g., CDA5) | ~0.1 $\mu$ M             | 0.1 $\mu$ M - 2 $\mu$ M | Single-Cell        | Real-time intracellular dynamics & heterogeneity. |
| RNA Riboswitch (bsuO P6-4)  | ~50 nM                   | 50 nM - 5 $\mu$ M       | Single-Cell        | In vivo tracking in pathogenic clinical strains.  |

## Protocol I: Isotope-Dilution LC-MS/MS (The Gold Standard)

This protocol utilizes an internal standard to create a self-validating extraction system, ensuring that any physical loss or ion suppression is mathematically normalized [3](#).

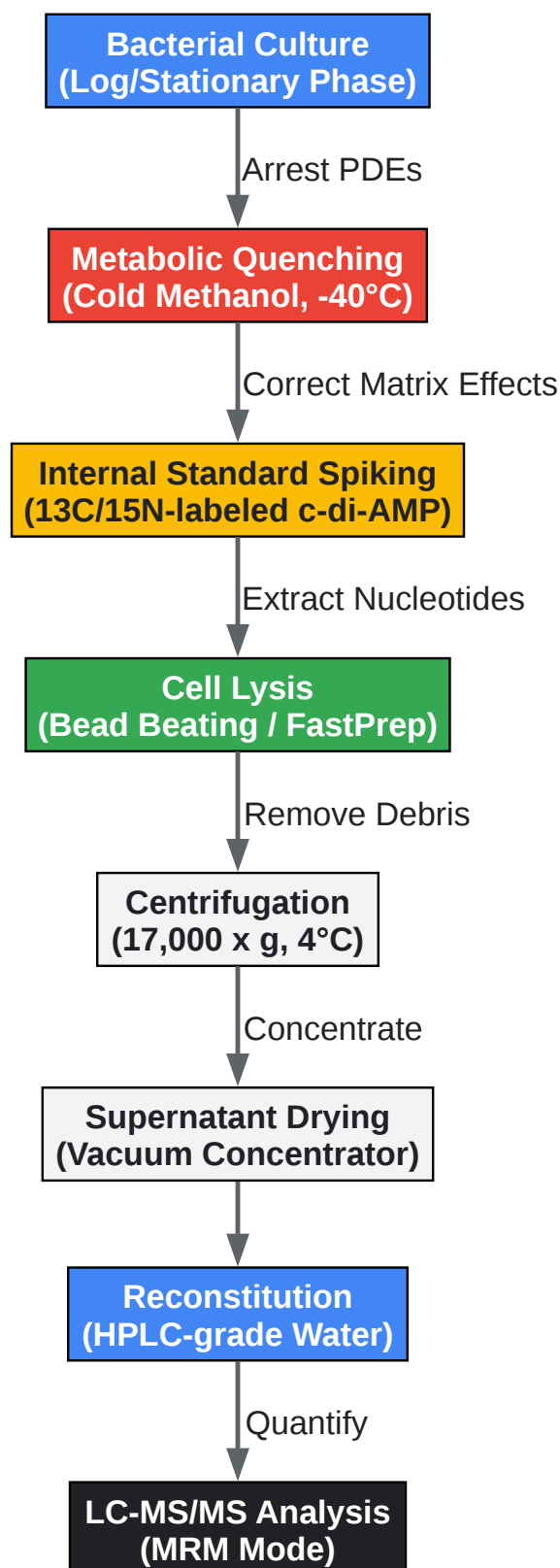

[Click to download full resolution via product page](#)

Fig 2: Optimized LC-MS/MS extraction workflow for intracellular c-di-AMP quantification.

## Step-by-Step Methodology

- Metabolic Quenching & Harvesting
  - Action: Rapidly plunge 5 mL of liquid bacterial culture directly into 10 mL of pre-chilled (-40°C) 60% methanol. Centrifuge at 10,000 x g for 5 min at -9°C.
  - Causality: c-di-AMP is rapidly hydrolyzed by PDEs like GdpP. The immediate temperature drop and solvent denaturation permanently arrest PDE activity, locking the in vivo metabolite pool in its native state [1](#).
- Internal Standard (IS) Spiking
  - Action: Resuspend the cell pellet in 500 µL of extraction solvent (Acetonitrile/Methanol/Water, 40:40:20, v/v/v) spiked with exactly 50 nM of heavy-labeled  $^{13}\text{C}_{10},^{15}\text{N}_5$ -c-di-AMP.
  - Causality: Matrix effects from bacterial lipids severely suppress MS ionization. Spiking the heavy isotope before lysis ensures that any physical loss during extraction or ion suppression in the MS is mathematically normalized [3](#).
- Mechanical Lysis
  - Action: Transfer the suspension to tubes containing 0.1 mm silica beads. Process in a FastPrep homogenizer (6.5 m/s, 45 s, 4 cycles) at 4°C.
  - Causality: Gram-positive bacteria possess thick peptidoglycan layers. Chemical lysis is insufficient and can degrade nucleotides; mechanical shearing is required for the complete release of cytosolic contents [4](#).
- Clarification & Reconstitution
  - Action: Centrifuge the lysate at 17,000 x g for 10 min at 4°C. Transfer the supernatant to a new tube, dry completely in a vacuum concentrator, and reconstitute in 50 µL of HPLC-grade water.
  - Causality: Removing cellular debris prevents LC column clogging. Vacuum drying concentrates the low-abundance analyte into the detectable range of the instrument [2](#).

- LC-MS/MS Analysis & Self-Validation
  - Action: Inject 10  $\mu$ L onto a C18 column. Operate the mass spectrometer in Multiple Reaction Monitoring (MRM) positive ion mode ( $m/z$  659.1  $\rightarrow$  330.1 for native c-di-AMP;  $m/z$  674.1  $\rightarrow$  338.1 for the heavy IS).
  - Validation System: Run a 6-point calibration curve (1 nM to 1  $\mu$ M) alongside samples. The IS peak area must remain within  $\pm 15\%$  across all biological injections to validate extraction efficiency.

## Protocol II: In Vivo Fluorescent Biosensor Measurement

While LC-MS/MS provides absolute bulk quantification, it destroys the sample. To measure c-di-AMP dynamics at single-cell resolution, researchers utilize genetically encoded biosensors, such as the CDA5 FRET sensor<sup>3</sup> or the *bsuO* P6-4 RNA aptamer<sup>4</sup>.

### Step-by-Step Methodology (Using *bsuO* P6-4 RNA Biosensor)

- Biosensor Transformation & Expression
  - Action: Transform the target bacterial strain with a plasmid encoding the *bsuO* P6-4 RNA aptamer flanked by a tRNA scaffold.
  - Causality: The tRNA scaffold prevents rapid degradation of the RNA aptamer by endogenous bacterial RNases, dramatically increasing the half-life and stabilizing the fluorescent signal <sup>4</sup>.
- Culture & Fluorophore Incubation
  - Action: Grow cells to mid-log phase (OD<sub>600</sub> ~0.5). Supplement the media with 100  $\mu$ M of the cell-permeable fluorophore DFHBI-1T for 30 minutes prior to measurement.
  - Causality: The RNA aptamer itself is not fluorescent; it must bind the DFHBI-1T dye. Binding is strictly dependent on the allosteric conformational change induced by c-di-AMP docking.

- Single-Cell Flow Cytometry
  - Action: Analyze cells using a flow cytometer equipped with a FITC channel (excitation 488 nm, emission 530 nm).
  - Causality: Unlike bulk LC-MS/MS, flow cytometry captures subpopulation heterogeneity, revealing bimodal distributions of c-di-AMP levels during environmental shifts like osmotic shock [5](#).
- Self-Validation System
  - Action: Include a  $\Delta cdaA$  /  $\Delta disA$  (cyclase-null) mutant as a negative control, and a  $\Delta gdpP$  (PDE-null) mutant as a positive control.
  - Causality: This genetic validation ensures that the observed fluorescence shift is exclusively driven by c-di-AMP fluctuations and not by artifacts such as changes in intracellular pH, cell volume, or non-specific dye accumulation [3](#).

## References

- Mahapa, A. et al. (2024). An HPLC-based Assay to Study the Activity of Cyclic Diadenosine Monophosphate (C-di-AMP) Synthase DisA from Mycobacterium smegmatis. Bio-protocol. URL:[\[Link\]](#)
- Kellenberger, C. A. et al. (2022). In Vivo Detection of Cyclic-di-AMP in Staphylococcus aureus. ACS Omega. URL:[\[Link\]](#)
- Pollock, J. et al. (2021). A Rationally Designed c-di-AMP Förster Resonance Energy Transfer Biosensor To Monitor Nucleotide Dynamics. Journal of Bacteriology. URL:[\[Link\]](#)
- Fahmi, T. et al. (2017). c-di-AMP: An Essential Molecule in the Signaling Pathways that Regulate the Viability and Virulence of Gram-Positive Bacteria. MDPI Genes. URL:[\[Link\]](#)
- Pham, H. T. et al. (2021). c-di-AMP, a likely master regulator of bacterial K<sup>+</sup> homeostasis machinery, activates a K<sup>+</sup> exporter. PNAS. URL:[\[Link\]](#)

### Need Custom Synthesis?

BenchChem offers custom synthesis for rare earth carbides and specific isotopic labeling.

Email: [info@benchchem.com](mailto:info@benchchem.com) or [Request Quote Online](#).

## Sources

- [1. c-di-AMP: An Essential Molecule in the Signaling Pathways that Regulate the Viability and Virulence of Gram-Positive Bacteria | MDPI \[mdpi.com\]](#)
- [2. bio-protocol.org \[bio-protocol.org\]](#)
- [3. journals.asm.org \[journals.asm.org\]](#)
- [4. pubs.acs.org \[pubs.acs.org\]](#)
- [5. pnas.org \[pnas.org\]](#)
- To cite this document: BenchChem. [Application Note: Advanced Methodologies for the Quantification of Intracellular c-di-AMP]. BenchChem, [2026]. [Online PDF]. Available at: [<https://www.benchchem.com/product/b1150292/docs#application-note-advanced-methodologies-for-the-quantification-of-intracellular-c-di-amp>]

---

### Disclaimer & Data Validity:

The information provided in this document is for Research Use Only (RUO) and is strictly not intended for diagnostic or therapeutic procedures. While BenchChem strives to provide accurate protocols, we make no warranties, express or implied, regarding the fitness of this product for every specific experimental setup.

**Technical Support:** The protocols provided are for reference purposes. Unsure if this reagent suits your experiment?

**Need Industrial/Bulk Grade?** [Request Custom Synthesis Quote](#)

# BenchChem

Our mission is to be the trusted global source of essential and advanced chemicals, empowering scientists and researchers to drive progress in science and industry.

## Contact

Address: 3281 E Guasti Rd

Ontario, CA 91761, United States

Phone: (601) 213-4426

Email: [info@benchchem.com](mailto:info@benchchem.com)

[Contact our Ph.D. Support Team for a compatibility check](#)