

protocol for derivatization of fatty acids with 3-Methyl-4-nitrobenzyl bromide

Author: BenchChem Technical Support Team. **Date:** January 2026

Compound of Interest

Compound Name: 3-Methyl-4-nitrobenzyl bromide

Cat. No.: B115719

[Get Quote](#)

An Application Guide and Protocol for the Derivatization of Fatty Acids with **3-Methyl-4-nitrobenzyl bromide**

For Researchers, Scientists, and Drug Development Professionals

Introduction: Enhancing Fatty Acid Analysis through Derivatization

Fatty acids (FAs) are fundamental to numerous biological processes, serving as energy sources, structural components of cell membranes, and signaling molecules.[1][2][3] Their accurate quantification is therefore critical in metabolic research, diagnostics, and the development of therapeutics for diseases such as cancer, diabetes, and cardiovascular disorders.[3][4]

However, the direct analysis of free fatty acids by modern analytical techniques like High-Performance Liquid Chromatography (HPLC) and Liquid Chromatography-Mass Spectrometry (LC-MS) presents significant challenges. In their underivatized form, the high polarity of the carboxylic acid group can lead to poor chromatographic peak shape and adsorption issues. Furthermore, FAs often exhibit poor ionization efficiency in mass spectrometry, limiting analytical sensitivity.[1][2]

Chemical derivatization addresses these limitations by converting the polar carboxyl group into a less polar ester. This process not only improves chromatographic behavior but can also

introduce a chemical moiety that enhances detectability. **3-Methyl-4-nitrobenzyl bromide** is an effective derivatizing agent for this purpose. The reaction converts the fatty acid into its 3-methyl-4-nitrobenzyl ester, which incorporates a strong chromophore (the nitroaromatic group) for sensitive UV detection and a group that facilitates ionization for mass spectrometry analysis. [5][6] This application note provides a detailed protocol for the derivatization of fatty acids using **3-Methyl-4-nitrobenzyl bromide**, explains the underlying chemical principles, and offers guidance for subsequent analysis.

Principle of the Derivatization Reaction

The derivatization of a fatty acid with **3-Methyl-4-nitrobenzyl bromide** is a classic bimolecular nucleophilic substitution (SN2) reaction. The process involves two key steps:

- **Deprotonation:** A weak organic base, such as triethylamine (TEA) or N,N-diisopropylethylamine (DIPEA), is used to deprotonate the carboxylic acid group of the fatty acid. This generates a carboxylate anion, which is a much stronger nucleophile than the neutral carboxylic acid.
- **Nucleophilic Attack:** The newly formed carboxylate anion attacks the electrophilic benzylic carbon of **3-Methyl-4-nitrobenzyl bromide**. This attack displaces the bromide ion, a good leaving group, resulting in the formation of the corresponding 3-methyl-4-nitrobenzyl ester.

The reaction is typically performed in an aprotic polar solvent, such as acetone or acetonitrile, which can solvate the ions without interfering with the reaction. Heating is often employed to increase the reaction rate.

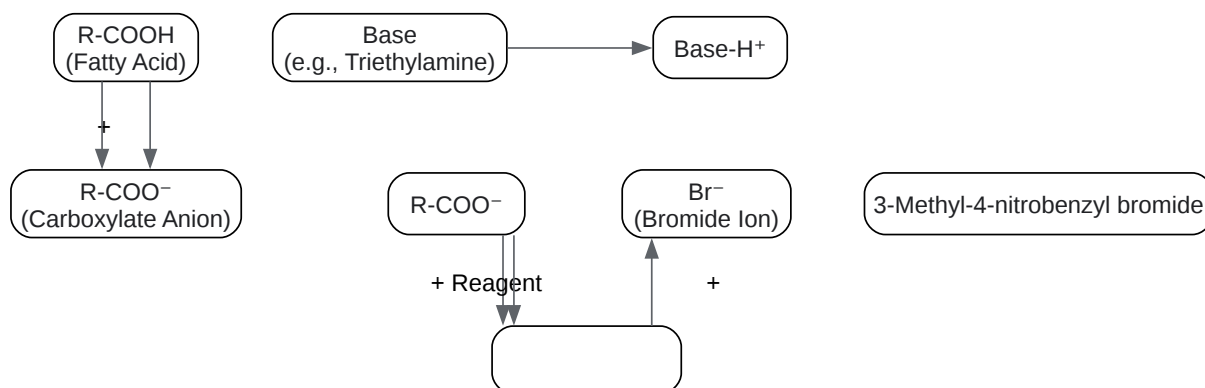

[Click to download full resolution via product page](#)

Caption: Reaction mechanism for fatty acid derivatization.

Materials and Reagents

Item	Recommended Grade/Specification
Reagents	
Fatty Acid Standard(s) or Sample Extract	High Purity (>98%)
3-Methyl-4-nitrobenzyl bromide	Derivatization Grade (>98%)
Triethylamine (TEA) or DIPEA	HPLC Grade, >99%
Acetonitrile (ACN) or Acetone	HPLC Grade, anhydrous
Hexane	HPLC Grade
Water	HPLC or Milli-Q Grade
Acetic Acid	Glacial, ACS Grade
Anhydrous Sodium Sulfate	ACS Grade, granular
Equipment & Consumables	
Micro-reaction vials (e.g., 2 mL) with caps	PTFE-lined caps
Heating block or water bath	Capable of maintaining $\pm 1^\circ\text{C}$
Pipettors and tips	Calibrated
Vortex mixer	
Centrifuge	For separating layers if needed
Syringe filters	0.22 μm PTFE for organic solvents
HPLC or LC-MS autosampler vials with inserts	

Causality Behind Choices:

- **Anhydrous Solvents:** The presence of water can hinder the esterification reaction. It is crucial to use high-purity, dry solvents to ensure a high reaction yield.
- **High-Purity Reagents:** Impurities in the derivatization reagent or base can lead to artifact peaks in the chromatogram, complicating analysis.

Detailed Experimental Protocol

This protocol is a robust starting point and may require optimization depending on the specific fatty acids and sample matrix.

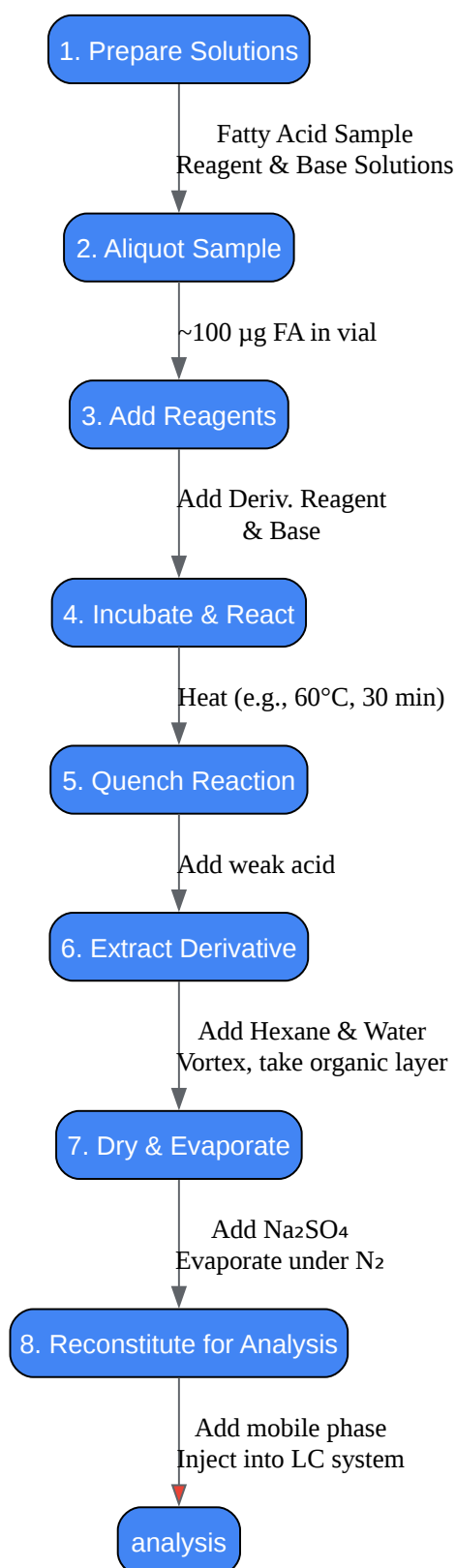

[Click to download full resolution via product page](#)

Caption: Workflow for fatty acid derivatization and analysis.

Step 1: Preparation of Reagent Solutions

- Derivatization Reagent: Prepare a 10 mg/mL solution of **3-Methyl-4-nitrobenzyl bromide** in anhydrous acetonitrile.
- Catalyst Solution: Prepare a 10 mg/mL solution of triethylamine in anhydrous acetonitrile.
- Self-Validation: These solutions should be prepared fresh daily to prevent degradation of the reagents.

Step 2: Sample Preparation

- Accurately transfer a known amount of the fatty acid sample (e.g., 10-100 µg) into a 2 mL micro-reaction vial.
- If the sample is in a solid form or a different solvent, evaporate it to complete dryness under a gentle stream of nitrogen.
- Dissolve the dried residue in 100 µL of anhydrous acetonitrile.

Step 3: Derivatization Reaction

- To the sample vial, add 50 µL of the **3-Methyl-4-nitrobenzyl bromide** solution.
- Add 20 µL of the triethylamine solution.
- Cap the vial tightly, vortex for 30 seconds, and briefly centrifuge to ensure all liquid is at the bottom.
- Causality: The base is added to deprotonate the acid, making it nucleophilic. An excess of the derivatizing agent is used to drive the reaction to completion.

Step 4: Incubation

- Place the vial in a heating block or water bath set to 60°C.
- Incubate for 30 minutes. Reaction times and temperatures may need optimization; 40-80°C and 20-60 minutes are typical starting ranges.[5]

- **Trustworthiness:** To determine the optimal derivatization time, analyze aliquots of a representative sample at different time points (e.g., 15, 30, 45, 60 minutes) and plot the peak area of the derivative versus time. The optimal time is where the peak area plateaus.

Step 5: Reaction Quenching and Work-up

- After incubation, cool the vial to room temperature.
- To stop the reaction, add 10 μL of a 1% acetic acid solution in acetonitrile. This neutralizes the excess triethylamine.[5]
- Add 500 μL of HPLC-grade water and 500 μL of hexane to the vial.
- Vortex vigorously for 1 minute to extract the derivatized fatty acids into the organic (hexane) layer. The underivatized acids and excess reagents will preferentially stay in the aqueous layer.
- Centrifuge for 5 minutes at $\sim 2000 \times g$ to achieve a clean separation of the layers.

Step 6: Sample Finalization

- Carefully transfer the upper hexane layer to a clean vial, taking care not to disturb the aqueous layer.
- Add a small amount of anhydrous sodium sulfate to the hexane extract to remove any residual water.
- Evaporate the hexane to dryness under a gentle stream of nitrogen.
- Reconstitute the dried residue in a known volume (e.g., 100-200 μL) of the initial mobile phase for your LC analysis (e.g., 80:20 acetonitrile:water).
- Filter the final solution through a 0.22 μm syringe filter into an autosampler vial. The sample is now ready for injection.

Analysis of 3-Methyl-4-nitrobenzyl Esters

The resulting derivatives are well-suited for analysis by Reverse-Phase HPLC (RP-HPLC) coupled with either UV or mass spectrometry detection.

- HPLC-UV Analysis: The nitrobenzyl group provides a strong UV absorbance, typically maximal around 254-260 nm.^[5] This allows for sensitive detection using a standard Diode Array Detector (DAD) or UV detector.
- LC-MS Analysis: Derivatization significantly enhances sensitivity in mass spectrometry. The ester derivatives can be readily detected in positive ion mode using electrospray ionization (ESI), often as $[M+H]^+$ or $[M+Na]^+$ adducts. The defined structure of the derivative also provides predictable fragmentation patterns in MS/MS (tandem mass spectrometry), which is invaluable for targeted quantification using Multiple Reaction Monitoring (MRM).^[4]

Troubleshooting and Best Practices

Problem	Potential Cause(s)	Solution(s)
Low or No Derivative Peak	Incomplete reaction; presence of water; degraded reagents.	Increase reaction time/temperature. Ensure all solvents are anhydrous. Prepare fresh reagent solutions.
Multiple Derivative Peaks	Side reactions; presence of isomers in the original sample.	Lower reaction temperature to minimize side products. Verify the purity of the fatty acid standard. Some isomers may not be chromatographically separated.[6]
High Background/Artifacts	Contaminated reagents or solvents; dirty glassware.	Use high-purity (HPLC or derivatization grade) reagents and solvents. Ensure all glassware is scrupulously clean. Run a reagent blank (no fatty acid).
Poor Peak Shape	Inappropriate reconstitution solvent; column overload; poor chromatography.	Reconstitute in a solvent weaker than or equal to the initial mobile phase. Inject a smaller volume or dilute the sample. Optimize the LC gradient.

References

- Czauderna, M., et al. (n.d.). A highly efficient method for derivatization of fatty acids for high performance liquid chromatography. *Journal of Animal and Feed Sciences*.
- Kalogianni, D. P., et al. (2022). Liquid Chromatography-Mass Spectrometry (LC-MS) Derivatization-Based Methods for the Determination of Fatty Acids in Biological Samples. National Center for Biotechnology Information.
- Gresti, J., et al. (1993). High performance liquid chromatography of fatty acids as naphthacyl derivatives. *Analisis*.

- Han, P., et al. (2014). HPLC-MRM relative quantification analysis of fatty acids based on a novel derivatization strategy. PubMed.
- Nacalai Tesque. (n.d.). Fatty Acid Analysis by HPLC.
- Kalogianni, D. P., et al. (2022). Liquid Chromatography-Mass Spectrometry (LC-MS) Derivatization-Based Methods for the Determination of Fatty Acids in Biological Samples. ResearchGate.
- Shimadzu. (n.d.). LC/MS/MS Method Package for Short Chain Fatty Acids.
- Ma, J., et al. (2021). A liquid chromatography-mass spectrometry workflow for in-depth quantitation of fatty acid double bond location isomers. PubMed Central.

Need Custom Synthesis?

BenchChem offers custom synthesis for rare earth carbides and specific isotopic labeling.

Email: info@benchchem.com or [Request Quote Online](#).

Sources

- 1. Liquid Chromatography-Mass Spectrometry (LC-MS) Derivatization-Based Methods for the Determination of Fatty Acids in Biological Samples - PMC [pmc.ncbi.nlm.nih.gov]
- 2. researchgate.net [researchgate.net]
- 3. Choosing the Right LC-MS Platform for Fatty Acid Analysis - Creative Proteomics [creative-proteomics.com]
- 4. HPLC-MRM relative quantification analysis of fatty acids based on a novel derivatization strategy - PubMed [pubmed.ncbi.nlm.nih.gov]
- 5. jafs.com.pl [jafs.com.pl]
- 6. analisis.edpsciences.org [analisi.edpsciences.org]
- To cite this document: BenchChem. [protocol for derivatization of fatty acids with 3-Methyl-4-nitrobenzyl bromide]. BenchChem, [2026]. [Online PDF]. Available at: [https://www.benchchem.com/product/b115719#protocol-for-derivatization-of-fatty-acids-with-3-methyl-4-nitrobenzyl-bromide]

Disclaimer & Data Validity:

The information provided in this document is for Research Use Only (RUO) and is strictly not intended for diagnostic or therapeutic procedures. While BenchChem strives to provide accurate protocols, we make no warranties, express or implied, regarding the fitness of this product for every specific experimental setup.

Technical Support: The protocols provided are for reference purposes. Unsure if this reagent suits your experiment? [[Contact our Ph.D. Support Team for a compatibility check](#)]

Need Industrial/Bulk Grade? [Request Custom Synthesis Quote](#)

BenchChem

Our mission is to be the trusted global source of essential and advanced chemicals, empowering scientists and researchers to drive progress in science and industry.

Contact

Address: 3281 E Guasti Rd
Ontario, CA 91761, United States
Phone: (601) 213-4426
Email: info@benchchem.com