

Technical Guide: Characterization of Oxirane-d, 2-(chloromethyl-d2)

Author: BenchChem Technical Support Team. **Date:** May 2026

Compound of Interest

Compound Name: Oxirane-d,2-(chloroMethyl-d2)

CAS No.: 159301-46-9

Cat. No.: B1149577

[Get Quote](#)

Executive Summary & Chemical Identity

Oxirane-d, 2-(chloromethyl-d2) is a specific isotopologue of epichlorohydrin where the methine proton on the oxirane ring and the two methylene protons on the chloromethyl group are replaced by deuterium. This distinct labeling pattern (

) renders the molecule "silent" in specific regions of the

¹H NMR spectrum while providing a mass shift of +3 Da, making it an ideal internal standard for Mass Spectrometry (MS) and Nuclear Magnetic Resonance (NMR) quantification workflows.

Structural Specification

- IUPAC Name: 2-(Chloromethyl-

)oxirane-2-
- Common Name: Epichlorohydrin-

(specifically labeled at C2 and C

)

- Molecular Formula:
- Molecular Weight: ~95.54 g/mol (based on Cl)
- Chemical Structure:
 - Ring Position 2 (Methine): Deuterated ().
 - Side Chain (Chloromethyl): Deuterated ().
 - Ring Position 3 (Methylene): Protonated ().

NMR Spectroscopy Profiling

The deuteration of the methine (C2) and chloromethyl (C

) positions drastically simplifies the

¹H NMR spectrum compared to native epichlorohydrin (

).

Predicted ¹H NMR Data (vs. Native)

The native

spectrum is a complex ABCDE system due to the chiral center at C2, creating diastereotopic protons on both methylene groups. The

analog collapses this into a simplified AB system.

Position	Proton Type	Native () Shift (ppm)	Multiplicity ()	Target () Shift (ppm)	Multiplicity ()
Ring C3	Methylene ()	2.68	dd (Doublet of Doublets)	2.66	d (Doublet)
Ring C3	Methylene ()	2.89	dd	2.87	d (Doublet)
Ring C2	Methine ()	3.23	m (Multiplet)	Silent	-
Side Chain	Chloromethyl ()	3.57 - 3.60	dd / m	Silent	-

Key Spectral Features:

- **Signal Silencing:** The signals at 3.23 ppm (methine) and the 3.57-3.60 ppm region (chloromethyl) will disappear completely.
- **Coupling Collapse:** In the native spectrum, the ring methylene protons () couple to the methine proton () with Hz. In the analog, is replaced by Deuterium (). Since is

of

, the vicinal coupling is effectively removed at standard field strengths, leaving

and

coupled only to each other (Geminal coupling,

Hz).

- Isotope Shift: A slight upfield shift (

ppm) is expected for the remaining protons due to the intrinsic isotope effect of the adjacent deuteriums.

C NMR Data

- C-Cl (Side Chain): Appears as a quintet (coupling to two D nuclei, Hz).
- C-Ring (Methine): Appears as a triplet (coupling to one D nucleus).
- C-Ring (Methylene): Appears as a singlet (or broadened due to long-range coupling).

Mass Spectrometry (GC-MS) Data

For quantification of genotoxic impurities, Selected Ion Monitoring (SIM) is the standard. The analog provides a distinct mass channel free from natural isotope interference.

Ionization & Fragmentation (EI, 70eV)

Epichlorohydrin typically fragments via

-cleavage or loss of the chlorine atom.

Fragment Ion	Native () m/z	Target () m/z	Interpretation
Molecular Ion ()	92 (Cl) / 94 (Cl)	95 (Cl) / 97 (Cl)	Parent Molecule
	57	60	Loss of Cl atom (Ring intact)
	43	43	Loss of side chain (Only ring remains)
	49 / 51	51 / 53	Side chain fragment ()

Note on Fragment 43: If the fragmentation pathway involves the loss of the chloromethyl group, the remaining fragment is the oxirane ring (

).

In the analog, the ring retains one deuterium (C2-D) and two protons (C3-

).

Therefore, the fragment would appear at m/z 44, not 43. This shift is crucial for confirmation.

Fragmentation Pathway Visualization

The following diagram illustrates the theoretical fragmentation logic for the

analog.

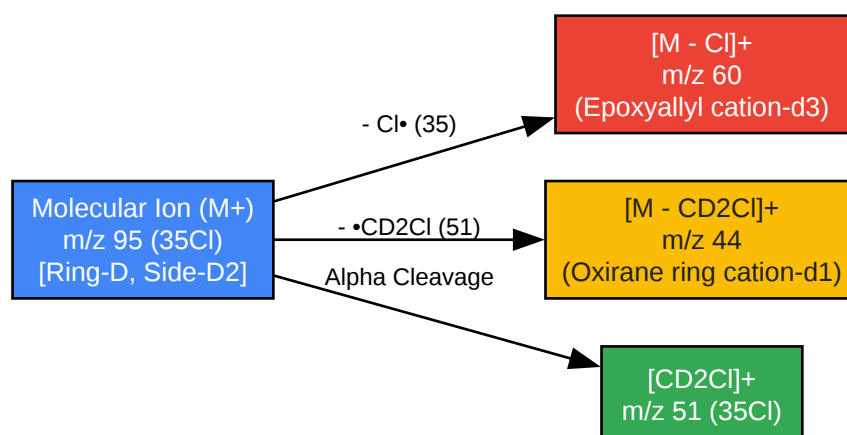

Figure 1: EI Fragmentation Pathway for Oxirane-d, 2-(chloromethyl-d2)

[Click to download full resolution via product page](#)

Caption: Theoretical Electron Ionization (EI) fragmentation pathway showing mass shifts relative to native epichlorohydrin.

Experimental Protocols

Protocol: Trace Quantification by GC-MS (SIM Mode)

This protocol is designed for detecting epichlorohydrin impurities in drug substances using the analog as an Internal Standard (IS).

Reagents:

- Analyte: Epichlorohydrin ([\[1\]](#)[\[2\]](#)[\[3\]](#)[\[4\]](#)[\[5\]](#))
- Internal Standard: Oxirane-d, 2-(chloromethyl-d2) ()
- Solvent: Dichloromethane (DCM) or Tetrahydrofuran (THF), HPLC Grade.

Step-by-Step Methodology:

- Stock Preparation:

- Prepare a 1.0 mg/mL stock solution of the
IS in DCM.
- Store at -20°C (Epichlorohydrin is volatile and reactive).
- Sample Extraction:
 - Weigh 100 mg of the pharmaceutical drug substance (API).
 - Dissolve in 5.0 mL of DCM containing the IS at a concentration of 1.0
g/mL.
 - Vortex for 60 seconds; Centrifuge if insoluble excipients are present.
- GC-MS Parameters:
 - Column: DB-624 or equivalent (volatile specific), 30m x 0.25mm ID.
 - Carrier Gas: Helium at 1.0 mL/min.
 - Oven Program: 40°C (hold 2 min)
10°C/min
200°C.
 - Inlet: Splitless mode, 200°C.
- MS Detection (SIM Mode):
 - Target (
): Monitor m/z 57 (Quant), 49 (Qual).
 - IS (
): Monitor m/z 60 (Quant), 51 (Qual).
 - Note: Avoid m/z 62 (

with

Cl) overlapping with m/z 60 unless resolution is sufficient.

Protocol: NMR Purity Assay

Used to verify the isotopic enrichment of the standard.

- Sample Prep: Dissolve ~10 mg of standard in 0.6 mL (ensure solvent is acid-free to prevent ring opening).
- Acquisition:
 - Pulse Angle: 30°. [6]
 - Relaxation Delay (): 10 seconds (to allow full relaxation of protons with no NOE).
 - Scans: 16-64.
- Analysis: Integrate the residual signals at 3.23 ppm and 3.57 ppm. Compare integrals to the 2.6-2.9 ppm region to calculate % deuteration.

Analytical Workflow Diagram

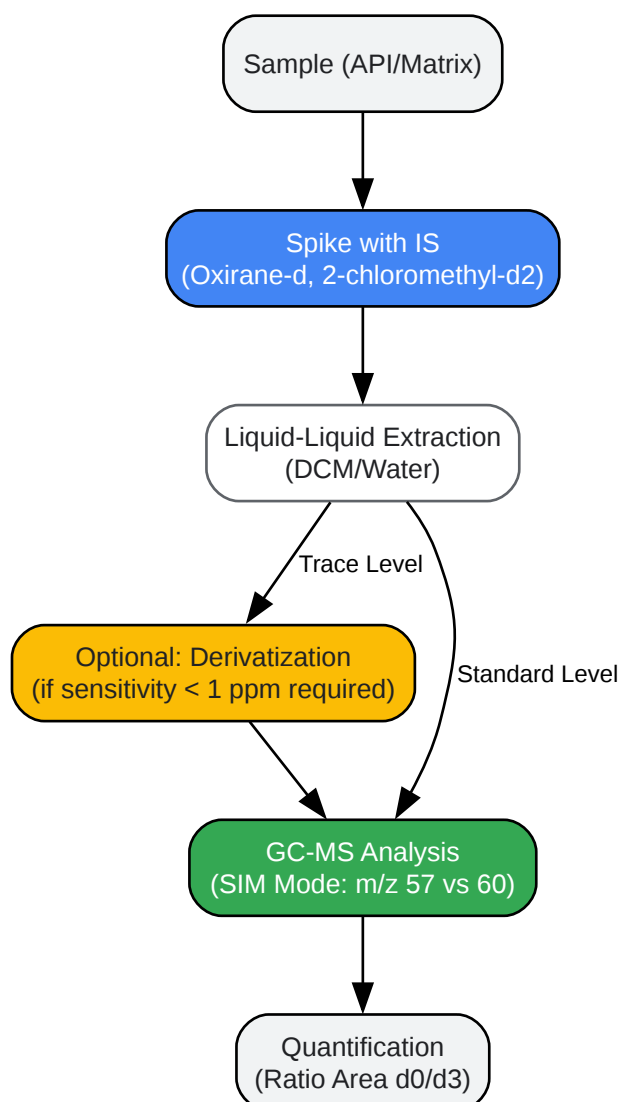

Figure 2: Analytical Workflow for GTI Quantification using Deuterated IS

[Click to download full resolution via product page](#)

Caption: Workflow for quantifying epichlorohydrin impurities using the d3-isotopologue as an internal standard.

References

- National Institute of Standards and Technology (NIST). Epichlorohydrin Mass Spectrum (Electron Ionization). NIST Chemistry WebBook, SRD 69. [[Link](#)]
- Simpson, T. J. Theory and Applications of Isotope Effects in NMR Spectroscopy. Annual Reports on NMR Spectroscopy, Vol 70, 2010. (General reference for H-D coupling)

constants).

Need Custom Synthesis?

BenchChem offers custom synthesis for rare earth carbides and specific isotopic labeling.

Email: info@benchchem.com or [Request Quote Online](#).

Sources

- [1. Page loading... \[wap.guidechem.com\]](#)
- [2. rsc.org \[rsc.org\]](#)
- [3. Epichlorohydrin - Wikipedia \[en.wikipedia.org\]](#)
- [4. Determination of epichlorohydrin by sulfite derivatization and ion chromatography: characterization of the sulfite derivatives by ion chromatography-mass spectrometry - PubMed \[pubmed.ncbi.nlm.nih.gov\]](#)
- [5. Solved The 1H NMR spectrum for the commonly | Chegg.com \[chegg.com\]](#)
- [6. researchgate.net \[researchgate.net\]](#)
- To cite this document: BenchChem. [Technical Guide: Characterization of Oxirane-d, 2-(chloromethyl-d2)]. BenchChem, [2026]. [Online PDF]. Available at: [\[https://www.benchchem.com/product/b1149577/docs#technical-guide-characterization-of-oxirane-d-2-chloromethyl-d2\]](https://www.benchchem.com/product/b1149577/docs#technical-guide-characterization-of-oxirane-d-2-chloromethyl-d2)

Disclaimer & Data Validity:

The information provided in this document is for Research Use Only (RUO) and is strictly not intended for diagnostic or therapeutic procedures. While BenchChem strives to provide accurate protocols, we make no warranties, express or implied, regarding the fitness of this product for every specific experimental setup.

Technical Support: The protocols provided are for reference purposes. Unsure if this reagent suits your experiment?

Need Industrial/Bulk Grade? [Request Custom Synthesis Quote](#)

BenchChem

Our mission is to be the trusted global source of essential and advanced chemicals, empowering scientists and researchers to drive progress in science and industry.

Contact

Address: 3281 E Guasti Rd

Ontario, CA 91761, United States

Phone: (601) 213-4426

Email: info@benchchem.com

[Contact our Ph.D. Support Team for a compatibility check](#)