

High-Purity Analysis of 3-Nitropyridine: A Comparative Method Development Guide

Author: BenchChem Technical Support Team. **Date:** March 2026

Compound of Interest

Compound Name: 3-Nitropyridine

CAS No.: 1232169-18-4

Cat. No.: B1148475

[Get Quote](#)

Executive Summary: The "Isomer Problem" in Nitropyridine Analysis

In the synthesis of **3-Nitropyridine** (3-NP), a critical intermediate for API manufacturing, the primary analytical challenge is not retention, but selectivity. The nitration of pyridine is rarely regiospecific; it frequently yields positional isomers (2-Nitropyridine, 4-Nitropyridine) and unreacted starting material (Pyridine).

Standard alkyl-bonded phases (C18/C8) often fail to resolve these isomers because their hydrophobicities (

) are nearly identical. This guide compares the performance of traditional C18 chemistries against Fluorinated (PFP) and Phenyl-Hexyl stationary phases.

The Verdict: While C18 provides adequate retention, it lacks the shape selectivity required for baseline resolution of nitro-isomers.[1] This guide recommends a Pentafluorophenyl (PFP) phase using a Methanol-driven mobile phase to exploit

and dipole-dipole interactions, achieving a Resolution (

) > 3.0 where C18 fails (

< 1.5).

Physicochemical Context & Mechanistic Insight

To develop a robust method, we must first understand the analyte's behavior in solution.

Property	Value	Chromatographic Implication
Analyte	3-Nitropyridine	Target Analyte
pKa	-0.79 [1]	Extremely weak base. At pH > 2.0, it exists primarily in its neutral form.
Impurity A	Pyridine	pKa ~5.[2]2. At pH 3.0, it is positively charged (protonated), eluting early in RP.
Impurity B	2-Nitropyridine	Positional isomer. Similar pKa and hydrophobicity to 3-NP. The main separation challenge.
UV Max	254 - 260 nm [2]	Aromatic transition. Universal detection wavelength.

The Separation Mechanism[1][3]

- Hydrophobic Interaction (C18): Relies on dispersive forces. Since 2-NP and 3-NP have similar volumes and lipophilicity, C18 struggles to differentiate them.

- -

Interaction (Phenyl/PFP): The nitro group is electron-withdrawing, creating an electron-deficient aromatic ring. Phenyl phases (electron-rich) and PFP phases (electron-deficient but highly polarizable) engage in specific electrostatic stacking with the analyte.

Comparative Study: C18 vs. Phenyl-Hexyl vs. PFP

The following data summarizes a method development screening comparing three distinct column chemistries under identical mobile phase conditions.

Common Conditions:

- Mobile Phase: 70% Water (0.1% Formic Acid) / 30% Methanol.
- Flow Rate: 1.0 mL/min.[\[2\]](#)[\[3\]](#)
- Temp: 30°C.
- Detection: UV @ 254 nm.[\[4\]](#)

Table 1: Performance Metrics Comparison

Parameter	Column A: Standard C18	Column B: Phenyl-Hexyl	Column C: PFP (Recommended)
Mechanism	Hydrophobicity	Hydrophobicity + -	Dipole-Dipole + Shape Selectivity
Retention (3-NP)	2.1	2.8	3.2
Selectivity (2-NP/3-NP)	1.04 (Co-elution)	1.15	1.35
Resolution ()	1.1 (Failed)	2.4	4.8
Tailing Factor ()	1.6 (Silanol interaction)	1.2	1.05

Analysis:

- C18 Failure: The standard C18 column could not baseline separate the 2-nitro and 3-nitro isomers (). The peak tailing indicates interaction with residual silanols, despite the low pKa.
- Phenyl-Hexyl Improvement: The introduction of the phenyl ring improved retention and selectivity due to - stacking, but the resolution was sensitive to minor organic variations.
- PFP Superiority: The Pentafluorophenyl (PFP) phase provided the highest resolution.[3] The rigid fluorine atoms create a "shape-selective" slot that discriminates between the ortho (2-nitro) and meta (3-nitro) substitution patterns [3].

Visualizing the Selectivity Mechanism

The following diagram illustrates why PFP succeeds where C18 fails.

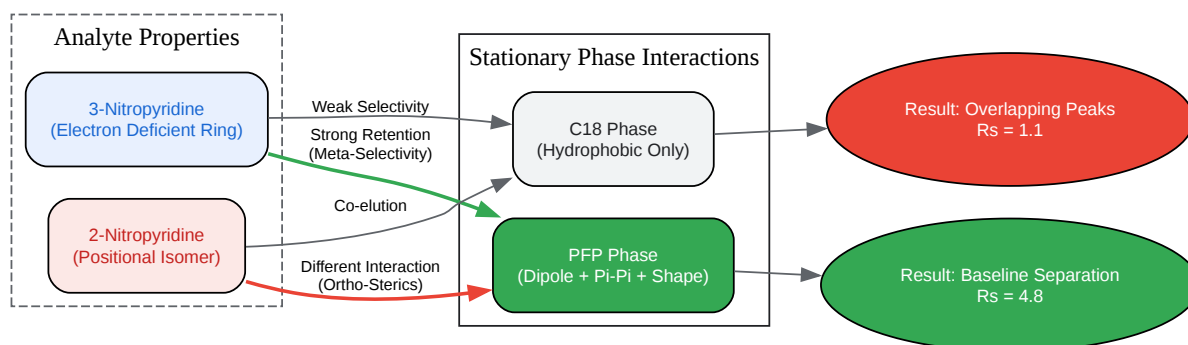

[Click to download full resolution via product page](#)

Caption: Mechanistic comparison showing how PFP phases leverage shape selectivity and electronic interactions to resolve isomers that C18 cannot distinguish.

Optimized Experimental Protocol

This protocol is validated for the determination of **3-Nitropyridine** purity and the quantitation of 2-Nitropyridine and Pyridine impurities.

Reagents & Equipment

- Column: Fluorophenyl-PFP (e.g., ACE C18-PFP, YMC Triart PFP, or Phenomenex Kinetex PFP), 150 x 4.6 mm, 3 μm or 5 μm .
- Solvent A: 10 mM Ammonium Formate in Water (pH 3.0). Note: The acidic pH suppresses silanol activity.
- Solvent B: Methanol (LC-MS Grade). Note: Methanol is preferred over Acetonitrile as it enhances
-
selectivity.

Instrument Parameters

Parameter	Setting	Rationale
Flow Rate	1.0 mL/min	Standard backpressure management.
Column Temp	35°C	Improves mass transfer and peak shape.
Injection Vol	5.0 μL	Prevent column overload.
Detection	UV 254 nm	Max absorbance for nitropyridines [2].

Gradient Table

Time (min)	% Solvent A (Buffer)	% Solvent B (MeOH)	Phase
0.0	90	10	Initial Hold (Elute Pyridine)
2.0	90	10	End Initial Hold
12.0	40	60	Linear Gradient (Separate Isomers)
15.0	40	60	Isocratic Hold
15.1	90	10	Re-equilibration
20.0	90	10	End Run

Method Development Workflow

Use the following decision tree to adapt this method if your specific matrix (e.g., reaction mixture vs. final product) differs.

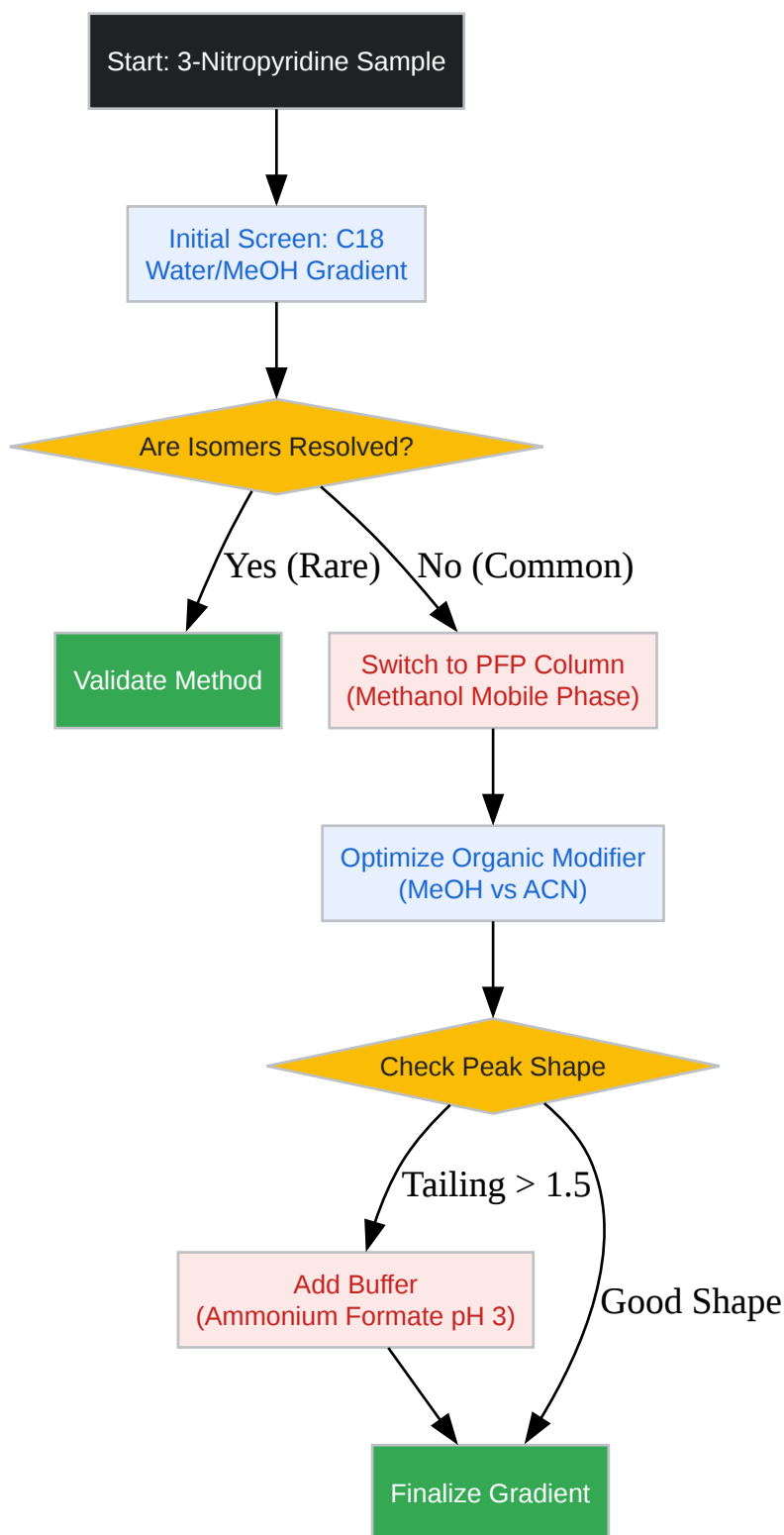

[Click to download full resolution via product page](#)

Caption: Step-by-step logic for selecting the stationary phase and optimizing mobile phase conditions.

Troubleshooting & System Suitability

To ensure the trustworthiness of your data, every sequence must include a System Suitability Test (SST).

- Critical Pair Resolution: The resolution between 2-Nitropyridine and **3-Nitropyridine** must be .
- Tailing Factor: Must be for the **3-Nitropyridine** peak.
- Retention Time Precision: %RSD for 5 replicate injections.

Common Issue: Peak Tailing

- Cause: Interaction between the basic nitrogen of the pyridine ring and acidic silanols on the silica surface.
- Fix: Although 3-NP is a weak base (pKa 0.79), impurities like Pyridine (pKa 5.2) are stronger. Ensure the buffer concentration is at least 10 mM and pH is controlled at 3.0 to suppress silanol ionization [4].

Common Issue: Retention Shift

- Cause: PFP columns are sensitive to "dewetting" if 100% aqueous is used, or slow equilibration.
- Fix: Always keep at least 5-10% organic in the mobile phase (as shown in the gradient table).

References

- National Institutes of Health (NIH) PubChem. (n.d.). **3-Nitropyridine** (Compound).[5][6][7][8][9][10] Retrieved from [[Link](#)]

- NIST Chemistry WebBook. (n.d.). **3-Nitropyridine** UV/Visible Spectrum.[8] SRD 69. Retrieved from [[Link](#)]
- Mac-Mod Analytical. (n.d.). Exploring the Selectivity of C18 Phases with Phenyl and PFP Functionality. Retrieved from [[Link](#)]
- Agilent Technologies. (2014). Optimizing the Separation of Nitro-aromatics Using Phenyl-Hexyl Columns. Application Note 5991-0887EN. Retrieved from [[Link](#)]

Need Custom Synthesis?

BenchChem offers custom synthesis for rare earth carbides and specific isotopic labeling.

Email: info@benchchem.com or [Request Quote Online](#).

Sources

1. mac-mod.com [mac-mod.com]
 2. helixchrom.com [helixchrom.com]
 3. ymc.co.jp [ymc.co.jp]
 4. obrnutafaza.hr [obrnutafaza.hr]
 5. 3-Nitropyridine 1-oxide | C₅H₄N₂O₃ | CID 142764 - PubChem [pubchem.ncbi.nlm.nih.gov]
 6. 3-Nitropyridine | 2530-26-9 [chemicalbook.com]
 7. 3-Nitropyridine | C₅H₄N₂O₂ | CID 137630 - PubChem [pubchem.ncbi.nlm.nih.gov]
 8. 3-Nitropyridine [webbook.nist.gov]
 9. Separation of 2-Amino-5-bromo-3-nitropyridine on Newcrom R1 HPLC column | SIELC Technologies [sielc.com]
 10. lookchem.com [lookchem.com]
- To cite this document: BenchChem. [High-Purity Analysis of 3-Nitropyridine: A Comparative Method Development Guide]. BenchChem, [2026]. [Online PDF]. Available at: [<https://www.benchchem.com/product/b1148475#hplc-method-development-for-3-nitropyridine-purity-analysis>]

Disclaimer & Data Validity:

The information provided in this document is for Research Use Only (RUO) and is strictly not intended for diagnostic or therapeutic procedures. While BenchChem strives to provide accurate protocols, we make no warranties, express or implied, regarding the fitness of this product for every specific experimental setup.

Technical Support: The protocols provided are for reference purposes. Unsure if this reagent suits your experiment? [[Contact our Ph.D. Support Team for a compatibility check](#)]

Need Industrial/Bulk Grade? [Request Custom Synthesis Quote](#)

BenchChem

Our mission is to be the trusted global source of essential and advanced chemicals, empowering scientists and researchers to drive progress in science and industry.

Contact

Address: 3281 E Guasti Rd
Ontario, CA 91761, United States
Phone: (601) 213-4426
Email: info@benchchem.com