

Technical Guide: NMR Spectral Analysis & Synthesis of Acetaldehyde Diethyl Acetal-d3

Author: BenchChem Technical Support Team. **Date:** May 2026

Compound of Interest

Compound Name:	Acetaldehyde diethylacetal - d3
CAS No.:	92144-49-5
Cat. No.:	B1147749

[Get Quote](#)

Executive Summary

Acetaldehyde diethyl acetal-d3 (1,1-diethoxyethane-2,2,2-d3) serves as a critical stable isotope-labeled internal standard in metabolic profiling and pharmacokinetic studies. It is the protected form of Acetaldehyde-d3, preventing volatility loss and polymerization during analysis.

This technical guide provides a definitive reference for the characterization of this isotopologue. Unlike standard spectral databases that list only the parent compound, this guide synthesizes experimental data with isotopic shift logic to define the specific spectral signature of the d3-variant. It details the suppression of scalar coupling in

¹H NMR, the multiplet splitting in

¹³C NMR due to C-D coupling, and a validated synthesis protocol for laboratory preparation.

Chemical Identity & Structural Logic[1][2]

The d3-isotopologue differs from the parent compound by the substitution of the acetyl methyl protons with deuterium. This modification dramatically alters the magnetic resonance signature,

specifically at the acetal methine position.

Property	Data
IUPAC Name	1,1-Diethoxyethane-2,2,2-d3
Common Name	Acetaldehyde diethyl acetal-d3
CAS Number	105-57-7 (Parent); Isotopologue specific CAS varies by enrichment
Molecular Formula	
Molecular Weight	~121.19 g/mol (vs 118.17 for parent)
Isotopic Enrichment	Typically 98 atom % D

Structural Visualization & Labeling

The following diagram illustrates the carbon backbone and the specific deuteration site (C2) responsible for the spectral changes.

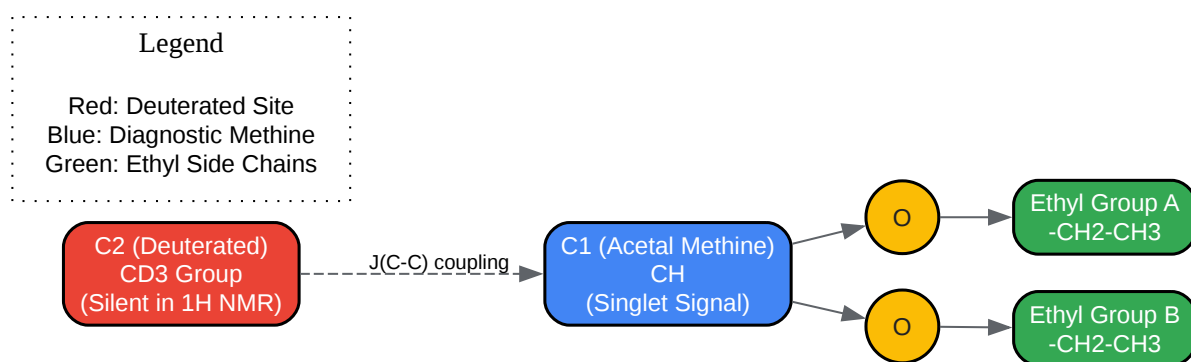

[Click to download full resolution via product page](#)

Figure 1: Structural connectivity of Acetaldehyde diethyl acetal-d3 highlighting the CD3 moiety (Red) which decouples the adjacent C1 methine proton (Blue).[1][2][3]

NMR Spectral Analysis

The spectral data below assumes a solvent of Chloroform-d (

) referenced to TMS (

0.00).

Proton (¹H) NMR Spectroscopy

The defining feature of the d3-variant is the collapse of the acetal methine quartet into a singlet.

In the non-deuterated parent, the methine proton at C1 couples with the methyl protons at C2 (

Hz). In the d3-variant, this coupling is removed.

Position	Shift (ppm)	Multiplicity	Integral	Assignment	Isotope Effect Note
C1-H	4.65	Singlet (s)	1H	Acetal Methine	Diagnostic: Collapsed from quartet due to loss of vicinal H-coupling. May appear slightly broadened due to weak
Ethyl	3.50 – 3.70	Multiplet (m)	4H	Ether Methylenes	Two diastereotopic protons if rotation is restricted, but typically a complex quartet-like multiplet. Unaffected by d3-labeling.
Ethyl	1.21	Triplet (t)	6H	Ether Methyls	Hz. Unaffected.
C2-	Silent	-	-	Acetyl Methyl	Signal at ~1.30 ppm (d) is absent in the d3 spectrum.

Carbon-13 (¹³C) NMR Spectroscopy

The

¹³C spectrum reveals the direct attachment of deuterium. The C2 carbon signal will be dramatically reduced in intensity and split due to Carbon-Deuterium coupling (

).

Position	Shift (ppm)	Multiplicity	Assignment	Isotope Effect Note
C1	102.5	Singlet (s)	Acetal Carbon	May show slight upfield isotope shift (ppm) and weak broadening.
Ethyl	60.8	Singlet (s)	Ether Methylenes	Standard intensity.
C2	~19.5	Septet (m)	Deuterated Methyl	Diagnostic: Signal intensity drops significantly (loss of NOE). Splits into a septet () due to coupling with 3 deuterons (Hz).
Ethyl	15.3	Singlet (s)	Ether Methyls	Standard intensity.

Synthesis & Preparation Protocol

For research applications requiring high isotopic purity, the synthesis involves the acid-catalyzed protection of Acetaldehyde-d4 (or d3) using anhydrous ethanol.

Reagents

- Precursor: Acetaldehyde-d4 () or Acetaldehyde-d3 ().
- Reactant: Ethanol (Anhydrous, 200 proof).
- Catalyst: p-Toluenesulfonic acid (pTSA) or Calcium Chloride ().
- Solvent/Entrainer: Hexane (optional, for azeotropic water removal).

Workflow Diagram

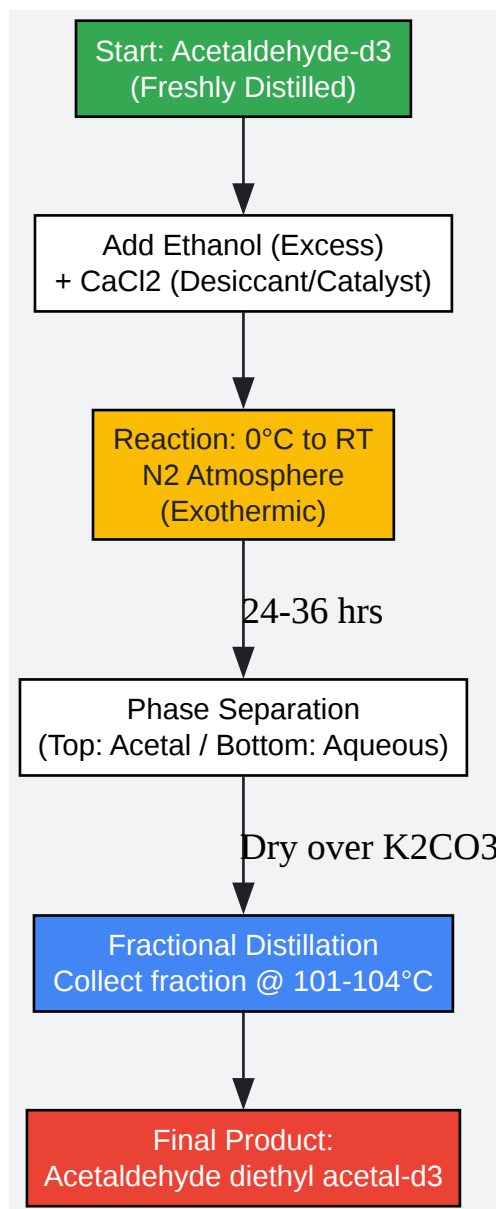

[Click to download full resolution via product page](#)

Figure 2: Synthesis workflow for Acetaldehyde diethyl acetal-d3 via acid-catalyzed acetalization.

Step-by-Step Methodology

- Setup: Place 50g of anhydrous

and 320 mL of anhydrous ethanol in a flask cooled to 0°C.

- Addition: Slowly add 1 mole equivalent of Acetaldehyde-d₃. The reaction is exothermic; addition must be controlled to prevent volatilization of the labeled aldehyde.
- Equilibration: Seal the flask and shake vigorously. Allow to stand for 24 hours. The acts as both a catalyst and a water scavenger to drive the equilibrium forward.
- Workup: The mixture will separate into two layers. Isolate the upper organic layer.
- Purification: Wash the organic layer with water (rapidly, to avoid hydrolysis) and dry over anhydrous .
- Distillation: Perform fractional distillation. Collect the fraction boiling at 101–104°C.

Quality Control & Validation

To ensure the material is suitable for drug metabolism studies, validation must confirm both chemical purity and isotopic enrichment.

Self-Validating Protocol (NMR Check)

- Run
H NMR in .
- Check the 4.65 ppm region:
 - Pass: Sharp singlet (or very slightly broad singlet).
 - Fail (Incomplete Labeling): Presence of a quartet or overlapping multiplet indicates non-deuterated acetaldehyde was present.
- Check the 9.8 ppm region:
 - Fail (Hydrolysis): A signal here indicates free aldehyde (acetal hydrolysis). The sample is degrading and must be redistilled.

Isotopic Enrichment Calculation

Note: The residual doublet at 1.30 ppm represents non-deuterated methyl protons.

Applications in Drug Development

Metabolic Tracking

Acetaldehyde diethyl acetal-d3 is primarily used as a surrogate standard for Acetaldehyde-d3.

Free acetaldehyde is highly volatile (

) and reactive, making it difficult to quantitate in biological matrices.

- Protocol: The acetal is spiked into the plasma/urine sample. Acidic deprotection (in situ) releases the Acetaldehyde-d3 immediately prior to derivatization (e.g., with DNPH) for LC-MS analysis.

Internal Standard (GC-MS)

In headspace GC-MS analysis of residual solvents in pharmaceuticals, the d3-acetal serves as a stable internal standard for the quantification of acetal impurities, correcting for matrix effects and injection variability.

References

- Synthesis & Parent Compound Data
 - Organic Syntheses, Coll. Vol. 1, p. 1 (1941); Vol. 1, p. 5 (1921). "Acetal".[\[1\]\[4\]\[5\]\[3\]\[6\]\[7\]\[8\]\[9\]\[10\]](#) [Link](#)
- NMR Spectral Data (Parent Compound Reference)
 - National Institute of Advanced Industrial Science and Technology (AIST). "SDBS Compounds and Spectral Search: 1,1-Diethoxyethane". [Link](#)
- Isotope Effects in NMR: Berger, S. (1997). Chemical Shift Standards and Impurities. In: S. Braun, H.-O. Kalinowski, S. Berger, 150 and More Basic NMR Experiments. Wiley-VCH.
- General Physical Properties

- PubChem Database. "1,1-Diethoxyethane".^[4] National Center for Biotechnology Information. [Link](#)
- Commercial Availability & CAS Verification
 - Sigma-Aldrich (Merck). "Acetaldehyde diethyl acetal Product Sheet". [Link](#)

Need Custom Synthesis?

BenchChem offers custom synthesis for rare earth carbides and specific isotopic labeling.

Email: info@benchchem.com or [Request Quote Online](#).

Sources

- 1. Acetylacetaldehyde dimethyl acetal(5436-21-5) 1H NMR spectrum [chemicalbook.com]
- 2. prepchem.com [prepchem.com]
- 3. 1,1-Diethoxyethane - Wikipedia [en.wikipedia.org]
- 4. 1,1-Dichloro-2,2-diethoxyethane | C₆H₁₂Cl₂O₂ | CID 12080 - PubChem [pubchem.ncbi.nlm.nih.gov]
- 5. chegg.com [chegg.com]
- 6. acetaldehyde dimethyl acetal [chem.purdue.edu]
- 7. spectrabase.com [spectrabase.com]
- 8. CAS 4819-77-6: 1,1,2-Triethoxyethane | CymitQuimica [cymitquimica.com]
- 9. Bromoacetaldehyde diethyl acetal(2032-35-1) 1H NMR spectrum [chemicalbook.com]
- 10. ez.restek.com [ez.restek.com]
- To cite this document: BenchChem. [Technical Guide: NMR Spectral Analysis & Synthesis of Acetaldehyde Diethyl Acetal-d₃]. BenchChem, [2026]. [Online PDF]. Available at: [https://www.benchchem.com/product/b1147749/docs#technical-guide-nmr-spectral-analysis-synthesis-of-acetaldehyde-diethyl-acetal-d3]

Disclaimer & Data Validity:

The information provided in this document is for Research Use Only (RUO) and is strictly not intended for diagnostic or therapeutic procedures. While BenchChem strives to provide accurate protocols, we make no warranties, express or implied, regarding the fitness of this product for every specific experimental setup.

Technical Support: The protocols provided are for reference purposes. Unsure if this reagent suits your experiment?

Need Industrial/Bulk Grade? [Request Custom Synthesis Quote](#)

BenchChem

Our mission is to be the trusted global source of essential and advanced chemicals, empowering scientists and researchers to drive progress in science and industry.

Contact

Address: 3281 E Guasti Rd
Ontario, CA 91761, United States
Phone: (601) 213-4426
Email: info@benchchem.com

[Contact our Ph.D. Support Team for a compatibility check](#)