

Technical Guide: Cyclophosphamide-d4 vs. Cyclophosphamide-13C6 in LC-MS/MS Bioanalysis

Author: BenchChem Technical Support Team. **Date:** May 2026

Compound of Interest

Compound Name:	Cyclophosphamide-d4
CAS No.:	1178905-08-2
Cat. No.:	B1147816

[Get Quote](#)

Executive Summary

In the quantitative bioanalysis of Cyclophosphamide (CP), the choice between **Cyclophosphamide-d4** (CP-d4) and Cyclophosphamide-13C6 (CP-13C6) is not merely a matter of cost—it is a decision that fundamentally impacts assay linearity, dynamic range, and robustness.

While CP-d4 is a standard, cost-effective option, it introduces two critical sources of analytical error: chromatographic retention time shifts (the "Deuterium Effect") and isobaric interference due to the natural chlorine isotope pattern of the analyte. CP-13C6, though often more expensive, eliminates both issues, providing a "gold standard" for high-precision pharmacokinetics (PK) and therapeutic drug monitoring (TDM).

This guide dissects the physicochemical and spectrometric mechanisms differentiating these two internal standards (IS) and provides a validated framework for selection.

Molecular Architecture & Isotopic Physics

Cyclophosphamide is a nitrogen mustard alkylating agent containing two chlorine atoms.[1] This halogenated structure dictates the isotopic considerations for mass spectrometry.

Feature	Cyclophosphamide-d4	Cyclophosphamide-13C6
Labeling Strategy	Deuterium (H) substitution.[2] Typically on the chloroethyl side chains or the oxazaphosphorine ring (C4/C5).	Carbon-13 (C) substitution. Typically labels the chloroethyl carbons and/or ring carbons.
Mass Shift	+4 Da	+6 Da
Bond Length	C-D bonds are shorter and stronger than C-H bonds.	C-H bonds are chemically identical to C-H in length/polarity.
Lipophilicity	Slightly lower than natural CP (more polar).	Identical to natural CP.
Primary Risk	Retention time shift & Isotopic Overlap.[3]	Cost & Availability.

The Chromatography Challenge: The Deuterium Effect

In Reverse-Phase Liquid Chromatography (RPLC), the separation mechanism relies on hydrophobic interaction. Deuterium (

H) has a lower molar volume and polarizability than Hydrogen (

H), making deuterated molecules slightly less lipophilic.

The Phenomenon[4][5][6][7]

- CP-d4 Behavior: CP-d4 often elutes earlier than natural Cyclophosphamide. The shift typically ranges from 2 to 10 seconds, depending on the column phase and gradient slope.
- CP-13C6 Behavior: Carbon-13 isotopes do not alter lipophilicity. CP-13C6 co-elutes perfectly with the analyte.

The Consequence: Differential Matrix Effects

In complex matrices (plasma, urine), ion suppression zones are narrow and transient.

- If CP elutes at

 min and CP-d4 elutes at

 min, they may exist in different "ionization environments."
- A co-eluting phospholipid causing suppression at 2.50 min might not suppress the IS at 2.45 min.
- Result: The IS fails to normalize the signal variation, leading to inaccurate quantification (high %CV).

The Mass Spectrometry Challenge: The Chlorine Isotope Overlap

This is the most critical technical differentiator. Cyclophosphamide (

) contains two chlorine atoms.[4] Chlorine has two abundant stable isotopes:

Cl (75.8%) and

Cl (24.2%).

The Isotope Pattern

Natural Cyclophosphamide exhibits a distinct "M+2" and "M+4" pattern:

- M+0 (261 m/z): Contains two

 Cl. (Relative Abundance: 100%)

- M+2 (263 m/z): Contains one Cl and one Cl. (Relative Abundance: ~64%)
- M+4 (265 m/z): Contains two Cl. (Relative Abundance: ~10%)

The "Cross-Talk" Mechanism[6]

- CP-d4 (Mass Shift +4): The monoisotopic mass of CP-d4 is M+4 relative to the analyte.
- The Conflict: The M+4 isotope of the natural analyte (containing two Cl atoms) has the exact same mass as the monoisotopic CP-d4.
- Impact: At high concentrations of Cyclophosphamide (e.g., in PK studies), the natural M+4 isotope contributes significant signal to the IS channel.
 - Symptom:[5] The IS peak area increases as analyte concentration increases.
 - Result: Non-linear calibration curves (quadratic fit required) and under-estimation of high concentrations.
- CP-13C6 (Mass Shift +6):
 - The monoisotopic mass is M+6 relative to the analyte.
 - Natural Cyclophosphamide has negligible M+6 abundance.
 - Result: Zero cross-talk. Linear calibration curves.

Visualization: Isotopic Interference Workflow

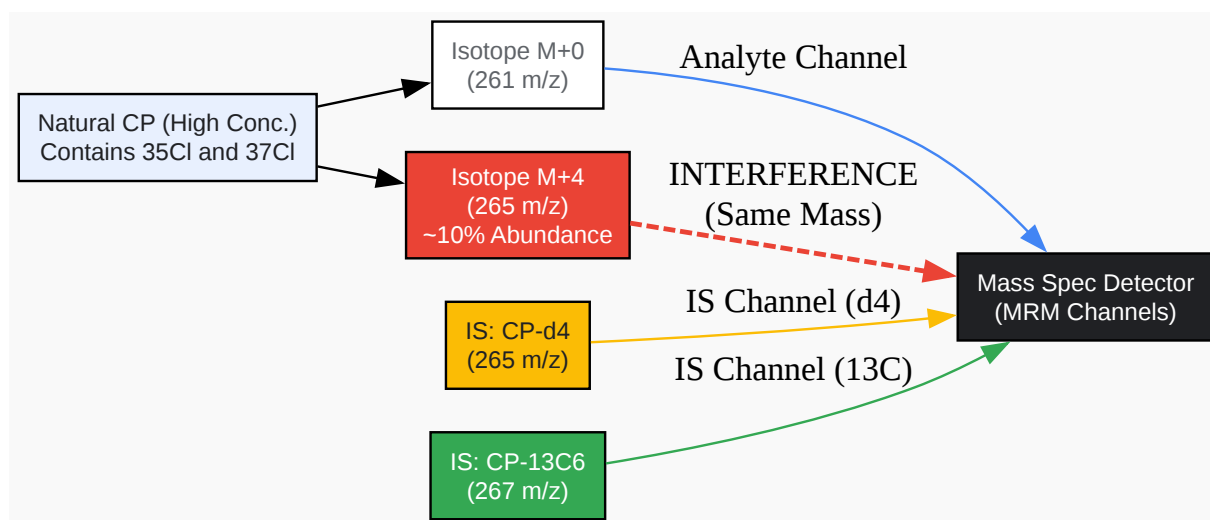

[Click to download full resolution via product page](#)

Caption: The M+4 isotope of natural Cyclophosphamide (derived from two ^{37}Cl atoms) creates isobaric interference in the CP-d4 channel, biasing quantification.

Metabolic Stability & Kinetic Isotope Effect (KIE)

Cyclophosphamide is a prodrug requiring bioactivation via hydroxylation at the C4 position of the oxazaphosphorine ring.

- The Risk with d4: If the CP-d4 is labeled at the C4 position (e.g., 4,4-d2), the Carbon-Deuterium bond is stronger than the Carbon-Hydrogen bond. This makes the IS significantly more resistant to metabolism (primary Kinetic Isotope Effect).
 - In Vitro Studies: You cannot use C4-labeled d4 as a substrate to study metabolic stability; it will yield falsely long half-life data.
 - Bioanalysis:[\[6\]](#)[\[7\]](#)[\[8\]](#)[\[9\]](#) If plasma samples are not properly stabilized (e.g., with semicarbazide) and degradation occurs on the bench, the natural analyte may degrade faster than the C4-labeled IS, leading to over-estimation of drug concentration.
- The Advantage of $^{13}\text{C}_6$: Carbon-13 has no significant kinetic isotope effect. It behaves biochemically identical to the natural drug.

Selection Guide & Experimental Protocol

Decision Matrix

Scenario	Recommended IS	Rationale
High Sensitivity PK (Low LLOQ)	CP-13C6	Eliminates matrix effect variance due to RT shifts.
High Concentration (TDM)	CP-13C6	Avoids M+4 chlorine isotope interference (Cross-talk).
Routine Clinical Monitoring	CP-d4	Acceptable if chromatography separates interferences and cross-talk is mathematically corrected.
Metabolic Stability Studies	CP-13C6	Avoids KIE; ensures IS degrades at same rate as analyte.

Protocol: Validating CP-d4 for Cross-Talk

If budget constraints force the use of CP-d4, you must validate the "Isotopic Contribution" factor:

- Prepare ULOQ Sample: Prepare a sample containing the Analyte at the Upper Limit of Quantification (ULOQ) without Internal Standard.
- Inject: Run this sample using the full LC-MS/MS method.
- Monitor IS Channel: Check the peak area in the transition channel assigned to the IS (e.g., 265 -> 140).
- Calculate Interference:
- Criteria: If Interference > 5% of the typical IS response, the assay is invalid at high concentrations. You must switch to CP-13C6 or reduce the ULOQ.

References

- Ekhart, C., et al. (2007).[7] "Simultaneous quantification of cyclophosphamide and its active metabolite 4-hydroxycyclophosphamide in human plasma by high-performance liquid chromatography coupled with electrospray ionization tandem mass spectrometry (LC-MS/MS)." *Journal of Chromatography B*.
- Wang, S., et al. (2014). "Do deuterium labeled internal standards correct for matrix effects in LC-MS/MS assays?" *Clinica Chimica Acta*.
- Jemal, M., et al. (2013). "Correction for isotopic interferences between analyte and internal standard in quantitative mass spectrometry by a nonlinear calibration function." *Rapid Communications in Mass Spectrometry*.
- Harahap, Y., et al. (2022).[10] "Development and validation of a UPLC-MS/MS method with volumetric absorptive microsampling to quantitate cyclophosphamide and 4-hydroxycyclophosphamide." *Frontiers in Pharmacology*.
- Nielsen, L.S., et al. (2012). "13C labelled internal standards--a solution to minimize ion suppression effects in liquid chromatography-tandem mass spectrometry analyses of drugs in biological samples?" *Journal of Chromatography B*.

Need Custom Synthesis?

BenchChem offers custom synthesis for rare earth carbides and specific isotopic labeling.

Email: info@benchchem.com or [Request Quote Online](#).

Sources

- [1. Cyclophosphamide | C7H15Cl2N2O2P | CID 2907 - PubChem \[pubchem.ncbi.nlm.nih.gov\]](#)
- [2. researchgate.net \[researchgate.net\]](#)
- [3. Retention time shift analysis and correction in chemical isotope labeling liquid chromatography/mass spectrometry for metabolome analysis - PubMed \[pubmed.ncbi.nlm.nih.gov\]](#)
- [4. accessdata.fda.gov \[accessdata.fda.gov\]](#)

- 5. Correction for isotopic interferences between analyte and internal standard in quantitative mass spectrometry by a nonlinear calibration function - PubMed [pubmed.ncbi.nlm.nih.gov]
- 6. Reliable procedures to evaluate and repair crosstalk for bioanalytical MS/MS assays - PubMed [pubmed.ncbi.nlm.nih.gov]
- 7. Simultaneous quantification of cyclophosphamide and its active metabolite 4-hydroxycyclophosphamide in human plasma by high-performance liquid chromatography coupled with electrospray ionization tandem mass spectrometry (LC-MS/MS) - PubMed [pubmed.ncbi.nlm.nih.gov]
- 8. Phenotyping Study of Cyclophosphamide 4-Hydroxylation in Malay Cancer Patients - PMC [pmc.ncbi.nlm.nih.gov]
- 9. Kinetic isotope effects in hydroxylation reactions effected by cytochrome P450 compounds I implicate multiple electrophilic oxidants for P450-catalyzed oxidations - PubMed [pubmed.ncbi.nlm.nih.gov]
- 10. Mitigating analyte to stable isotope labelled internal standard cross-signal contribution in quantitative liquid chromatography-tandem mass spectrometry - PMC [pmc.ncbi.nlm.nih.gov]
- To cite this document: BenchChem. [Technical Guide: Cyclophosphamide-d4 vs. Cyclophosphamide-13C6 in LC-MS/MS Bioanalysis]. BenchChem, [2026]. [Online PDF]. Available at: [<https://www.benchchem.com/product/b1147816/docs#technical-guide-cyclophosphamide-d4-vs-cyclophosphamide-13c6-in-lc-ms-ms-bioanalysis>]

Disclaimer & Data Validity:

The information provided in this document is for Research Use Only (RUO) and is strictly not intended for diagnostic or therapeutic procedures. While BenchChem strives to provide accurate protocols, we make no warranties, express or implied, regarding the fitness of this product for every specific experimental setup.

Technical Support: The protocols provided are for reference purposes. Unsure if this reagent suits your experiment?

Need Industrial/Bulk Grade? [Request Custom Synthesis Quote](#)

BenchChem

Our mission is to be the trusted global source of essential and advanced chemicals, empowering scientists and researchers to drive progress in science and industry.

Contact

Address: 3281 E Guasti Rd

Ontario, CA 91761, United States

Phone: (601) 213-4426

Email: info@benchchem.com

[Contact our Ph.D. Support Team for a compatibility check](#)