

Application Notes and Protocols: Fluoropolymers in Low Refractive Index Materials

Author: BenchChem Technical Support Team. **Date:** May 2026

Compound of Interest

Compound Name: Difluoro(2,3,4-trifluorophenyl)methyl prop-2-enoate

CAS No.: 153614-61-0

Cat. No.: B1146513

[Get Quote](#)

For Researchers, Scientists, and Drug Development Professionals

Introduction

Fluoropolymers are a class of polymers containing fluorine atoms that exhibit a unique combination of properties, making them highly valuable for advanced material applications. Due to the high electronegativity and low atomic polarizability of fluorine, these materials possess exceptionally low refractive indices.[1][2] This characteristic, combined with their inherent chemical inertness, hydrophobicity, and thermal stability, makes them ideal candidates for the development of low refractive index materials for a variety of optical and biomedical applications.[3][4]

This document provides an overview of the application of fluoropolymers in low refractive index materials, with a focus on their use in antireflective coatings and optical waveguides. Detailed experimental protocols for the synthesis and characterization of these materials are also provided.

Applications of Low Refractive Index Fluoropolymers

The unique optical properties of fluoropolymers make them suitable for a range of applications:

- **Antireflective (AR) Coatings:** Fluoropolymer-based AR coatings are used on optical lenses, displays, and solar cells to reduce surface reflection and improve light transmission.[3][5] These coatings are often constructed as multilayer films with alternating high and low refractive index layers to achieve broadband antireflection.[1][4]
- **Optical Waveguides and Fibers:** In optical communications, fluoropolymers are used as cladding materials for optical fibers and in the fabrication of polymer optical waveguides.[6][7] Their low refractive index is crucial for confining light within the core of the waveguide.[6] Amorphous fluoropolymers like CYTOP™ and Teflon™ AF are particularly noted for their high optical transparency and are used in these applications.[7][8][9]
- **Biomedical and Microfluidic Devices:** The low surface energy and biocompatibility of some fluoropolymers make them suitable for use in biomedical devices and microfluidic chips where minimizing non-specific protein adsorption and controlling fluid flow are important. Their optical transparency is also advantageous for imaging and sensing applications.
- **Coatings for Electronics:** Transparent fluoropolymer coatings can protect sensitive electronic components from moisture and corrosion while allowing for optimal light transmission, which is critical for displays and sensors.[9]

Properties of Common Low Refractive Index Fluoropolymers

A variety of fluoropolymers are utilized for their low refractive index properties. The refractive index is dependent on the fluorine content; a higher volume percentage of fluorine generally leads to a lower refractive index.[3][4]

Fluoropolymer/Copolymer	Refractive Index (n) at 633 nm	Key Features	Applications
Poly(1H,1H,2H,2H-perfluorodecyl acrylate) (pPFDA)	1.378	Semicrystalline, hydrophobic	Optical coatings
p(PFDA-co-VP) (copolymer with N-vinylpyrrolidone)	~1.365	Amorphous, transparent, hydrophobic	Flexible optical thin films, AR coatings
Teflon™ AF (Amorphous Fluoropolymer)	< 1.31	Amorphous, soluble in select solvents, high gas permeability	Optical lenses, fiber optic cladding, AR coatings
CYTOP™ (Amorphous Fluoropolymer)	~1.34	Amorphous, high optical transparency, soluble in fluorinated solvents	AR coatings, optical waveguides, protective coatings
Dyneon™ THV™	Varies with composition	Melt-processible, transparent	Flexible films and coatings

Experimental Protocols

Protocol 1: Synthesis of a Low Refractive Index Fluoropolymer Thin Film via Initiated Chemical Vapor Deposition (iCVD)

This protocol describes the synthesis of a p(PFDA-co-VP) copolymer thin film, a material with a low refractive index and high transparency.^{[1][10]}

Workflow for iCVD Synthesis of p(PFDA-co-VP) Thin Films

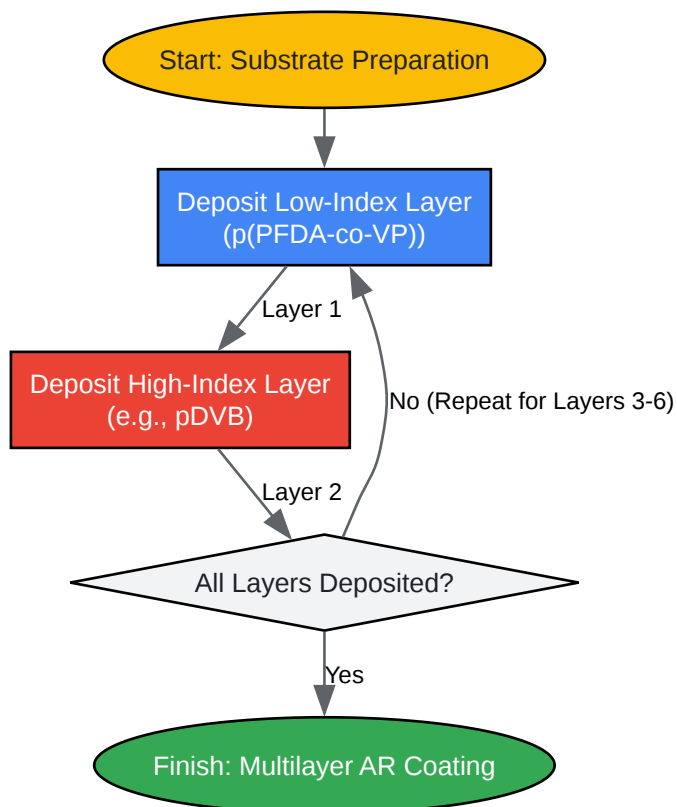
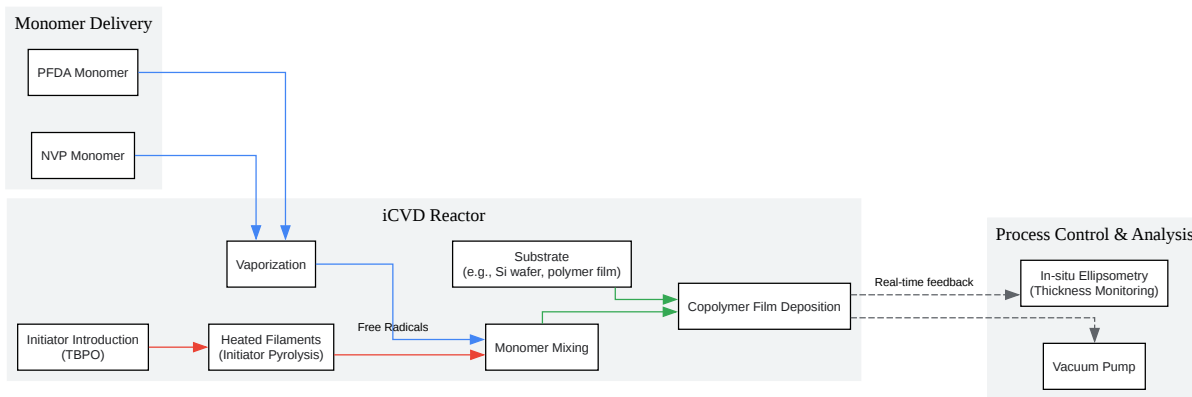

[Click to download full resolution via product page](#)

Need Custom Synthesis?

BenchChem offers custom synthesis for rare earth carbides and specific isotopic labeling.

Email: info@benchchem.com or [Request Quote Online](#).

References

- [1. pubs.acs.org \[pubs.acs.org\]](https://pubs.acs.org)
- [2. researchgate.net \[researchgate.net\]](https://researchgate.net)
- [3. US7323514B2 - Low refractive index fluoropolymer coating compositions for use in antireflective polymer films - Google Patents \[patents.google.com\]](#)
- [4. WO2006073785A1 - Low refractive index fluoropolymer compositions having improved coating and durability properties - Google Patents \[patents.google.com\]](#)
- [5. pubs.acs.org \[pubs.acs.org\]](https://pubs.acs.org)
- [6. mdpi.com \[mdpi.com\]](https://mdpi.com)
- [7. chromistechnologies.com \[chromistechnologies.com\]](https://chromistechnologies.com)
- [8. specialchem.com \[specialchem.com\]](https://specialchem.com)
- [9. agcchem.com \[agcchem.com\]](https://agcchem.com)
- [10. Control of Fluoropolymer Crystallinity for Flexible, Transparent Optical Thin Films with Low Refractive Indexes - PMC \[pmc.ncbi.nlm.nih.gov\]](#)
- To cite this document: BenchChem. [Application Notes and Protocols: Fluoropolymers in Low Refractive Index Materials]. BenchChem, [2026]. [Online PDF]. Available at: [\[https://www.benchchem.com/product/b1146513/docs#application-notes-and-protocols-fluoropolymers-in-low-refractive-index-materials\]](https://www.benchchem.com/product/b1146513/docs#application-notes-and-protocols-fluoropolymers-in-low-refractive-index-materials)

Disclaimer & Data Validity:

The information provided in this document is for Research Use Only (RUO) and is strictly not intended for diagnostic or therapeutic procedures. While BenchChem strives to provide accurate protocols, we make no warranties, express or implied, regarding the fitness of this product for every specific experimental setup.

Technical Support: The protocols provided are for reference purposes. Unsure if this reagent suits your experiment?

Need Industrial/Bulk Grade? [Request Custom Synthesis Quote](#)

BenchChem

Our mission is to be the trusted global source of essential and advanced chemicals, empowering scientists and researchers to drive progress in science and industry.

Contact

Address: 3281 E Guasti Rd
Ontario, CA 91761, United States
Phone: (601) 213-4426
Email: info@benchchem.com

[Contact our Ph.D. Support Team for a compatibility check](#)