

# Technical Support Center: Phenylene Bis(benzoates) & Alkyl Chain Engineering

**Author:** BenchChem Technical Support Team. **Date:** April 2026

## Compound of Interest

Compound Name: 1,2-phenylene bis(4-(octyloxy)benzoate)

CAS No.: 1369505-05-4

Cat. No.: B1145740

[Get Quote](#)

Topic: Impact of Alkyl Chain Length on Phenylene Bis(benzoates) Properties Document ID: PBB-LC-004 Status: Active Audience: Synthetic Chemists, Materials Scientists

## Core Technical Overview

Phenylene bis(benzoates) are a class of calamitic (rod-like) liquid crystals where a central phenylene ring is ester-linked to two benzoate wings. The terminal alkyl chains (

) attached to these wings act as the primary "tuning knobs" for phase behavior.

The Critical Rule: The length of the alkyl chain (

) dictates the delicate balance between the rigid core's anisotropic interactions and the flexible tail's entropic disorder.

- Short Chains ( ): Often result in high-melting crystalline solids with no mesophase or monotropic (metastable) phases.

- Medium Chains ( ): Typically favor Nematic ( ) phases.
- Long Chains ( ): Stabilize Smectic ( ) phases (layered ordering) due to increased van der Waals lateral interdigitation.

## Troubleshooting Guides

### Module A: Synthesis & Purification Anomalies

Issue: Low yield or inability to crystallize the final product.

Symptom	Probable Cause (Chain Length Related)	Corrective Action	Mechanism
Product oils out during recrystallization	Long Chains ( ): High conformational flexibility lowers the melting point, making crystallization difficult in standard ethanol/ethyl acetate mixtures.	Switch to Hexane/Ethanol (1:5) or Acetone at -20°C. Induce nucleation by scratching or seeding.	Long alkyl chains increase solubility in non-polar solvents and suppress crystal lattice formation energy.
Precipitate is insoluble in hot ethanol	Short Chains ( ): High lattice energy and low entropic contribution from chains reduce solubility.	Use DMF or Toluene for recrystallization.	Short chains allow efficient packing of the rigid aromatic cores, significantly increasing the energy required to solvate the crystal.
"Double Melting" observed on TLC/Melting Point	Polymorphism ( ): Common in phenylene bis(benzoates).	Do not discard. Verify via DSC.[1] The first "melt" may be a Crystal Smectic/Nematic transition, not an impurity.	Liquid crystals exhibit mesophases between the solid and isotropic liquid states.[2][3] Visual melting is often the transition.

## Module B: Phase Behavior & Characterization

Issue: DSC data does not match expected transition temperatures.

Q: Why do my transition temperatures oscillate between homologues? A: You are observing the Odd-Even Effect.

- Diagnosis: Plot the Clearing Point (

or

) vs. Carbon Number (

).

- Pattern: Derivatives with Even

(C4, C6, C8) typically exhibit higher transition temperatures and entropies than Odd

(C3, C5, C7).

- Root Cause: The terminal methyl group's orientation relative to the molecular long axis alternates.[4] For even chains, the methyl group enhances the shape anisotropy (length-to-width ratio), stabilizing the mesophase. For odd chains, the methyl group lies off-axis, introducing steric perturbation that destabilizes the phase order [1, 2].

Q: My C12 homologue shows a texture under POM that doesn't flow like the C6 homologue.

Why? A: The phase has likely shifted from Nematic to Smectic.

- C6 (Nematic): Thread-like or Schlieren texture. Low viscosity.
- C12 (Smectic): Focal-conic fan texture. Higher viscosity.[5]
- Verification: Press the cover slip. Nematic phases "flash" and flow easily; Smectic phases are more viscous and the texture defects (fans) may deform but persist.

## Experimental Protocols

### Protocol 1: Synthesis of 1,4-Phenylene Bis(4-alkoxybenzoates)

Standard Steglich Esterification adapted for variable chain lengths.

Reagents:

- Hydroquinone (Central Core)
- 4-Alkoxybenzoic acid (2.2 equiv, Tail source)

- DCC (Dicyclohexylcarbodiimide, Coupling agent)
- DMAP (Dimethylaminopyridine, Catalyst)
- Dichloromethane (DCM, Solvent)

#### Workflow:

- Dissolution: Dissolve 10 mmol Hydroquinone and 22 mmol 4-Alkoxybenzoic acid in 50 mL dry DCM.
- Catalyst: Add 10 mol% DMAP.
- Coupling: Cool to 0°C. Add 24 mmol DCC dissolved in DCM dropwise over 30 mins.
  - Note: For Long Chains ( ), ensure the acid is fully solubilized before DCC addition; mild heating (30°C) may be required before cooling.
- Reaction: Stir at RT for 24h. DCU (urea byproduct) will precipitate.
- Filtration: Filter off DCU.
- Workup: Wash filtrate with 0.5N HCl, then sat. , then Brine. Dry over .
- Purification (Chain Dependent):
  - : Recrystallize from Ethanol/Ethyl Acetate.
  - : Recrystallize from Acetone or Hexane/Ethanol.

## Visualization: Synthesis Logic Flow

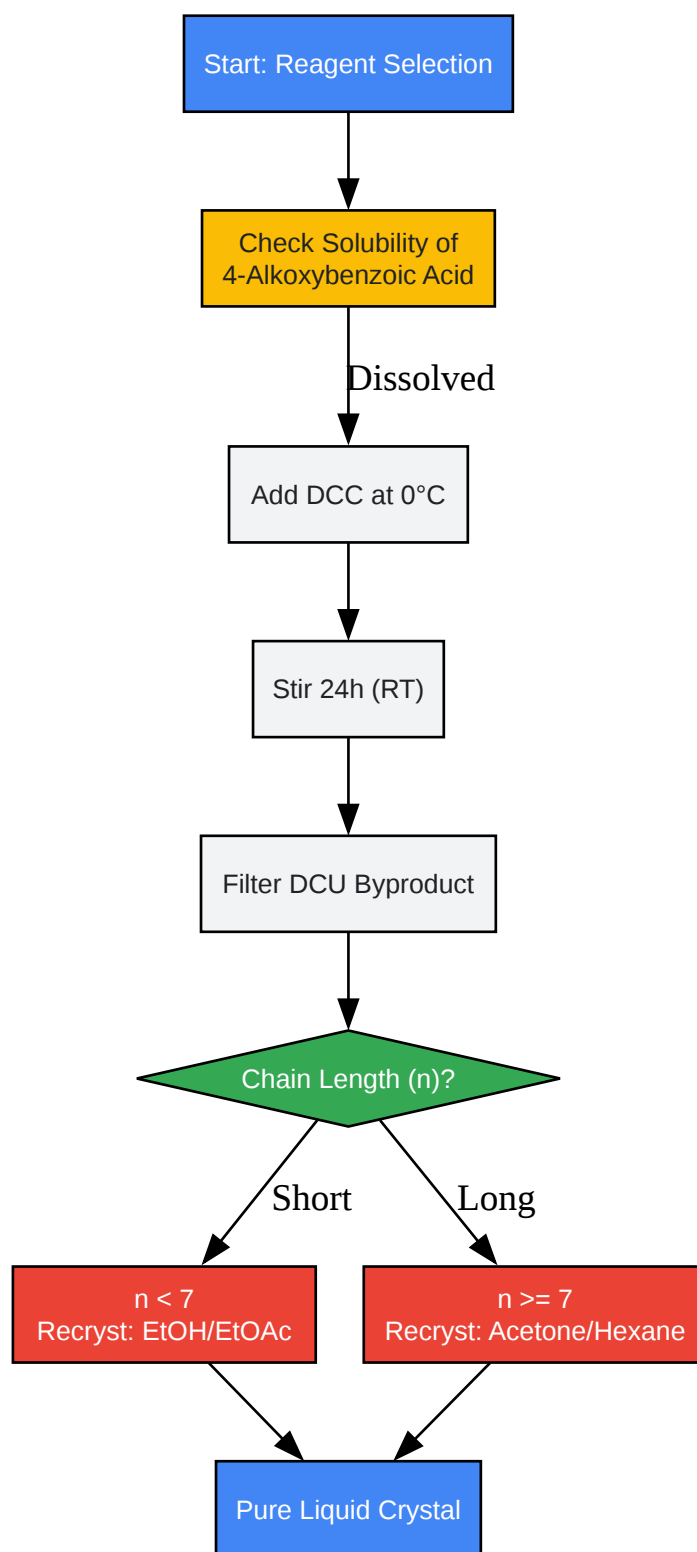

[Click to download full resolution via product page](#)

Caption: Decision tree for the synthesis and purification of phenylene bis(benzoates) based on alkyl chain length.

## Comparative Data: Chain Length Effects

The following table summarizes the general trends observed in 1,4-phenylene bis(4-n-alkoxybenzoates). Note that specific temperatures vary by exact substitution pattern (e.g., 1,3-phenylene vs 1,4-phenylene) [3, 4].

Alkyl Chain ( )	Primary Phase	Melting Point Trend	Clearing Point ( )	Odd-Even Effect
Short (1-3)	Crystalline / Monotropic	High	Low / Virtual	Weak
Medium (4-7)	Nematic (N)	Decreasing	Moderate	Strong (Even > Odd)
Long (8-12)	Smectic (SmC/SmA) + Nematic	Low / Plateau	High	Moderate
Very Long (14+)	Smectic Only	Low	High	Weak

## Visualization: Phase Behavior Logic

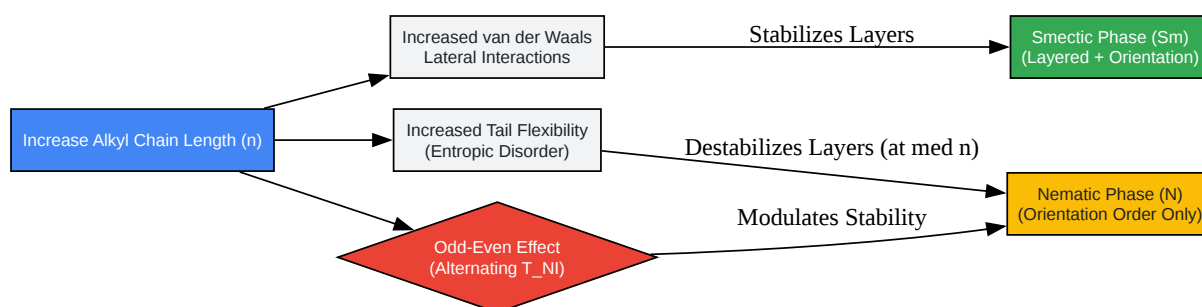

[Click to download full resolution via product page](#)

Caption: Mechanistic flow showing how chain length elongation drives the transition from Nematic to Smectic phases via competing intermolecular forces.

## FAQ: Application Suitability

Q: I need a room-temperature liquid crystal. Which chain length should I target? A: Pure phenylene bis(benzoates) rarely exhibit room-temperature mesophases due to high melting points (

C).

- Strategy: You must create a Eutectic Mixture. Mix homologues of different chain lengths (e.g., mix and in a 50:50 ratio). This disrupts the crystal lattice, lowering the melting point significantly while maintaining liquid crystalline character [5].

Q: How does the central core substitution (1,3- vs 1,4-phenylene) affect the chain length requirement? A:

- 1,4-Phenylene (Linear): Highly symmetric. Requires shorter chains ( ) to induce LC phases. Favors Nematic.
- 1,3-Phenylene (Bent): The bent core reduces linearity. These often require longer chains or specific lateral substituents to exhibit mesophases (often Smectic C due to the bent shape) [1, 6].

## References

- Mesomorphic behaviour of 1,3-phenylene bis[4-(4-alkoxyphenyliminomethyl)benzoates]. Liquid Crystals.
- The Influence of Alkyl Chain Length on Liquid Crystal Phases. BenchChem.[4]
- Effect of Alkyl Chain Length on the Phase Situation of Glass-Forming Liquid Crystals. MDPI / ResearchGate.

- Molecular Structure and Liquid Crystallinity. Phenylene Bis(alkoxybenzoates). Journal of Organic Chemistry.
- Effect of molecular structure on the phase behaviour of some liquid crystalline compounds and their mixtures. ResearchGate.[1]
- Mesomorphic Properties of 1,3-phenylene bis(4-alkoxybenzoates). Bulletin of the Chemical Society of Japan.

### Need Custom Synthesis?

BenchChem offers custom synthesis for rare earth carbides and specific isotopic labeling.

Email: [info@benchchem.com](mailto:info@benchchem.com) or [Request Quote Online](#).

## Sources

- [1. researchgate.net \[researchgate.net\]](#)
- [2. mdpi.com \[mdpi.com\]](#)
- [3. researchgate.net \[researchgate.net\]](#)
- [4. pdf.benchchem.com \[pdf.benchchem.com\]](#)
- [5. researchgate.net \[researchgate.net\]](#)
- To cite this document: BenchChem. [Technical Support Center: Phenylene Bis(benzoates) & Alkyl Chain Engineering]. BenchChem, [2026]. [Online PDF]. Available at: [\[https://www.benchchem.com/product/b1145740/docs#technical-support-center-phenylene-bis-benzoates-alkyl-chain-engineering\]](https://www.benchchem.com/product/b1145740/docs#technical-support-center-phenylene-bis-benzoates-alkyl-chain-engineering)

---

### Disclaimer & Data Validity:

The information provided in this document is for Research Use Only (RUO) and is strictly not intended for diagnostic or therapeutic procedures. While BenchChem strives to provide accurate protocols, we make no warranties, express or implied, regarding the fitness of this product for every specific experimental setup.

**Technical Support:** The protocols provided are for reference purposes. Unsure if this reagent suits your experiment?

**Need Industrial/Bulk Grade?** [Request Custom Synthesis Quote](#)

## BenchChem

Our mission is to be the trusted global source of essential and advanced chemicals, empowering scientists and researchers to drive progress in science and industry.

### Contact

Address: 3281 E Guasti Rd  
Ontario, CA 91761, United States  
Phone: (601) 213-4426  
Email: [info@benchchem.com](mailto:info@benchchem.com)

[Contact our Ph.D. Support Team for a compatibility check](#)