

Technical Support Center: GC-MS

Troubleshooting for 4-Fluoroanisole Analysis

Author: BenchChem Technical Support Team. **Date:** April 2026

Compound of Interest

Compound Name: 4-Fluoroanisole-2,3,5,6-d4

CAS No.: 1219802-94-4

Cat. No.: B1145549

[Get Quote](#)

Welcome to the Technical Support Center. Analyzing low-molecular-weight, volatile halogenated compounds like 4-fluoroanisole (MW ~126.13 g/mol)^[1] via Gas Chromatography-Mass Spectrometry (GC-MS) requires pristine system conditions. Because 4-fluoroanisole elutes early and produces low-mass fragments, it is highly susceptible to interference from system contamination, carrier gas impurities, and column bleed.

This guide provides field-proven, self-validating workflows to diagnose, isolate, and eliminate background noise in your GC-MS system.

Part 1: Diagnostic Workflow

Before altering method parameters or replacing consumables, use the mass spectrometer as a diagnostic tool to isolate the source of the noise.

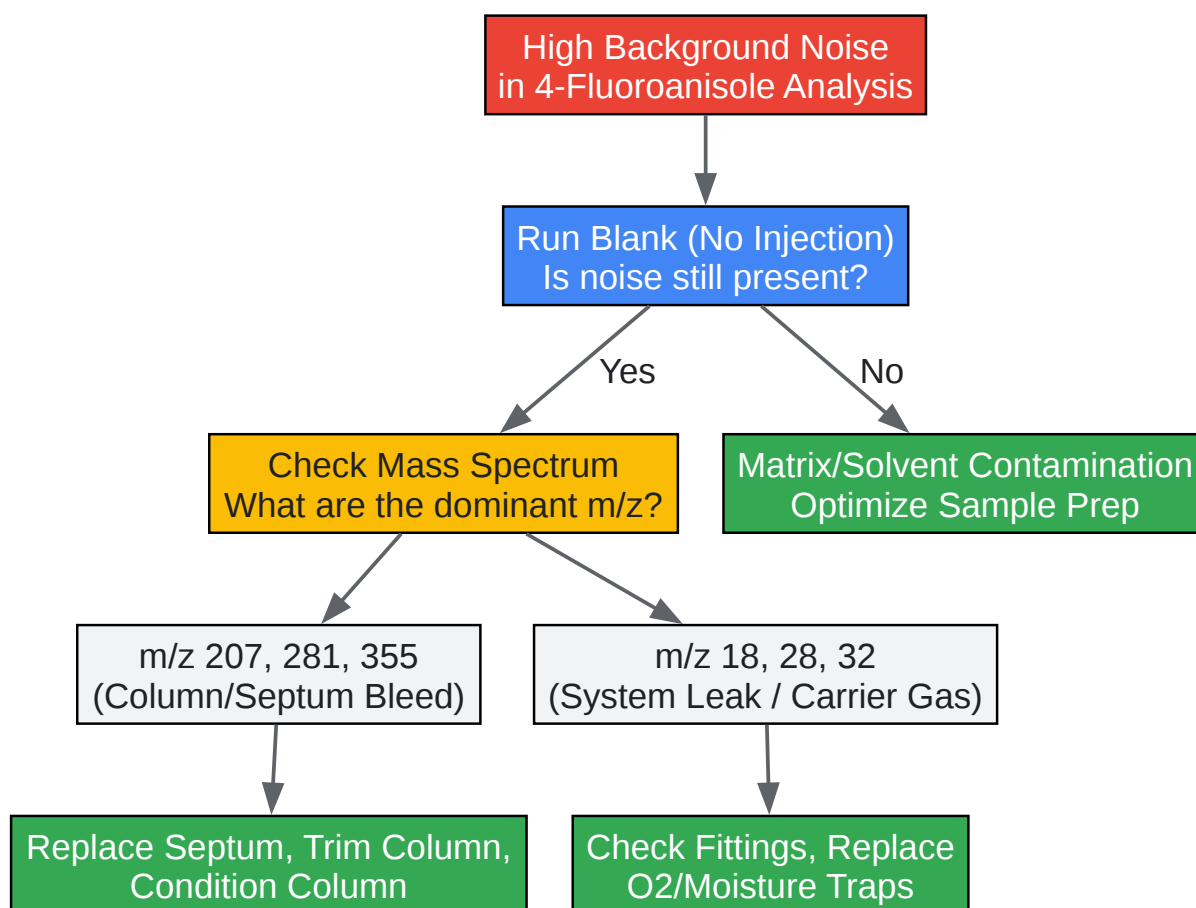

[Click to download full resolution via product page](#)

Diagnostic workflow for isolating GC-MS background noise sources.

Part 2: Troubleshooting Guide & FAQs

Q1: My chromatogram shows a high, noisy baseline during the elution window of 4-fluoroanisole. How do I determine if this is column bleed, a system leak, or matrix interference?

A: By examining the background mass spectrum during a blank run, you can identify the root cause based on specific m/z signatures.

- m/z 207, 281, 355: These are cyclic siloxanes, indicating degradation of the polysiloxane stationary phase (column bleed) or the inlet septum[2].
- m/z 18, 28, 32: These correspond to H₂O, N₂, and O₂, respectively. Their presence indicates an active atmospheric leak or exhausted carrier gas traps.

- Causality: Column bleed is not just "normal wear." Trace oxygen in the carrier gas acts as a catalyst at high temperatures, irreversibly cleaving the polymer backbone of the stationary phase[3]. This releases siloxanes into the MS, raising the baseline and masking the m/z 126 target ion of 4-fluoroanisole.

Q2: How can I optimize the MS acquisition parameters to specifically reduce noise for 4-fluoroanisole? A: Switch your acquisition from Full Scan to Selected Ion Monitoring (SIM) mode.

- Causality: In Full Scan mode, the quadrupole scans a wide mass range, spending only a fraction of a millisecond on each mass, which captures excessive background noise. In SIM mode, the quadrupole acts as a mass filter locked onto specific target ions (e.g., m/z 126, 83, 111)[1]. By increasing the dwell time to 50–100 ms per ion, the detector collects more of the target ions while completely ignoring background siloxanes or matrix ions[4]. This dramatically improves the signal-to-noise (S/N) ratio. Additionally, tuning the repeller and pusher voltages specifically for the lower mass range (m/z 50–150) can further enhance target ion abundance[5].

Q3: My background noise is extremely high at the very beginning of the run, right where 4-fluoroanisole is supposed to elute. What is causing this? A: 4-Fluoroanisole is a highly volatile compound that elutes early in the chromatographic run. If your background noise is localized to the beginning of the run, you are likely observing solvent tailing or the MS filament turning on too early.

- Causality: When a liquid sample is injected, the solvent expands massively in the inlet. If the MS filament is activated before this solvent volume has fully cleared the ion source, the solvent molecules will be ionized, saturating the detector and creating a massive, noisy baseline.
- Solution: Implement a strict Solvent Delay. The MS filament must remain off until the solvent peak has completely passed.

Part 3: Self-Validating Experimental Protocols

Protocol A: System Leak Check & Column Conditioning

Objective: Ensure an oxygen-free environment before thermal conditioning to prevent irreversible column damage.

Step 1: Air/Water Check (Validation Step)

- Set the GC oven to 40°C and ensure carrier gas flow is active.
- Turn on the MS filament and monitor m/z 18 (H₂O), 28 (N₂), and 32 (O₂).
- Validation Criteria: The abundance of m/z 28 must be less than 10% of m/z 18. The abundance of m/z 32 must be approximately 25% of m/z 28.
- Stop-Gate: If m/z 28 > m/z 18, an active air leak is present. Do not proceed to heating. Check the inlet nut, MS transfer line nut, and gas traps.

Step 2: Column Trimming

- Once the leak check passes, cool the inlet and oven.
- Remove 10–20 cm from the inlet end of the column using a ceramic scoring wafer. Inspect the cut with a magnifier to ensure it is perfectly straight (90°). This removes non-volatile matrix residues and active sites that catalyze stationary phase breakdown.

Step 3: Thermal Conditioning

- Set the carrier gas flow to 1.2 mL/min (Helium).
- Program the GC oven to ramp at 10°C/min to 20°C below the column's maximum specified temperature.
- Hold at the maximum temperature for 2 hours. Monitor the Total Ion Chromatogram (TIC); the baseline should initially rise and then steadily drop to a flat, stable level.

Protocol B: SIM Method Setup for 4-Fluoroanisole

Objective: Maximize sensitivity and eliminate background noise by filtering out non-target ions.

Step 1: Full Scan Confirmation

- Inject a high-concentration standard (e.g., 10 ppm) of 4-fluoroanisole in Full Scan mode (m/z 40–200).
- Identify the exact retention time (RT) and confirm the fragmentation pattern (m/z 126, 111, 83)[1].

Step 2: SIM Group Configuration

- Create a SIM group centered around the RT (e.g., RT ± 1.5 minutes).
- Input the target ions (See Table 1).
- Set the dwell time to 50 ms per ion to ensure at least 15 scans across the chromatographic peak.

Part 4: Quantitative Data Summaries

Table 1: 4-Fluoroanisole SIM Parameters & Ion Assignments

Parameter	Value	Rationale
Quantifier Ion	m/z 126	Molecular ion (M+), highest abundance, used for exact quantitation[1].
Qualifier Ion 1	m/z 83	Major fragment (loss of CH ₃ and CO), used for confirmation[1].
Qualifier Ion 2	m/z 111	Fragment (loss of CH ₃), used for structural verification[1].
Dwell Time	50 ms	Ensures >15 data points across the narrow peak of a volatile compound.

Table 2: Diagnostic Background Ions in GC-MS

m/z Value	Source / Contaminant	Corrective Action
18, 28, 32	H ₂ O, N ₂ , O ₂ (System leak or exhausted traps)	Check inlet fittings; replace carrier gas traps.
44	CO ₂ (Air leak or degrading Vespel ferrules)	Retighten MS transfer line nut after thermal cycling.
207, 281, 355	Cyclic siloxanes (Septum or column bleed)	Replace septum[2]; trim and condition the column.

References

- [4-Fluoroanisole | C7H7FO | CID 9987 - PubChem - nih.gov](#) - 1
- [MS TIP No. 12 - Elimination of Memory Peaks and GC Background Noise - sisweb.com](#) - 2
- [Beware of GC Column Bleed - agilent.com](#) - 3
- [Scan Mode vs SIM \(Selected Ion Monitoring\) in GC-MS - shimadzu.com](#) - 4
- [Optimizing GC-MS Methods - chromatographyonline.com](#) - 5

Need Custom Synthesis?

BenchChem offers custom synthesis for rare earth carbides and specific isotopic labeling.

Email: info@benchchem.com or [Request Quote Online](#).

Sources

- [1. 4-Fluoroanisole | C7H7FO | CID 9987 - PubChem \[pubchem.ncbi.nlm.nih.gov\]](#)
- [2. MS Tip - Elimination of Memory Peaks and GC Background Noise \[sisweb.com\]](#)
- [3. agilent.com \[agilent.com\]](#)
- [4. Scan Mode vs SIM \(Selected Ion Monitoring\) in GC-MS | Shimadzu \[shimadzu.com\]](#)
- [5. chromatographyonline.com \[chromatographyonline.com\]](#)

- To cite this document: BenchChem. [Technical Support Center: GC-MS Troubleshooting for 4-Fluoroanisole Analysis]. BenchChem, [2026]. [Online PDF]. Available at: [<https://www.benchchem.com/product/b1145549/docs#technical-support-center-gc-ms-troubleshooting-for-4-fluoroanisole-analysis>]

Disclaimer & Data Validity:

The information provided in this document is for Research Use Only (RUO) and is strictly not intended for diagnostic or therapeutic procedures. While BenchChem strives to provide accurate protocols, we make no warranties, express or implied, regarding the fitness of this product for every specific experimental setup.

Technical Support: The protocols provided are for reference purposes. Unsure if this reagent suits your experiment?

Need Industrial/Bulk Grade? [Request Custom Synthesis Quote](#)

BenchChem

Our mission is to be the trusted global source of essential and advanced chemicals, empowering scientists and researchers to drive progress in science and industry.

Contact

Address: 3281 E Guasti Rd
Ontario, CA 91761, United States
Phone: (601) 213-4426
Email: info@benchchem.com

[Contact our Ph.D. Support Team for a compatibility check](#)