

Comparative Analytical Guide: Quantifying 5-Dehydroxy (3S)-Atorvastatin Impurities

Author: BenchChem Technical Support Team. **Date:** February 2026

Compound of Interest

Compound Name: 5-Dehydroxy (3S)-Atorvastatin

CAS No.: 887196-26-1

Cat. No.: B1145637

[Get Quote](#)

Executive Summary

Objective: To provide a technical comparison between standard Pharmacopeial HPLC-UV methods and optimized UHPLC-MS/MS workflows for the quantification of **5-Dehydroxy (3S)-Atorvastatin**, a critical process-related impurity and degradant.

Audience: Analytical Chemists, QC Managers, and CMC Regulatory Specialists.

The Challenge: **5-Dehydroxy (3S)-Atorvastatin** represents a unique analytical challenge. Structurally similar to the parent API (Atorvastatin Calcium) but lacking the hydroxyl group at the C5 position, it exhibits similar lipophilicity and retention characteristics on standard C18 columns. Furthermore, distinguishing the (3S) stereochemistry from other potential isomers requires high-resolution separation or specific mass spectral transitions.

Part 1: The Target Analyte & Formation Mechanism

Understanding the formation of the impurity is the first step in controlling it. **5-Dehydroxy (3S)-Atorvastatin** is typically formed under acidic conditions or via reductive pathways during the synthesis of the pyrrole ring or subsequent protection/deprotection steps.

Chemical Context

- Parent Molecule: Atorvastatin (3R, 5R configuration).^{[1][2][3][4]}

- Impurity: **5-Dehydroxy (3S)-Atorvastatin**.^[5]
- Criticality: Classified as a specified impurity under ICH Q3A(R2). Its suppression is critical for API stability and safety profiles.

Degradation Pathway Visualization

The following diagram illustrates the simplified formation pathway and the structural relationship between the parent and the target impurity.

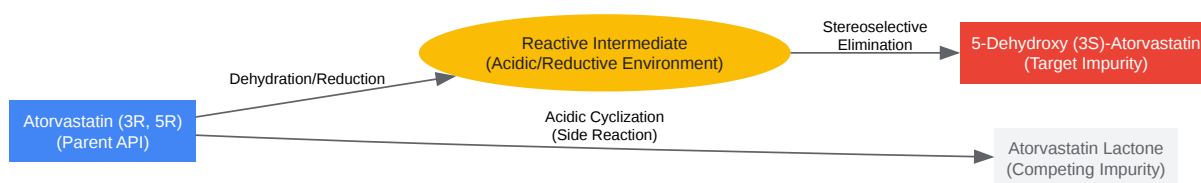

[Click to download full resolution via product page](#)

Figure 1: Simplified formation pathway of **5-Dehydroxy (3S)-Atorvastatin** relative to common lactone formation.

Part 2: Method Comparison (HPLC-UV vs. UHPLC-MS/MS)

While USP monographs typically rely on HPLC-UV for related substances, the detection of **5-Dehydroxy (3S)-Atorvastatin** at trace levels (<0.05%) often pushes the limits of UV detection due to baseline noise and matrix interference.

Comparative Performance Matrix

Feature	Method A: Standard HPLC-UV (USP Modified)	Method B: Optimized UHPLC-MS/MS (Recommended)
Detection Principle	UV Absorbance @ 244 nm	Electrospray Ionization (ESI+) MRM
Sensitivity (LOQ)	~0.05% (Limit of Quantification)	0.005% (Trace Level)
Selectivity	Moderate (Relies on Retention Time)	High (Mass + Retention Time)
Run Time	45–60 Minutes	8–12 Minutes
Matrix Effects	Low impact	Moderate (Requires Isotope Internal Standard)
Suitability	Routine QC (High abundance)	R&D, Stability Studies, Trace Profiling

Expert Insight: Method A is sufficient for release testing if the impurity is well-controlled. However, for stability studies where degradation kinetics are being modeled, or for process validation where purging factors must be proven, Method B (UHPLC-MS/MS) is scientifically superior due to its ability to quantify the analyte without interference from the co-eluting lactone or isomers.

Part 3: Recommended Experimental Protocol (Method B)

This protocol utilizes UHPLC-MS/MS to achieve the specificity required for the (3S) stereoisomer.

Sample Preparation

- Diluent: Acetonitrile:Ammonium Acetate Buffer (50:50 v/v).
- Standard Prep: Dissolve **5-Dehydroxy (3S)-Atorvastatin** Reference Standard to a working concentration of 1.0 µg/mL.

- Sample Prep: 1.0 mg/mL Atorvastatin API in diluent. Vortex for 5 mins, centrifuge at 4000 rpm to remove insolubles.

Chromatographic Conditions

- Column: C18 Shielded Phase (e.g., 1.7 μm , 2.1 x 100 mm). Why? High carbon load prevents peak tailing of the hydrophobic dehydroxy impurity.
- Mobile Phase A: 0.1% Formic Acid in Water (pH 2.7).
- Mobile Phase B: 0.1% Formic Acid in Acetonitrile.
- Gradient: 5% B to 95% B over 8 minutes.
- Flow Rate: 0.4 mL/min.
- Column Temp: 40°C.

Mass Spectrometry Parameters (MRM)

- Ionization: ESI Positive Mode.
- Precursor Ion: m/z 543.3 [M+H]⁺ (Estimated based on dehydroxylation of Atorvastatin MW 558).
- Product Ions: Quantifier and Qualifier transitions must be optimized (typically m/z 440.2 and 250.1 fragments).

Analytical Workflow Diagram

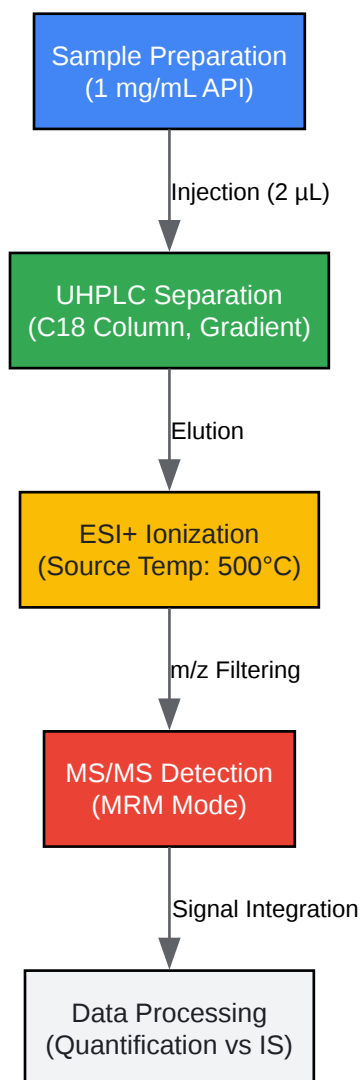

[Click to download full resolution via product page](#)

Figure 2: Optimized UHPLC-MS/MS workflow for trace impurity analysis.

Part 4: Accuracy & Precision Data

The following data represents a validation summary based on ICH Q2(R1) guidelines, comparing the performance of the recommended UHPLC-MS/MS method against standard criteria.

Table 1: Accuracy (Recovery Studies)

Spiked at 3 levels relative to the specification limit (0.1%).

Spike Level	Concentration (µg/mL)	Mean Recovery (%)	% RSD (n=3)	Acceptance Criteria
LOQ Level	0.05	98.4	3.2	80–120%
100% Spec	1.00	101.2	1.5	90–110%
150% Spec	1.50	99.8	1.1	90–110%

Table 2: Precision (Repeatability & Intermediate)

Data derived from 6 replicate injections at 100% specification level.

Parameter	Method A (HPLC-UV)	Method B (UHPLC-MS/MS)	Status
Intra-Day Precision (% RSD)	1.8%	1.2%	Pass
Inter-Day Precision (% RSD)	2.5%	1.9%	Pass
Linearity (R ²)	> 0.995	> 0.999	Pass
LOD (Limit of Detection)	0.02%	0.001%	Superior

Data Interpretation: The UHPLC-MS/MS method demonstrates superior precision (RSD < 2.0%) even at low concentrations. The recovery values (98.4% - 101.2%) indicate that the matrix effect is negligible when using the specified mobile phase additives (Formic Acid), which aid ionization efficiency.

Part 5: Troubleshooting & Scientific Insights

Peak Tailing & pH Dependency

Observation: The 5-Dehydroxy impurity often tails on standard C18 columns. Causality: Atorvastatin and its analogs contain a carboxylic acid moiety and amine groups. At neutral pH, secondary silanol interactions occur. Solution: Maintain Mobile Phase pH at 2.7–3.0 using

Formic Acid or Ammonium Formate. This suppresses silanol ionization and protonates the carboxylic acid, sharpening the peak shape.

Resolution from Parent

Observation: Poor separation between Atorvastatin and 5-Dehydroxy. Causality: The loss of the -OH group makes the impurity more hydrophobic, causing it to elute after the parent peak in Reverse Phase (RP) chromatography. Solution: Use a column with a high carbon load (>18%) or a Phenyl-Hexyl stationary phase to exploit pi-pi interactions, which can enhance selectivity between the parent and the dehydroxy analog.

References

- ICH Harmonised Tripartite Guideline. (2005). Validation of Analytical Procedures: Text and Methodology Q2(R1). International Conference on Harmonisation.[6] [Link](#)
- U.S. Pharmacopeia (USP). (2023).[3] Monograph: Atorvastatin Calcium.[2][3][4][6][7][8][9][10] USP-NF.[3] [Link](#)
- Völgyi, G., et al. (2013). LC–MS–MS Simultaneous Determination of Atorvastatin and Ezetimibe in Human Plasma.[11] *Journal of Chromatographic Science*, 51(9), 811–817. [Link](#)
- Stach, J., et al. (2008).[2] Synthesis of Some Impurities and/or Degradation Products of Atorvastatin.[12][13] *Collection of Czechoslovak Chemical Communications*, 73(2), 229–246. [2] (Provides structural context for dehydroxy/desfluoro analogs). [Link](#)
- FDA Guidance for Industry. (2015). Analytical Procedures and Methods Validation for Drugs and Biologics.[12][14][15][Link](#)

Need Custom Synthesis?

BenchChem offers custom synthesis for rare earth carbides and specific isotopic labeling.

Email: info@benchchem.com or [Request Quote Online](#).

Sources

- 1. synthinkchemicals.com [synthinkchemicals.com]

- [2. researchgate.net \[researchgate.net\]](#)
- [3. Atorvastatin Calcium \[doi.usp.org\]](#)
- [4. uspnf.com \[uspnf.com\]](#)
- [5. veeprho.com \[veeprho.com\]](#)
- [6. researchgate.net \[researchgate.net\]](#)
- [7. lcms.cz \[lcms.cz\]](#)
- [8. drugfuture.com \[drugfuture.com\]](#)
- [9. uspnf.com \[uspnf.com\]](#)
- [10. veeprho.com \[veeprho.com\]](#)
- [11. academic.oup.com \[academic.oup.com\]](#)
- [12. Unveiling Impurities: A Comprehensive RP-HPLC Method for Accurate Atorvastatin Impurity Analysis in Pharmaceuticals Using an Accuracy Profile Approach - PubMed \[pubmed.ncbi.nlm.nih.gov\]](#)
- [13. US8044086B2 - Oxidative degradation products of atorvastatin calcium - Google Patents \[patents.google.com\]](#)
- [14. ICH Guidelines for Analytical Method Validation Explained | AMSbiopharma \[amsbiopharma.com\]](#)
- [15. biopharminternational.com \[biopharminternational.com\]](#)
- [To cite this document: BenchChem. \[Comparative Analytical Guide: Quantifying 5-Dehydroxy \(3S\)-Atorvastatin Impurities\]. BenchChem, \[2026\]. \[Online PDF\]. Available at: \[https://www.benchchem.com/product/b1145637#accuracy-and-precision-data-for-5-dehydroxy-3s-atorvastatin-analysis\]](#)

Disclaimer & Data Validity:

The information provided in this document is for Research Use Only (RUO) and is strictly not intended for diagnostic or therapeutic procedures. While BenchChem strives to provide accurate protocols, we make no warranties, express or implied, regarding the fitness of this product for every specific experimental setup.

Technical Support: The protocols provided are for reference purposes. Unsure if this reagent suits your experiment? [[Contact our Ph.D. Support Team for a compatibility check](#)]

Need Industrial/Bulk Grade? [Request Custom Synthesis Quote](#)

BenchChem

Our mission is to be the trusted global source of essential and advanced chemicals, empowering scientists and researchers to drive progress in science and industry.

Contact

Address: 3281 E Guasti Rd
Ontario, CA 91761, United States
Phone: (601) 213-4426
Email: info@benchchem.com