

difference between sodium and ammonium phosphotungstate

Author: BenchChem Technical Support Team. **Date:** April 2026

Compound of Interest

Compound Name: *ammonium phosphotungstate n-hydrate*
CAS No.: *12026-92-5*
Cat. No.: *B1143584*

[Get Quote](#)

Technical Guide: Sodium vs. Ammonium Phosphotungstate

Executive Summary

Sodium Phosphotungstate ($\text{Na}_3\text{PW}_{12}\text{O}_{40}$) and Ammonium Phosphotungstate ($(\text{NH}_4)_3\text{PW}_{12}\text{O}_{40}$) are both salts of the heteropolyacid phosphotungstic acid (HPW) featuring the Keggin structure. Despite sharing the same polyoxometalate (POM) anion, their functional applications are diametrically opposed due to a single critical physicochemical divergence: solubility.

- Sodium Phosphotungstate (Na-PTA): Highly water-soluble.^{[1][2]} It is the gold standard for negative staining in transmission electron microscopy (TEM) at neutral pH.
- Ammonium Phosphotungstate (APT): Water-insoluble (precipitate). It is a high-performance solid acid catalyst used in heterogeneous organic synthesis due to its high surface acidity and ease of recovery.

Chemical Foundation: The Keggin Structure

Both compounds are based on the

-Keggin anion

. This cluster consists of a central heteroatom (Phosphorus) surrounded by four oxygen atoms to form a tetrahedron

, which is enclosed in a cage of 12 octahedral

units.

- Anion:

(Geometry: Td symmetry).

- Cation Exchange: The protons (

) in the parent acid (

) are exchanged for

or

.

- Na-Salt: The ionic radius of

allows for high hydration energy, leading to full dissociation in water.

- NH₄-Salt: The

ion has a specific ionic radius (1.43 Å) that matches the interstitial voids of the Keggin lattice, leading to a rigid, insoluble crystal packing with high porosity.

Sodium Phosphotungstate: The Biological Imaging Standard

Mechanism of Action

In biological electron microscopy, contrast is generated by the scattering of electrons. Biological materials (proteins, viruses, lipids) consist of light atoms (C, H, O, N) that scatter electrons poorly. Sodium phosphotungstate provides a "negative stain" by surrounding the particle with a heavy metal (Tungsten, $Z=74$) envelope.

Unlike the parent acid ($\text{pH} < 2$), which destroys delicate protein structures, the sodium salt allows for buffering to neutral pH (6.5–7.5). This preserves the native conformation of pH -sensitive viral capsids and protein complexes.

Protocol: Preparation of Neutral Na-PTA Stain

- Objective: Create a 2% (w/v) neutral negative stain solution.
- Reagents: Phosphotungstic Acid (Crystal), 1M NaOH, Distilled Water ().

Step-by-Step Workflow:

- Dissolution: Dissolve 20 mg of Phosphotungstic Acid crystals in 0.8 mL of . The solution will be highly acidic ($\text{pH} \sim 1-2$).
- Neutralization: Critical Step. Slowly add 1M NaOH dropwise while monitoring with a pH meter.
 - Target: pH 7.0.
 - Note: Do not overshoot to $\text{pH} > 8$, as the Keggin structure degrades into lacunary species (e.g.,) in alkaline conditions.
- Volume Adjustment: Add to a final volume of 1.0 mL.
- Filtration: Filter through a 0.22

syringe filter to remove dust or undissolved micro-crystals.

- Storage: Store at 4°C. Discard if precipitate appears.

Ammonium Phosphotungstate: The Solid Acid Catalyst

Mechanism of Action

Ammonium phosphotungstate is a "proton sponge." While insoluble in water and non-polar solvents, it possesses a unique secondary pore structure (mesopores) created during precipitation. This structure allows reactants to diffuse into the bulk crystal lattice, accessing internal acidic protons.

- Acidity: It exhibits superacidic properties (Hammett acidity function H_0).
- Heterogeneity: Unlike the soluble acid, APT precipitates out of reaction mixtures, allowing for filtration and reuse (Green Chemistry).

Protocol: Synthesis of High-Surface-Area APT Catalyst

- Objective: Synthesize $(\text{NH}_4)_2\text{APT}$ (a stoichiometry often cited for optimal catalytic activity due to residual protons).

Step-by-Step Workflow:

- Precursor Prep: Dissolve 10 g of Phosphotungstic Acid in 50 mL of H_2O .
- Precipitation: Add a stoichiometric amount of Ammonium Chloride (NH_4Cl) or Ammonium Carbonate solution dropwise with vigorous stirring.
 - Observation: A heavy white/yellow precipitate forms immediately.

- Aging: Stir the suspension for 3 hours at room temperature to allow crystal ripening (enhances pore structure).
- Isolation: Filter the solid using a Buchner funnel.
- Washing: Wash with

(to remove excess chloride) and then ethanol.
- Activation: Dry at 120°C for 4 hours. Calcination at 300°C may be performed to further increase surface acidity, but avoid temperatures >450°C to prevent decomposition of the Keggin cage.

Comparative Data Analysis

Feature	Sodium Phosphotungstate (Na-PTA)	Ammonium Phosphotungstate (APT)
Formula		
Solubility (Water)	High (> 50 g/100 mL)	Insoluble / Negligible
Surface Area (BET)	Low (< 5)	High (50–150)
Primary Application	Microscopy (Negative Stain)	Catalysis (Solid Acid)
pH Stability	Stable pH 1–7 (Degrades > pH 8)	Stable in acidic media
Recovery	Difficult (requires evaporation)	Easy (Filtration)

Visualizations

Figure 1: Application Decision Matrix

This diagram illustrates the logical flow for selecting the correct salt based on the research objective.

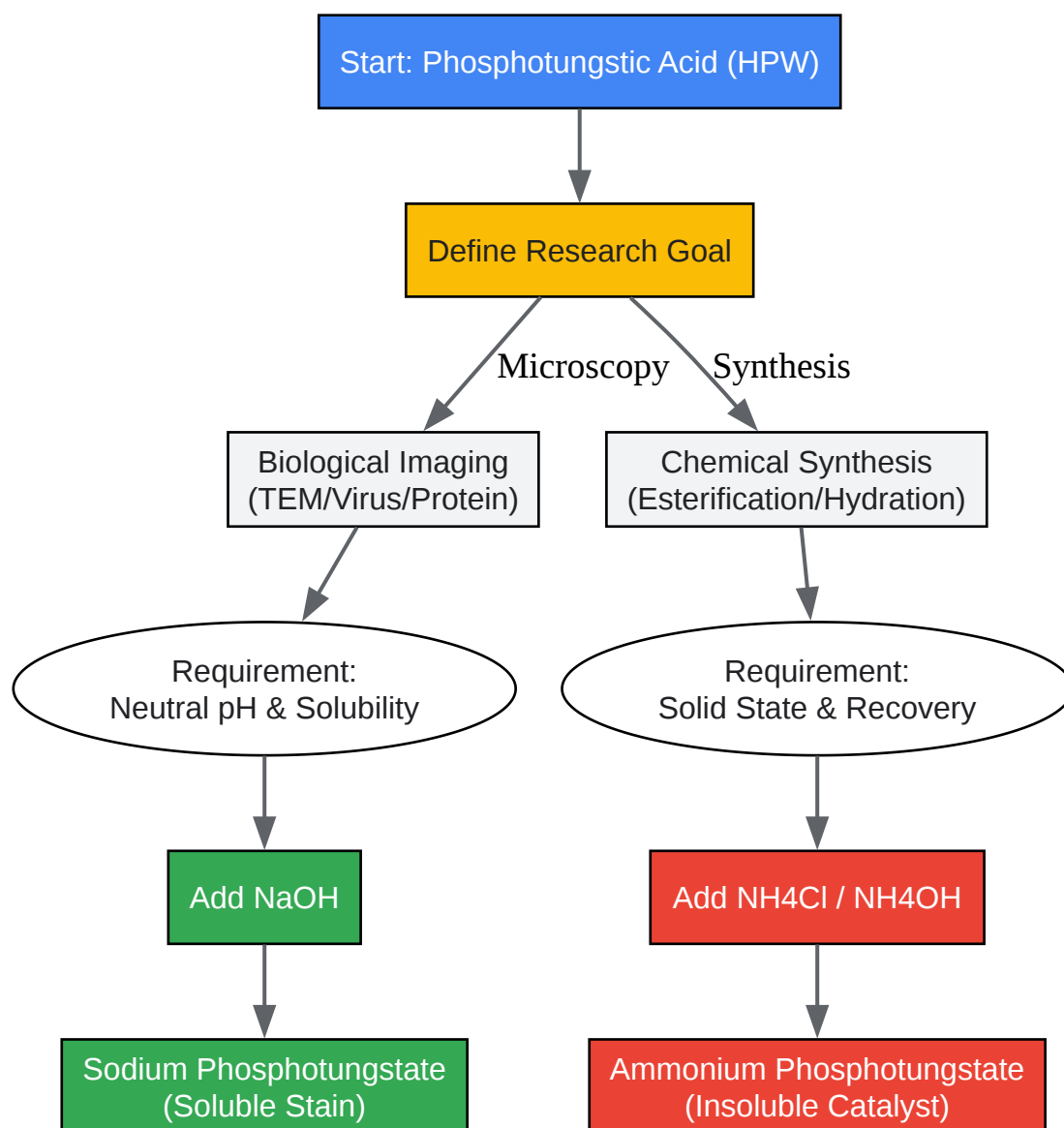

[Click to download full resolution via product page](#)

Caption: Decision matrix for selecting Sodium vs. Ammonium salts based on solubility requirements.

Figure 2: Synthesis & Structure Workflow

This diagram details the chemical transformation from the parent acid to the specific functional salt.

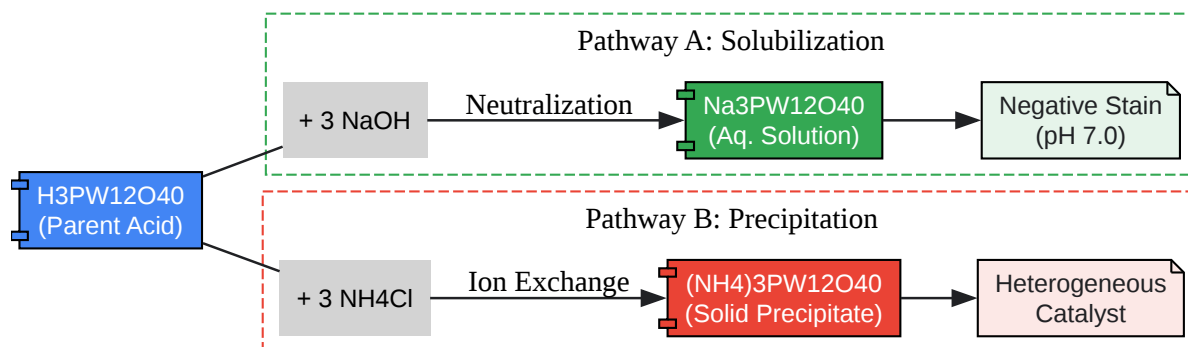

[Click to download full resolution via product page](#)

Caption: Synthesis pathways transforming Phosphotungstic Acid into functional Na (soluble) or NH₄ (solid) salts.

References

- Gunkel, M., Macha, A., & Behrmann, E. (2024).[3] Revisiting sodium phosphotungstate and ammonium molybdate as non-radioactive negative-staining agents for single-particle analysis. Acta Crystallographica Section F. [Link](#)
- Brenner, S., & Horne, R. W. (1959).[4] A negative staining method for high resolution electron microscopy of viruses. Biochimica et Biophysica Acta. [Link](#)
- Misono, M. (2001). Unique acid catalysis of heteropoly compounds (heteropolyacids). Chemical Communications. [Link](#)
- Okuhara, T., Mizuno, N., & Misono, M. (1996). Catalytic Chemistry of Heteropoly Compounds. Advances in Catalysis. [Link](#)
- GuideChem. (n.d.). Sodium Phosphotungstate Properties and Applications. [Link](#)

Need Custom Synthesis?

BenchChem offers custom synthesis for rare earth carbides and specific isotopic labeling.

Email: info@benchchem.com or [Request Quote Online](#).

Sources

- [1. wap.guidechem.com](http://wap.guidechem.com) [wap.guidechem.com]
- [2. Page loading...](#) [guidechem.com]
- [3. Revisiting sodium phosphotungstate and ammonium molybdate as nonradioactive negative-staining agents for single-particle analysis - PubMed](#) [pubmed.ncbi.nlm.nih.gov]
- [4. biorxiv.org](http://biorxiv.org) [biorxiv.org]
- To cite this document: BenchChem. [difference between sodium and ammonium phosphotungstate]. BenchChem, [2026]. [Online PDF]. Available at: [<https://www.benchchem.com/product/b1143584/docs#difference-between-sodium-and-ammonium-phosphotungstate>]

Disclaimer & Data Validity:

The information provided in this document is for Research Use Only (RUO) and is strictly not intended for diagnostic or therapeutic procedures. While BenchChem strives to provide accurate protocols, we make no warranties, express or implied, regarding the fitness of this product for every specific experimental setup.

Technical Support: The protocols provided are for reference purposes. Unsure if this reagent suits your experiment?

Need Industrial/Bulk Grade? [Request Custom Synthesis Quote](#)

BenchChem

Our mission is to be the trusted global source of essential and advanced chemicals, empowering scientists and researchers to drive progress in science and industry.

Contact

Address: 3281 E Guasti Rd

Ontario, CA 91761, United States

Phone: (601) 213-4426

Email: info@benchchem.com

Contact our Ph.D. Support Team for a compatibility check