

Technical Support Center: Purification of Tetraammineplatinum(II) Chloride

Author: BenchChem Technical Support Team. **Date:** May 2026

Compound of Interest

Compound Name: Tetraamineplatinum (II) chloride

CAS No.: 13933-32-9

Cat. No.: B1143899

[Get Quote](#)

Topic: Purification of Tetraammineplatinum(II) Chloride (

) via Cation Exchange Ticket ID: Pt-IX-PRO-001 Assigned Specialist: Senior Application Scientist, Inorganic Separations Division

Executive Summary & Scientific Rationale

Objective: To isolate high-purity

(TAP-Cl) from crude reaction mixtures containing Magnus's Green Salt (

), unreacted potassium tetrachloroplatinate (

), or hydrolysis byproducts.

The Mechanism: The purification relies on the distinct electrostatic properties of the square-planar tetraammineplatinum(II) cation,

. Unlike the anionic starting material (

) or the neutral non-electrolytes (

), the target molecule is a divalent cation.

We utilize a Strong Acid Cation (SAC) exchange resin (sulfonic acid functionalized polystyrene). The resin selectively binds

, allowing anionic impurities (chloride, chloroplatinates) and neutral species to pass through during the wash phase. The target is subsequently eluted using a high-concentration counter-ion (Proton,

), yielding the pure chloride salt upon evaporation with Hydrochloric Acid.

The "Golden Path" Protocol

This workflow assumes you are starting with a crude mixture derived from the reaction of and ammonia.

Phase 1: Pre-Treatment (Solubilization)

Critical Step: You cannot load Magnus's Green Salt (MGS) directly onto the column as it is an insoluble polymer. It must be depolymerized first.

- Suspension: Suspend the crude green solid in minimal water.
- Ammonolysis: Add concentrated (28-30%) until the solution is strongly alkaline.
- Reflux: Boil gently until the green precipitate dissolves completely, forming a clear, pale yellow solution.
 - Chemistry:
- Cooling: Cool to room temperature. Filter any residual solids (metallic Pt or silica).

Phase 2: Ion Exchange Chromatography

Materials:

- Resin: Dowex 50W-X8 (or Amberlite IR-120), 100-200 mesh.
- Column: Glass column with fritted disc (approx. 10-20mm ID).
- Eluent A: Deionized Water (18.2 MΩ).
- Eluent B: 3.0 M HCl (Hydrochloric Acid).

Step	Action	Technical Note
1. Activation	Slurry resin in water. Pour into column. Pass 3 Bed Volumes (BV) of 3M HCl, then wash with water until effluent is neutral (pH ~7).	Ensures resin is in the form and free of contaminants.
2. Loading	Slowly load the clear yellow ammoniacal solution onto the resin bed. Flow rate: ~1 mL/min.	The yellow band () will bind to the top of the column.
3. Washing	Pass Deionized Water (5-10 BV) through the column. Monitor effluent for using test.	Continue washing until no white precipitate () forms in the effluent. This confirms removal of non-bound anions.
4. Elution	Switch to 3.0 M HCl. Collect fractions. The yellow band will migrate down and elute.	The high displaces the Pt cation. The effluent is now in HCl.

Phase 3: Isolation

- Evaporation: Transfer the yellow eluate to a rotary evaporator. Evaporate to near dryness under reduced pressure (bath temp < 50°C).

- Crystallization: Add ethanol to the concentrated residue to precipitate the white/pale-yellow crystals.
- Drying: Filter and dry in a desiccator.

Workflow Visualization

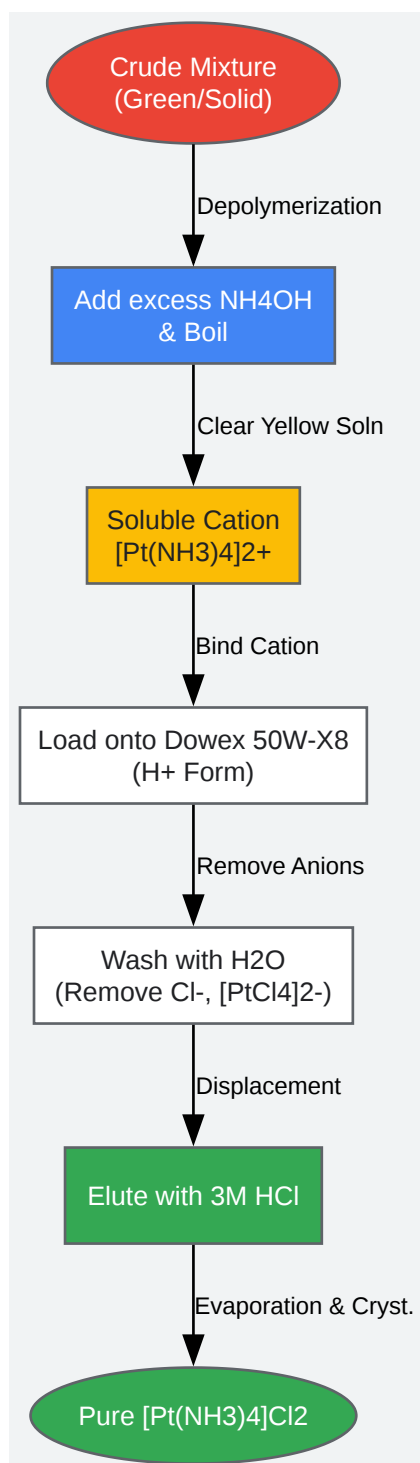

[Click to download full resolution via product page](#)

Caption: Figure 1.[1][2] The "Golden Path" purification workflow for Tetraammineplatinum(II) Chloride using cation exchange chromatography.

Troubleshooting Guide (Diagnostics)

Symptom 1: The column turned green during loading.

- Diagnosis: Premature precipitation of Magnus's Green Salt. This happens if the local concentration of Pt^{2+} and free NH_3 (impurities) interact within the resin pores, or if the pH dropped too fast inside the acidic resin, reversing the equilibrium.
- Fix:
 - Stop the flow.
 - Pass 1-2 BV of concentrated ammonia water through the column. This should re-dissolve the green precipitate on the column.
 - Wash thoroughly with water before resuming acid elution.

Symptom 2: Low Yield / Platinum Breakthrough.

- Diagnosis: Resin capacity exceeded.
- Calculation: Dowex 50W-X8 has a capacity of ~1.7 meq/mL (wet).
 - Molar Mass of $\text{Pt}(\text{NH}_3)_4\text{Cl}_2$ is ~263 g/mol .
 - Valence = +2.
 - Therefore, 1 mL of resin binds approx. 1.7 meq/mL \times 263 g/mol \div 2 = 223 mg/mL.

mg of Pt complex.

- Fix: Ensure you are using at least 20% excess resin volume calculated against your theoretical yield.

Symptom 3: Product is yellow but turns black upon heating.

- Diagnosis: Contamination with metallic platinum or hydrolysis to hydroxides.
- Fix: Ensure the evaporation temperature does not exceed 60°C. High heat in the presence of moisture can promote hydrolysis of the ammine ligands.

Decision Logic Tree

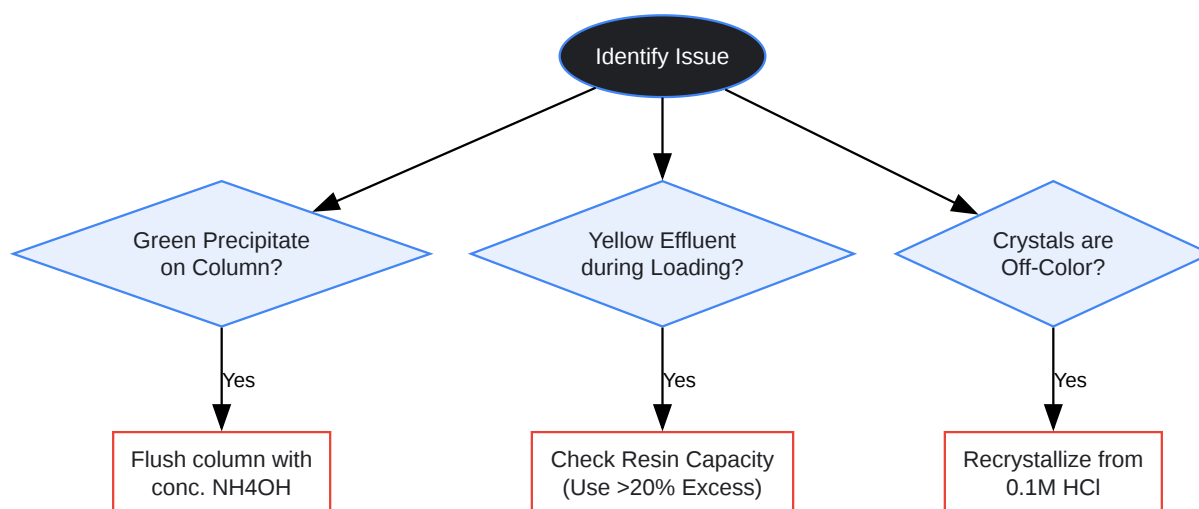

[Click to download full resolution via product page](#)

Caption: Figure 2. Diagnostic decision tree for common purification anomalies.

Frequently Asked Questions (FAQ)

Q: Why use Dowex 50W-X8 specifically? Can I use X4 or X2? A: We recommend X8 (8% cross-linking). Lower cross-linked resins (X2, X4) swell significantly more and have larger pores. While this allows faster kinetics, it reduces the physical selectivity and "sieve" effect. X8

offers the best balance of mechanical stability and kinetics for small inorganic complexes like TAP.

Q: Can I elute with NaCl instead of HCl? A: Technically yes, but it is not recommended. Eluting with NaCl would leave you with a mixture of

and excess NaCl. Separating these two salts is difficult as both are water-soluble. Using HCl allows you to simply evaporate the excess eluent (HCl + Water), leaving pure product.

Q: My crude starting material is

. Can I skip the isolation of the green salt? A: Yes. The modern "one-pot" synthesis involves reacting

with excess ammonia, then boiling to ensure all Magnus salt is converted to

. This solution can be filtered and applied directly to the ion exchange column, which effectively removes the potassium (

) ions (which bind less strongly than the divalent Pt complex) and the chloride ions (which pass through). Note:

removal requires careful elution control, but typically the divalent Pt species binds much tighter.

References

- Synthesis of Tetraammineplatinum(II) Chloride. *Inorganic Syntheses*, Vol. 2, p. 250. (Classic method for converting Magnus's salt).
- Cation Exchange Separation of Platinum Ammines. *Journal of the American Chemical Society*. (Foundational work on Pt-ammine stability).
- Dowex Ion Exchange Resin User Manual. DuPont Water Solutions.
- Preparation of Platinum(II) Ammines. Vertex Synthesis Database / Patent CN102328962A. (Describes the boiling ammonia method for depolymerization).

Need Custom Synthesis?

BenchChem offers custom synthesis for rare earth carbides and specific isotopic labeling.

Email: info@benchchem.com or [Request Quote Online](#).

Sources

- [1. Research Collection | ETH Library \[research-collection.ethz.ch\]](#)
- [2. researchgate.net \[researchgate.net\]](#)
- To cite this document: BenchChem. [Technical Support Center: Purification of Tetraammineplatinum(II) Chloride]. BenchChem, [2026]. [Online PDF]. Available at: [<https://www.benchchem.com/product/b1143899/docs#technical-support-center-purification-of-tetraammineplatinum-ii-chloride>]

Disclaimer & Data Validity:

The information provided in this document is for Research Use Only (RUO) and is strictly not intended for diagnostic or therapeutic procedures. While BenchChem strives to provide accurate protocols, we make no warranties, express or implied, regarding the fitness of this product for every specific experimental setup.

Technical Support: The protocols provided are for reference purposes. Unsure if this reagent suits your experiment?

Need Industrial/Bulk Grade? [Request Custom Synthesis Quote](#)

BenchChem

Our mission is to be the trusted global source of essential and advanced chemicals, empowering scientists and researchers to drive progress in science and industry.

Contact

Address: 3281 E Guasti Rd
Ontario, CA 91761, United States
Phone: (601) 213-4426
Email: info@benchchem.com

[Contact our Ph.D. Support Team for a compatibility check](#)

