

# Precision Doping in Optoelectronics: Thulium(III) Chloride Hexahydrate Protocols

**Author:** BenchChem Technical Support Team. **Date:** May 2026

## Compound of Interest

Compound Name:	THULIUM(III) CHLORIDE HEXAHYDRATE
CAS No.:	1331-74-4
Cat. No.:	B1143357

[Get Quote](#)

) Application: Fabrication of Blue-Emitting Perovskites and NIR-to-Visible Upconversion Devices

## Executive Summary & Material Profile

**Thulium(III) chloride hexahydrate** is a critical trivalent lanthanide precursor used to engineer band structures in next-generation optoelectronics. Unlike its oxide counterparts, the chloride salt offers superior solubility in polar organic solvents (DMF, DMSO) and water, making it the preferred dopant source for solution-processed Halide Perovskite LEDs (PeLEDs) and Upconversion Nanoparticles (UCNPs).

This guide details the specific protocols for utilizing

to induce blue emission (~470 nm) in perovskite lattices and to synthesize precursors for deep-tissue bio-imaging probes.

## Physicochemical Profile

Property	Specification	Relevance to Optoelectronics
Formula		High solubility in polar solvents used for spin-coating.
Purity	99.99% (4N) or 99.999% (5N)	Trace metals (Fe, Cu) quench luminescence; >4N is mandatory.
Hygroscopicity	High	Critical: Absorbs atmospheric water rapidly. Must be handled in inert atmosphere (glovebox) for non-aqueous protocols.
Coordination	9-coordinate (Solid state)	Water molecules must be displaced by ligands (e.g., oleic acid) or solvent molecules (DMSO) during synthesis.

## Application A: Blue-Emissive Perovskite LEDs (PeLEDs)

Target: Doping Cesium Lead Chloride (

) nanocrystals to achieve efficient blue emission. Mechanism:

ions substitute

sites, introducing paramagnetic centers and altering the excitonic recombination dynamics.

### Protocol: In-Situ Solution Doping

Note: Direct use of hexahydrate is permitted here as the solvent system (DMSO/DMF) tolerates hydration better than non-polar colloidal syntheses.

### Reagents

- (99.999%)

- (99.999%)
- (99.99%)
- Solvent: Dimethyl sulfoxide (DMSO)[1][2]
- Ligands: Oleylamine (OAm) and Oleic Acid (OA)

## Step-by-Step Methodology

- Precursor Preparation (Stoichiometric Tuning):
  - Prepare a 0.4 M precursor solution in DMSO.
  - Molar Ratio:  
=  
.
  - Optimization: Typical doping concentrations ( ) range from 0.5% to 5%. Excess Tm (>10%) leads to phase segregation and luminescence quenching.
  - Dissolution: Stir at 60°C for 2 hours inside a nitrogen-filled glovebox ( ppm, ppm). Ensure the hexahydrate is fully dissolved; the solution should be clear and colorless.
- Substrate Preparation:
  - Use ITO-coated glass substrates. Clean sequentially with detergent, deionized water, acetone, and isopropanol (15 min ultrasonication each).
  - Treat with UV-Ozone for 20 minutes to improve wettability.
- Thin Film Deposition (Spin-Coating):

- Dispense 50  $\mu\text{L}$  of the precursor solution onto the substrate.
- Spin Cycle: 3000 rpm for 60 seconds.
- Antisolvent Dripping (Critical Step): At  
  
seconds, rapidly drop 150  $\mu\text{L}$  of Chlorobenzene onto the spinning center. This induces rapid crystallization of the perovskite phase.
- Annealing:
  - Transfer immediately to a hotplate at 100°C for 10 minutes.
  - Observation: The film should turn transparent/whitish.
- Device Integration:
  - Deposit electron transport layer (e.g., TPBi) and cathode (LiF/Al) via thermal evaporation.

## Workflow Visualization (Graphviz)

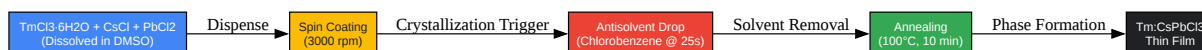

[Click to download full resolution via product page](#)

Figure 1: Fabrication workflow for Tm-doped Perovskite thin films using solution processing.

## Application B: Upconversion Nanoparticles (UCNPs)

Target: Synthesis of

nanoparticles for bio-imaging or photodetectors. Challenge: The "Hexahydrate" water content is detrimental to high-temperature thermal decomposition (300°C). Solution: Convert

into an anhydrous Thulium Oleate (

) precursor prior to nanoparticle growth.

## Protocol: Synthesis of Anhydrous Tm-Oleate Precursor

This step is mandatory to prevent hydrolysis during the high-temperature growth phase.

### Reagents

- [3]
- Sodium Oleate (Na-OA)
- Solvents: Ethanol, Distilled Water, Hexane

### Step-by-Step Methodology

- Dissolution:
  - Dissolve 1 mmol of  
  
in 2 mL of distilled water.
  - Dissolve 3 mmol of Sodium Oleate in a mixture of 3 mL ethanol, 3 mL water, and 7 mL hexane.
- Ligand Exchange Reaction:
  - Mix the two solutions in a round-bottom flask.
  - Reflux at 70°C for 4 hours with vigorous stirring. The Thulium ions transfer from the aqueous phase to the organic (hexane) phase as they bind with oleate ligands.
- Phase Separation & Washing:
  - Use a separatory funnel to isolate the upper organic layer (containing  
  
).
  - Wash with distilled water (3x) to remove NaCl byproducts.
- Dehydration (Critical):
  - Evaporate the hexane using a rotary evaporator.

- Dry the resulting waxy solid under vacuum at 60°C for 12 hours.
- Result: Anhydrous Thulium Oleate complex, ready for injection into the UCNP growth solution (typically Octadecene/Oleic acid at 300°C).

## Mechanism & Validation

To validate the successful incorporation of

, researchers must analyze the energy transfer pathways.

## Energy Transfer Mechanism

In UCNPs, Ytterbium (

) acts as the "antenna" (sensitizer), absorbing 980 nm NIR light and transferring energy to Thulium (

), which emits in the blue (475 nm) and UV regions.

Key Transitions:

- Excitation:  
via 980 nm laser.
- Energy Transfer (ET):  
. Multiple transfers promote Tm electrons up the ladder:  
.
- Emission: Radiative decay from  
yields Blue Light (~475 nm).

## Energy Diagram Visualization (Graphviz)

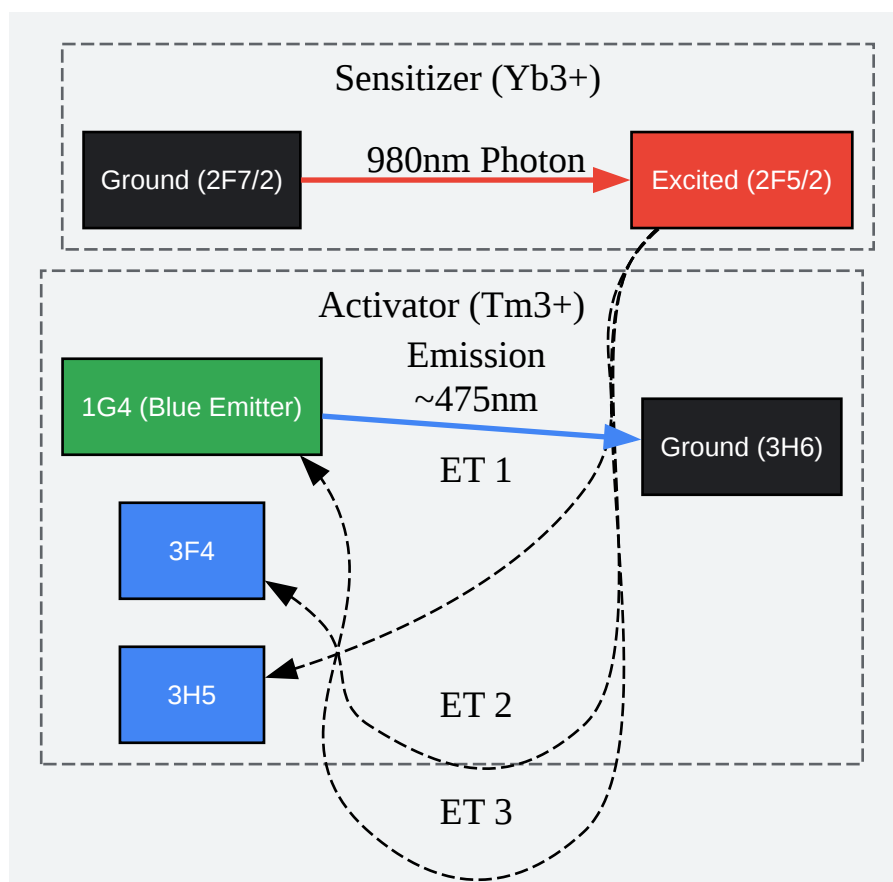

[Click to download full resolution via product page](#)

Figure 2: Simplified Energy Transfer (ET) diagram showing the upconversion process from Yb sensitizer to Tm activator.

## Validation Checklist

Method	Expected Result	Interpretation
XRD	Peak shift to higher angles	(0.88 Å) is smaller than (1.19 Å), causing lattice contraction.
PL Spectroscopy	Sharp peak at ~475 nm	Characteristic transition of .
XPS	Tm 4d peak appearance	Confirms chemical presence and oxidation state (+3).

## References

- Doping Mechanism in Perovskites
  - Pan, G., et al. (2020). "Doping Lanthanide into Perovskite Nanocrystals: Highly Improved and Expanded Optical Properties." Nano Letters.
- UCNP Synthesis Protocols
  - Wang, F., et al. (2010). "Simultaneous phase and size control of upconversion nanocrystals through lanthanide doping.
- Thulium Chloride Properties & Handling
  - Sigma-Aldrich.<sup>[1][2][3][4]</sup> "**Thulium(III) chloride hexahydrate** Product Specification."
- Energy Transfer Dynamics
  - Auzel, F. (2004). "Upconversion and Anti-Stokes Processes with f and d Ions in Solids." Chemical Reviews.

### Need Custom Synthesis?

BenchChem offers custom synthesis for rare earth carbides and specific isotopic labeling.

Email: [info@benchchem.com](mailto:info@benchchem.com) or [Request Quote Online](#).

## Sources

- [1. preprints.org \[preprints.org\]](https://preprints.org)
- [2. The Spectroscopic Properties and Microscopic Imaging of Thulium-Doped Upconversion Nanoparticles Excited at Different NIR-II Light - PMC \[pmc.ncbi.nlm.nih.gov\]](https://pubmed.ncbi.nlm.nih.gov/38111111/)
- [3. Thulium | Sigma-Aldrich \[sigmaaldrich.com\]](https://www.sigmaaldrich.com)
- [4. Thulium\(III\) chloride - Wikipedia \[en.wikipedia.org\]](https://en.wikipedia.org/wiki/Thulium(III)_chloride)
- To cite this document: BenchChem. [Precision Doping in Optoelectronics: Thulium(III) Chloride Hexahydrate Protocols]. BenchChem, [2026]. [Online PDF]. Available at: [\[https://www.benchchem.com/product/b1143357/docs#precision-doping-in-optoelectronics-thulium-iii-chloride-hexahydrate-protocols\]](https://www.benchchem.com/product/b1143357/docs#precision-doping-in-optoelectronics-thulium-iii-chloride-hexahydrate-protocols)

---

### Disclaimer & Data Validity:

The information provided in this document is for Research Use Only (RUO) and is strictly not intended for diagnostic or therapeutic procedures. While BenchChem strives to provide accurate protocols, we make no warranties, express or implied, regarding the fitness of this product for every specific experimental setup.

**Technical Support:** The protocols provided are for reference purposes. Unsure if this reagent suits your experiment?

**Need Industrial/Bulk Grade?** [Request Custom Synthesis Quote](#)

# BenchChem

Our mission is to be the trusted global source of essential and advanced chemicals, empowering scientists and researchers to drive progress in science and industry.

## Contact

Address: 3281 E Guasti Rd  
Ontario, CA 91761, United States  
Phone: (601) 213-4426  
Email: [info@benchchem.com](mailto:info@benchchem.com)

[Contact our Ph.D. Support Team for a compatibility check](#)