

# LMO Particle Characteristics: A Technical Support Guide for Researchers

**Author:** BenchChem Technical Support Team. **Date:** May 2026

## Compound of Interest

Compound Name: LITHIUM MANGANESE OXIDE

CAS No.: 12057-17-9

Cat. No.: B1143487

[Get Quote](#)

This technical support center provides troubleshooting guidance and frequently asked questions (FAQs) for researchers, scientists, and drug development professionals working with **Lithium Manganese Oxide (LMO)**. The following sections detail the impact of particle size and morphology on the electrochemical behavior of LMO, offering insights into common experimental challenges.

## Troubleshooting Guide

This guide addresses specific issues that may arise during your experiments with LMO cathode materials.

### Issue 1: Rapid Capacity Fading During Cycling

- **Possible Cause:** Manganese dissolution into the electrolyte is a common issue with LMO, leading to a loss of active material and capacity. This can be exacerbated by certain particle morphologies and high operating temperatures. Another potential cause is structural transformation upon cycling.
- **Troubleshooting Steps:**

- Material Characterization:
  - Post-cycling SEM: Analyze the morphology of the LMO particles after cycling to check for signs of degradation, such as cracking or particle fragmentation.
  - Post-cycling XRD: Examine the crystal structure to identify any phase transitions from the stable spinel structure.
- Electrolyte Analysis: Analyze the electrolyte for dissolved manganese ions using techniques like inductively coupled plasma (ICP) spectroscopy.
- Surface Modification: Consider surface coatings (e.g., with metal oxides) to suppress manganese dissolution and improve structural stability.[\[1\]](#)
- Particle Morphology Optimization: Synthesize LMO with a stable, well-defined morphology, such as spherical or single-crystal structures, which can exhibit better structural integrity. [\[2\]](#)

## Issue 2: High Cell Impedance

- Possible Cause: High impedance can stem from either high charge transfer resistance ( $R_{ct}$ ) at the electrode-electrolyte interface or high contact resistance ( $R_{cont}$ ) between particles and the current collector.
- Troubleshooting Steps:
  - Electrochemical Impedance Spectroscopy (EIS): Perform EIS to deconstruct the total impedance into its components. The semicircle in the high-to-medium frequency range typically corresponds to  $R_{ct}$ , while the intercept with the real axis at high frequency relates to the ohmic resistance, which includes  $R_{cont}$ .[\[1\]](#)[\[3\]](#)[\[4\]](#)
  - Particle Size Adjustment:
    - To reduce  $R_{ct}$ , consider using LMO with a smaller particle size to increase the electrochemical reaction surface area.[\[3\]](#)[\[4\]](#)

- To potentially lower  $R_{cont}$ , larger particles might be beneficial as they can lead to better particle-to-particle and particle-to-current collector contact.[\[3\]](#)[\[4\]](#)
- Electrode Formulation: Optimize the electrode composition, including the conductive additive and binder content, to ensure good electronic pathways and adhesion.

### Issue 3: Poor Rate Capability

- Possible Cause: Limited rate performance is often due to slow lithium-ion diffusion within the LMO particles or high charge transfer resistance.
- Troubleshooting Steps:
  - Particle Size Reduction: Smaller particles provide shorter diffusion paths for lithium ions, which is crucial for high-power applications.[\[5\]](#)[\[6\]](#)[\[7\]](#)
  - Morphology Engineering: Employ porous or nanostructured LMO morphologies. These structures can increase the electrode-electrolyte contact area and facilitate faster lithium-ion transport.
  - Electrochemical Characterization: Use galvanostatic charge-discharge tests at various C-rates to quantify the rate capability. Compare the specific capacity retention at high rates for different LMO materials.[\[1\]](#)

## Frequently Asked Questions (FAQs)

Q1: How does particle size fundamentally affect the electrochemical performance of LMO?

Smaller LMO particles generally offer a higher specific surface area, which leads to a lower charge transfer resistance and improved rate capability due to shorter lithium-ion diffusion pathways.[\[3\]](#)[\[5\]](#)[\[6\]](#)[\[8\]](#) However, an excessively small particle size can increase the surface area available for undesirable side reactions with the electrolyte, potentially leading to faster capacity fade. Conversely, larger particles may offer better thermal stability and lower contact resistance but can suffer from slower kinetics.[\[3\]](#)[\[4\]](#)[\[8\]](#)

Q2: What is the ideal morphology for LMO particles?

The ideal morphology aims to balance structural stability, electronic conductivity, and ionic diffusion.

- Spherical Morphology: Often preferred as it can lead to higher packing density in the electrode, better structural stability, and more uniform current distribution.[2][8]
- Single-Crystal Morphology: Can be advantageous for achieving good electrochemical performance due to the absence of grain boundaries that can impede ion transport and act as sites for degradation.[9]
- Porous/Nanostructured Morphology: Can significantly enhance rate capability by increasing the electrode-electrolyte interface and reducing diffusion lengths.[10]

Q3: Can surface modification of LMO particles improve their performance?

Yes, surface modifications, such as coating with metal oxides like  $\text{WO}_3$ , can significantly enhance the electrochemical performance of LMO.[1] These coatings can suppress manganese dissolution, improve structural stability, and enhance interfacial kinetics, leading to better cycling stability and rate capability.[1][11]

Q4: What are the key experimental techniques to characterize the impact of particle properties?

- Scanning Electron Microscopy (SEM): To visualize particle size, shape, and morphology.[1]
- X-ray Diffraction (XRD): To determine the crystal structure and phase purity.[1]
- Galvanostatic Charge-Discharge Cycling: To measure specific capacity, cycling stability, and rate capability.[1][12]
- Cyclic Voltammetry (CV): To study the electrochemical reaction kinetics and redox processes.[1]
- Electrochemical Impedance Spectroscopy (EIS): To investigate the different resistance components within the cell, such as charge transfer resistance and contact resistance.[1][3][4]

## Quantitative Data Summary

The following tables summarize the quantitative impact of LMO particle size on its electrochemical properties as reported in the literature.

Parameter	Effect of Decreasing Particle Size	Effect of Increasing Particle Size	Reference
Charge Transfer Resistance (R <sub>ct</sub> )	Decreases due to larger reaction surface area.	Increases.	[3]
Contact Resistance (R <sub>cont</sub> )	May slightly increase.	Slightly decreases.	[3]
Rate Capability	Generally improves due to shorter Li <sup>+</sup> diffusion paths.	Generally decreases.	[5][6][7]
Specific Capacity	The effect can be minimal, but very small particles may lead to lower initial capacity due to surface defects.	Can be comparable to smaller particles at low C-rates.	[3]
Cycling Stability	Can be reduced due to increased side reactions with the electrolyte.	Can be improved due to better structural stability.	[13][14]

## Experimental Protocols

### 1. Synthesis of LMO with Controlled Particle Size (Solid-State Reaction)

- **Precursor Mixing:** Stoichiometric amounts of Li<sub>2</sub>CO<sub>3</sub> and MnO<sub>2</sub> are mixed and ground in an agate mortar for at least 15 minutes, followed by ball milling for 1 hour at 500 rpm to ensure homogeneity.[1]
- **Calcination:** The mixture is then calcined in air. The particle size is controlled by the calcination temperature and duration. For example, calcining at 900°C for 12 hours can

produce LMO particles.[1] Varying the temperature and time (e.g., 1000°C for 2, 15, or 50 hours) will result in different particle sizes.[3]

- Characterization: The resulting powder is characterized using XRD for phase purity and SEM for particle size and morphology.

## 2. Electrochemical Impedance Spectroscopy (EIS) Measurement

- Cell Assembly: A coin cell is assembled with the LMO cathode, a lithium metal anode, and a suitable electrolyte.
- Instrumentation: A frequency response analyzer coupled with a potentiostat is used.
- Measurement Parameters: A sinusoidal AC voltage with a small amplitude (e.g., 5-10 mV) is applied over a wide frequency range (e.g., 100 kHz to 0.01 Hz).[5]
- Data Analysis: The resulting Nyquist plot is analyzed. The semicircle in the high-to-medium frequency region is fitted to an equivalent circuit model to determine the charge transfer resistance ( $R_{ct}$ ). The high-frequency intercept with the real axis represents the ohmic resistance ( $R_s$ ), which includes the contact resistance.[5]

## Visualizations

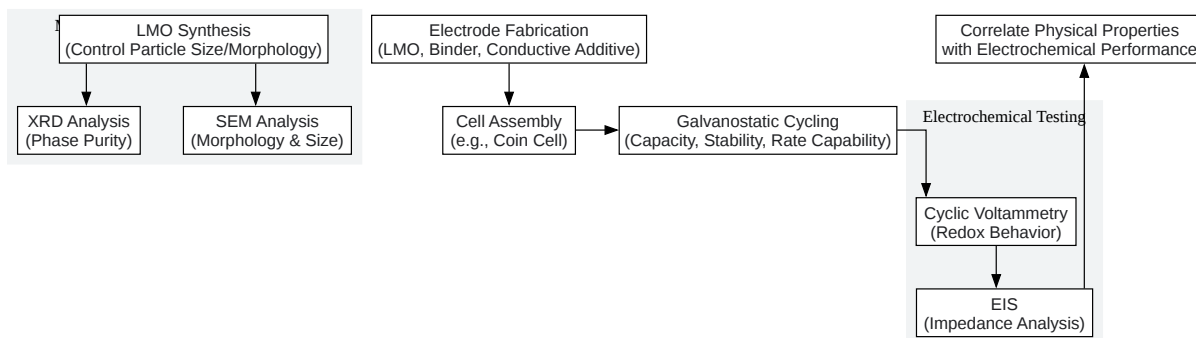

[Click to download full resolution via product page](#)

Caption: Experimental workflow for investigating LMO particle properties.

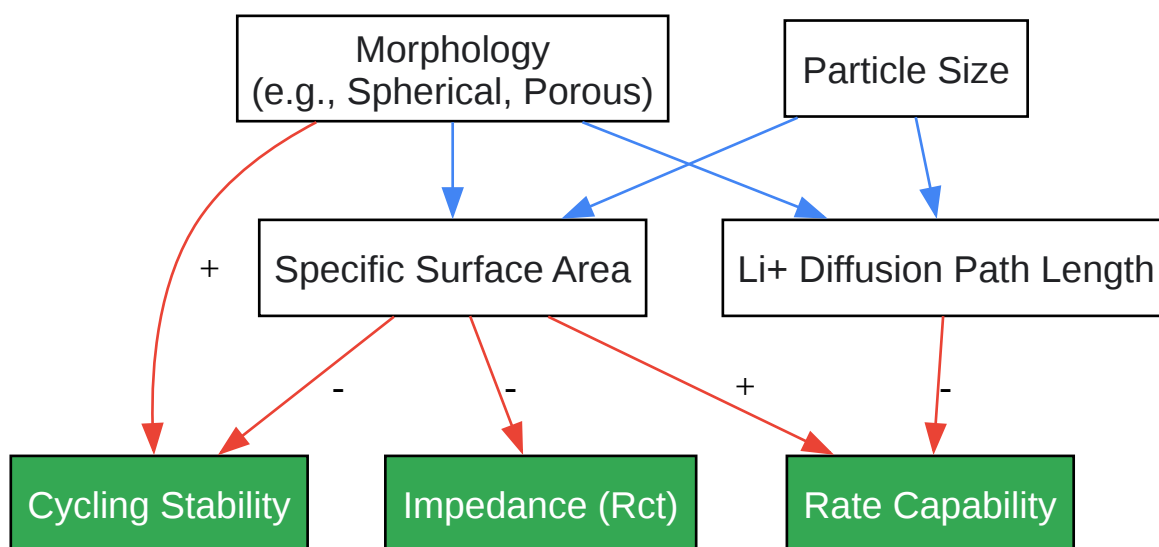

[Click to download full resolution via product page](#)

### Need Custom Synthesis?

BenchChem offers custom synthesis for rare earth carbides and specific isotopic labeling.

Email: [info@benchchem.com](mailto:info@benchchem.com) or [Request Quote Online](#).

## References

- [1. pubs.acs.org \[pubs.acs.org\]](https://pubs.acs.org)
- [2. researchgate.net \[researchgate.net\]](https://researchgate.net)
- [3. ocu-omu.repo.nii.ac.jp \[ocu-omu.repo.nii.ac.jp\]](https://ocu-omu.repo.nii.ac.jp)
- [4. researchgate.net \[researchgate.net\]](https://researchgate.net)
- [5. pubs.acs.org \[pubs.acs.org\]](https://pubs.acs.org)
- [6. Effect of Particle Size and Electronic Percolation on Low-Temperature Performance in Lithium Titanate-Based Batteries - PMC \[pmc.ncbi.nlm.nih.gov\]](#)
- [7. researchgate.net \[researchgate.net\]](https://researchgate.net)
- [8. azom.com \[azom.com\]](https://azom.com)
- [9. researchgate.net \[researchgate.net\]](https://researchgate.net)
- [10. Synthesizing high performance LNMO cathode materials with porous structure by manipulating reynolds number in a microreactor - PubMed \[pubmed.ncbi.nlm.nih.gov\]](#)
- [11. Significant Enhancement of the Capacity and Cycling Stability of Lithium-Rich Manganese-Based Layered Cathode Materials via Molybdenum Surface Modification - PMC \[pmc.ncbi.nlm.nih.gov\]](#)
- [12. researchgate.net \[researchgate.net\]](https://researchgate.net)
- [13. scribd.com \[scribd.com\]](https://scribd.com)
- [14. researchgate.net \[researchgate.net\]](https://researchgate.net)
- To cite this document: BenchChem. [LMO Particle Characteristics: A Technical Support Guide for Researchers]. BenchChem, [2026]. [Online PDF]. Available at: [\[https://www.benchchem.com/product/b1143487/docs#lmo-particle-characteristics-a-technical-support-guide-for-researchers\]](https://www.benchchem.com/product/b1143487/docs#lmo-particle-characteristics-a-technical-support-guide-for-researchers)

---

### Disclaimer & Data Validity:

The information provided in this document is for Research Use Only (RUO) and is strictly not intended for diagnostic or therapeutic procedures. While BenchChem strives to provide accurate protocols, we make no warranties, express or implied, regarding the fitness of this product for every specific experimental setup.

**Technical Support:** The protocols provided are for reference purposes. Unsure if this reagent suits your experiment?

**Need Industrial/Bulk Grade?** [Request Custom Synthesis Quote](#)

## BenchChem

Our mission is to be the trusted global source of essential and advanced chemicals, empowering scientists and researchers to drive progress in science and industry.

### Contact

Address: 3281 E Guasti Rd  
Ontario, CA 91761, United States  
Phone: (601) 213-4426  
Email: [info@benchchem.com](mailto:info@benchchem.com)

[Contact our Ph.D. Support Team for a compatibility check](#)