

Application Notes & Protocols: Solid-Phase Synthesis Using Benzotriazole Linkers

Author: BenchChem Technical Support Team. **Date:** May 2026

Compound of Interest

Compound Name: ((BENZOTRIAZOLE-1-YL)METHYLENE)

CAS No.: 187964-68-7

Cat. No.: B1143282

[Get Quote](#)

For Researchers, Scientists, and Drug Development Professionals

Foundational Principles: The Benzotriazole Moiety in Solid-Phase Synthesis

Solid-phase synthesis (SPS) has revolutionized the construction of complex molecules by anchoring a starting material to an insoluble polymer support, allowing for the use of excess reagents and simplified purification through washing.[1] A critical component of this methodology is the "linker," a molecular bridge connecting the synthesized molecule to the solid support. Benzotriazole-based linkers and reagents have emerged as exceptionally versatile and efficient tools in the synthetic chemist's arsenal, particularly in the challenging field of peptide and heterocyclic synthesis.[2][3]

The power of benzotriazole lies in its dual nature. The 1H-benzotriazole scaffold can function as both an excellent leaving group and a potent activating agent for carboxylic acids.[4] This activation is central to its most common application in peptide synthesis, where 1-Hydroxybenzotriazole (HOBt) is used as an additive in carbodiimide-mediated couplings.[5][6]

The HOBt reacts with the carbodiimide-activated amino acid to form an active ester intermediate, which is more stable and less prone to racemization than the initial O-acylisourea intermediate.[6] This suppression of racemization is critical for maintaining the stereochemical integrity of the final peptide product.[7]

Beyond its role as an additive, the benzotriazole group can be directly incorporated into the linker structure, tethered to the solid support.[3][8] In these systems, the molecule of interest is attached to the resin via the benzotriazole linker. Upon completion of the synthesis, the linker is activated, often by diazotization of a precursor, transforming the benzotriazole into a highly reactive species that can be readily displaced by a wide range of nucleophiles.[4][9] This "traceless" cleavage strategy allows for the introduction of diverse functionality at the C-terminus of a peptide or a specific position on a small molecule, releasing the final product from the resin without leaving a molecular remnant of the linker.[3][4]

Mechanism of Action: Activation and Cleavage

The efficacy of benzotriazole-based strategies hinges on two key chemical transformations: the activation of a carboxyl group for coupling and the cleavage of the final product from the solid support.

Carboxyl Group Activation for Amide Bond Formation

In peptide synthesis, coupling reagents like HBTU (2-(1H-benzotriazol-1-yl)-1,1,3,3-tetramethyluronium hexafluorophosphate) and TBTU incorporate the HOBt moiety directly.[10][11] The general mechanism involves the reaction of the carboxyl group of an incoming amino acid with the coupling reagent to form a highly reactive HOBt active ester.[12] This ester is then susceptible to nucleophilic attack by the free amine of the resin-bound peptide chain, forming the desired peptide bond with high efficiency and minimal side reactions.[7][11] The use of HOBt or its derivatives significantly accelerates coupling reactions, which is essential for the successful synthesis of long or "difficult" peptide sequences.[10][13]

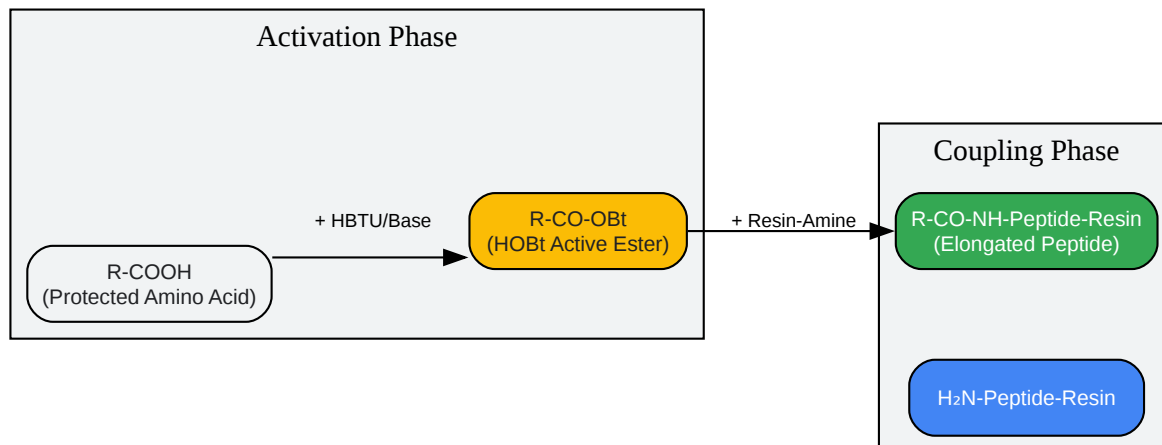

[Click to download full resolution via product page](#)

Caption: Benzotriazole-mediated carboxyl activation and coupling.

On-Resin C-Terminal Modification and Cleavage

A powerful application of benzotriazole linkers involves the on-resin modification of a peptide's C-terminus.[4][9] A common strategy employs a resin functionalized with 3,4-diaminobenzoic acid. After the peptide chain is assembled, the diaminobenzoyl group is treated with a nitrite source (e.g., isoamyl nitrite) to form a resin-bound benzotriazole active ester of the peptide.[9] This activated C-terminus can then be cleaved from the resin by a diverse array of nucleophiles. This method allows for the synthesis of C-terminal acids (using water), esters (using alcohols), amides (using amines), or even thioesters for native chemical ligation.[4]

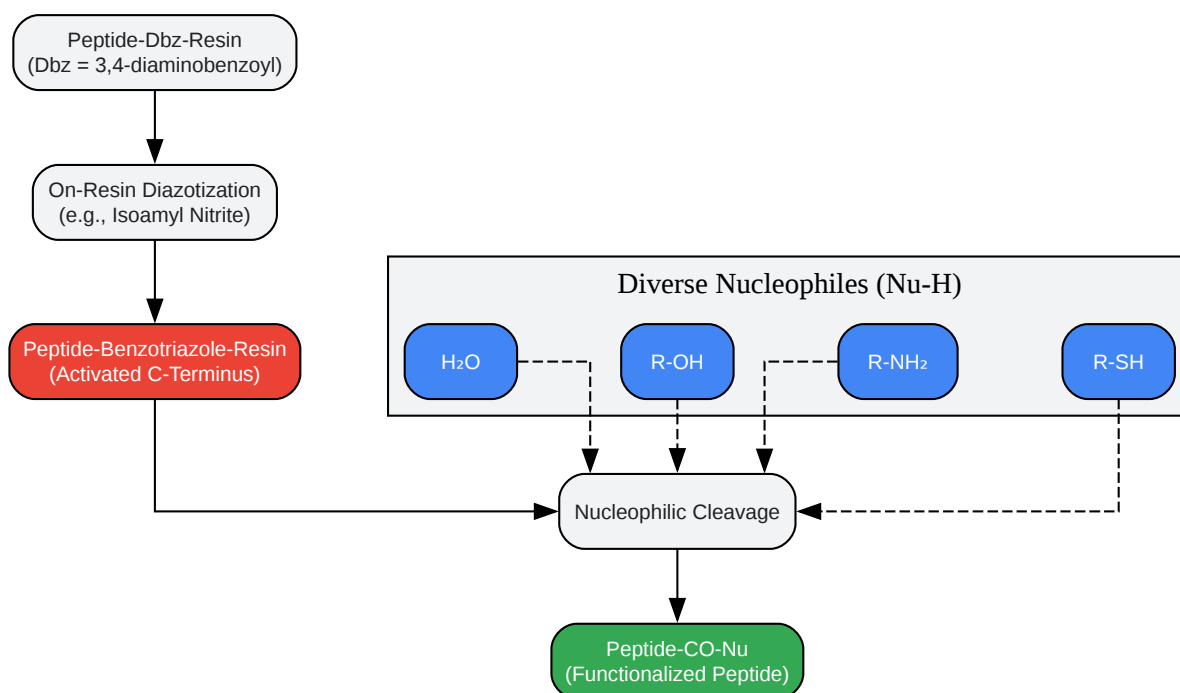

[Click to download full resolution via product page](#)

Caption: On-resin activation and nucleophilic cleavage workflow.

Experimental Protocols

The following protocols provide a generalized framework. Researchers should optimize conditions based on the specific substrate, resin, and desired product.

Protocol 1: Standard Peptide Coupling using HBTU/HOBt

This protocol outlines a typical manual solid-phase peptide synthesis (SPPS) cycle for adding one amino acid.

Materials:

- Fmoc-protected amino acid (3 eq.)

- HBTU (2.9 eq.)
- HOBt (3 eq.)
- N,N-Diisopropylethylamine (DIEA) (6 eq.)
- Resin (e.g., Rink Amide, 1 eq. substitution)
- N,N-Dimethylformamide (DMF)
- Dichloromethane (DCM)
- 20% Piperidine in DMF

Procedure:

- Resin Swelling: Swell the resin in DMF for at least 30 minutes in a reaction vessel.[12]
- Fmoc Deprotection: Drain the DMF. Add 20% piperidine in DMF to the resin and agitate for 10 minutes. Drain and repeat once.[12]
- Washing: Wash the resin thoroughly with DMF (3x), DCM (3x), and DMF (3x) to remove residual piperidine.
- Coupling Cocktail Preparation: In a separate vessel, dissolve the Fmoc-protected amino acid, HBTU, and HOBt in DMF.[12]
- Activation: Add DIEA to the coupling cocktail and allow it to pre-activate for 1-2 minutes. The solution will typically change color.[12]
- Coupling Reaction: Add the activated amino acid solution to the deprotected resin. Agitate at room temperature for 1-2 hours. Reaction completion can be monitored using a Kaiser test. [5]
- Washing: Drain the reaction vessel and wash the resin with DMF (3x) and DCM (3x). The resin is now ready for the next deprotection/coupling cycle.

Protocol 2: C-Terminal Modification via a Benzotriazole Linker

This protocol describes the final activation and cleavage steps for a peptide synthesized on a 3,4-diaminobenzoyl (Dbz) functionalized resin.

Materials:

- Peptide-Dbz-Resin (1 eq.)
- Isoamyl nitrite (10 eq.)
- Nucleophile (e.g., ethanol, benzylamine, 20 eq. in solution)
- Tetrahydrofuran (THF), anhydrous
- Dichloromethane (DCM), anhydrous

Procedure:

- Resin Preparation: Swell the dry Peptide-Dbz-Resin in anhydrous DCM for 30 minutes. Drain the solvent.
- On-Resin Activation: Add a solution of isoamyl nitrite in anhydrous THF to the resin. Agitate the suspension at room temperature for 1-2 hours. The resin may darken in color.[4][9]
- Washing: Drain the activation solution. Wash the resin with anhydrous THF (3x) and anhydrous DCM (3x) to remove excess reagents.
- Nucleophilic Cleavage: Add a solution of the chosen nucleophile (e.g., benzylamine in THF) to the activated resin. Agitate the mixture at room temperature. The reaction time can vary from 2 to 12 hours depending on the nucleophile.[9]
- Product Collection: Filter the resin and collect the filtrate. Wash the resin with additional solvent (THF or DCM) and combine the filtrates.
- Work-up: The combined filtrate contains the C-terminally modified peptide. Evaporate the solvent under reduced pressure. The crude product can then be purified by standard

methods such as HPLC. Yields for this cleavage method typically range from 66% to 82%.[4]
[9]

Data Summary: Comparative Performance

Benzotriazole-based reagents offer significant advantages in terms of reaction efficiency and product purity.

Parameter	Benzotriazole-Based (e.g., HBTU/HOBt)	Standard Carbodiimide (e.g., DCC)
Coupling Efficiency	High, especially for difficult sequences[10]	Moderate, can be problematic
Racemization	Significantly suppressed[6][7]	Higher risk without additives
Byproducts	Water-soluble (tetramethylurea)[10]	Insoluble (dicyclohexylurea)
Reaction Time	Generally faster (e.g., 30 min cycles)[10]	Slower (e.g., >60 min cycles) [10]
Cleavage Versatility	High (acids, esters, amides, etc.)[9]	Dependent on primary linker type

Table comparing the general performance of benzotriazole-based coupling reagents against standard carbodiimide methods.

Applications and Outlook

The utility of benzotriazole linkers extends beyond standard peptide synthesis. They have been successfully employed in the solid-phase synthesis of peptidols (peptide alcohols) via reductive cleavage, achieving yields of 49-87%.[1] Furthermore, polymer-supported benzotriazoles have been developed as catalysts for constructing libraries of small molecules, such as tetrahydroquinolines, where the resin can be recovered and reused without loss of activity.[8] These "traceless" linker strategies are invaluable in combinatorial chemistry and drug discovery for generating molecular diversity.[3]

The continued development of novel benzotriazole-based linkers and activating agents promises to further enhance the efficiency, scope, and versatility of solid-phase synthesis. These tools are critical for accessing complex peptides, functionalized biomolecules, and diverse heterocyclic libraries that are central to modern therapeutic and materials science research.

References

- Chen, S. H., et al. (2024). Solid-Phase Synthesis of Peptidols via Reductive Cleavage Through a Benzotriazole Linker. *Advanced Synthesis & Catalysis*. Available at: [\[Link\]](#)
- Aapptec. (n.d.). Technical Support Information Bulletin 1098 - HOBt (N-Hydroxybenzotriazole). Available at: [\[Link\]](#)
- Fields, C. G., et al. (1991). Automated Solid-Phase Peptide Synthesis: Use of Z-(1H-Benzotriazol-1-yl)
- Talukdar, S., et al. (2001). Polymer-Supported Benzotriazoles as Catalysts in the Synthesis of Tetrahydroquinolines by Condensation of Aldehydes with Aromatic Amines. *Journal of Combinatorial Chemistry*, 3(4), 341-345. Available at: [\[Link\]](#)
- Chuang, H. Y., et al. (2017). Expedient on-resin modification of a peptide C-terminus through a benzotriazole linker. *Chemical Science*, 8(12), 8064-8069. Available at: [\[Link\]](#)
- Pharmaffiliates. (2026). Understanding HOBt Hydrate: Properties and Applications for Chemists. Available at: [\[Link\]](#)
- Royal Society of Chemistry. (2017). Expedient on-resin modification of a peptide C-terminus through a benzotriazole linker. *Chemical Science*. Available at: [\[Link\]](#)
- Damschroder, R. E., & Peterson, W. D. (1940). 1,2,3-BENZOTRIAZOLE. *Organic Syntheses*, 20, 16. Available at: [\[Link\]](#)
- National Yang Ming Chiao Tung University. (n.d.). Solid-Phase Synthesis of Peptidols via Reductive Cleavage Through a Benzotriazole Linker - Fingerprint. Academic Hub.
- ChemRxiv. (n.d.). The Breaking Beads Approach for Photocleavage from Solid Support. Available at: [\[Link\]](#)

- Katritzky, A. R., et al. (2009). Benzotriazole-assisted solid-phase assembly of Leu-enkephalin, amyloid beta segment 34-42, and other "difficult" peptide sequences. *The Journal of Organic Chemistry*, 74(5), 2028-32. Available at: [\[Link\]](#)
- National Center for Biotechnology Information. (n.d.). The Mechanism of Rh(I)-Catalyzed Coupling of Benzotriazoles and Allenes Revisited: Substrate Inhibition, Proton Shuttling, and the Role of Cationic vs Neutral Species. PubMed Central.
- James, I. W. (1999). Solid phase synthesis: designer linkers for combinatorial chemistry: a review. *Tetrahedron*, 55(16), 4855-4946.
- Scicinski, J. J., et al. (2001). Solid-Phase Development of a 1-Hydroxybenzotriazole Linker for Heterocycle Synthesis Using Analytical Constructs. *ACS Combinatorial Science*, 3(5), 456-461. Available at: [\[Link\]](#)
- Schiemann, K., & Showalter, H. D. H. (1999). Development of Polymer-Supported Benzotriazole as a Novel Traceless Linker for Solid-Phase Organic Synthesis. *The Journal of Organic Chemistry*, 64(13), 4972-4975. Available at: [\[Link\]](#)

Need Custom Synthesis?

BenchChem offers custom synthesis for rare earth carbides and specific isotopic labeling.

Email: info@benchchem.com or [Request Quote Online](#).

Sources

- 1. [researchgate.net](https://www.researchgate.net) [[researchgate.net](https://www.researchgate.net)]
- 2. [semanticscholar.org](https://www.semanticscholar.org) [[semanticscholar.org](https://www.semanticscholar.org)]
- 3. pubs.acs.org [pubs.acs.org]
- 4. Expedient on-resin modification of a peptide C-terminus through a benzotriazole linker - *Chemical Science* (RSC Publishing) DOI:10.1039/C7SC03229C [pubs.rsc.org]
- 5. [peptide.com](https://www.peptide.com) [[peptide.com](https://www.peptide.com)]
- 6. [nbinno.com](https://www.nbinno.com) [[nbinno.com](https://www.nbinno.com)]
- 7. The Role of HOBt and HBTU in Peptide Coupling Reactions - *Creative Peptides* [[creative-peptides.com](https://www.creative-peptides.com)]

- [8. scispace.com \[scispace.com\]](https://scispace.com)
- [9. Expedient on-resin modification of a peptide C-terminus through a benzotriazole linker - Chemical Science \(RSC Publishing\) \[pubs.rsc.org\]](#)
- [10. luxembourg-bio.com \[luxembourg-bio.com\]](https://luxembourg-bio.com)
- [11. Exploring the Diverse Functions of HBTU in Peptide Synthesis \[en.highfine.com\]](https://en.highfine.com)
- [12. pdf.benchchem.com \[pdf.benchchem.com\]](https://pdf.benchchem.com)
- [13. Benzotriazole-assisted solid-phase assembly of Leu-enkephalin, amyloid beta segment 34-42, and other "difficult" peptide sequences - PubMed \[pubmed.ncbi.nlm.nih.gov\]](#)
- To cite this document: BenchChem. [Application Notes & Protocols: Solid-Phase Synthesis Using Benzotriazole Linkers]. BenchChem, [2026]. [Online PDF]. Available at: [\[https://www.benchchem.com/product/b1143282/docs#application-notes-protocols-solid-phase-synthesis-using-benzotriazole-linkers\]](https://www.benchchem.com/product/b1143282/docs#application-notes-protocols-solid-phase-synthesis-using-benzotriazole-linkers)

Disclaimer & Data Validity:

The information provided in this document is for Research Use Only (RUO) and is strictly not intended for diagnostic or therapeutic procedures. While BenchChem strives to provide accurate protocols, we make no warranties, express or implied, regarding the fitness of this product for every specific experimental setup.

Technical Support: The protocols provided are for reference purposes. Unsure if this reagent suits your experiment?

Need Industrial/Bulk Grade? [Request Custom Synthesis Quote](#)

BenchChem

Our mission is to be the trusted global source of essential and advanced chemicals, empowering scientists and researchers to drive progress in science and industry.

Contact

Address: 3281 E Guasti Rd
Ontario, CA 91761, United States
Phone: (601) 213-4426
Email: info@benchchem.com

Contact our Ph.D. Support Team for a compatibility check