

# Application Notes & Protocols: Modification of Electrodes with Ferroceneacetonitrile for Advanced Sensing Applications

**Author:** BenchChem Technical Support Team. **Date:** May 2026

## Compound of Interest

Compound Name:	FERROCENEACETONITRILE
CAS No.:	1316-91-2
Cat. No.:	B1143365

[Get Quote](#)

Document ID: AN-FCAN-2026-01

## Abstract

This document provides a comprehensive technical guide for researchers, scientists, and drug development professionals on the protocols for modifying electrode surfaces with **ferroceneacetonitrile** (FcCN). Ferrocene and its derivatives are exemplary redox mediators due to their stable and reversible one-electron transfer process, making them ideal for electrochemical sensor development.<sup>[1][2]</sup> This guide details the principles behind electrode modification, step-by-step protocols for immobilization, essential characterization techniques for validation, and a foundational protocol for a sensing application. The causality behind experimental choices is emphasized to ensure both reproducibility and a deep understanding of the underlying electrochemical principles.

## Introduction: The Role of Ferrocene in Electrochemical Sensing

Ferrocene (Fc) is a cornerstone organometallic compound in electrochemical research, prized for its remarkable redox properties and structural versatility.[1][2] It undergoes a highly reversible one-electron oxidation from the neutral ferrocene (Fc) state to the ferrocenium cation (Fc<sup>+</sup>), a process that is typically stable and pH-independent.[3] This predictable electrochemical behavior allows it to serve as an efficient and adaptable redox-active center in sensor design.[1]

By immobilizing ferrocene derivatives onto an electrode surface, we can create a "smart" interface where the electron transfer properties of ferrocene can be modulated by the presence of a target analyte. This interaction forms the basis of a highly sensitive sensing platform.

**Ferroceneacetonitrile** is a particularly interesting derivative for this purpose. The terminal nitrile (-C≡N) group is a versatile chemical handle; it can potentially be used for direct electrochemical grafting or serve as a precursor for further functionalization (e.g., hydrolysis to a carboxylic acid or reduction to an amine), enabling the covalent attachment of biorecognition elements like enzymes or antibodies.

## Foundational Principles of Electrode Modification

The goal of electrode modification is to create a stable, electroactive film on the electrode surface. The choice of method depends on the electrode material (e.g., Gold, Platinum, Glassy Carbon) and the desired film characteristics (e.g., monolayer vs. polymer, covalent vs. non-covalent attachment).

- **Electrografting:** This technique involves the electrochemical oxidation or reduction of a precursor molecule to generate a reactive radical species.[4] This radical then forms a direct, robust covalent bond with the electrode surface. This method is particularly effective for carbon-based electrodes.[5]
- **Electropolymerization:** Certain ferrocene derivatives can be functionalized with polymerizable groups (like pyrrole or thiophene).[1] By applying a specific potential, these monomers can be polymerized directly onto the electrode surface, entrapping the ferrocene redox center within a conductive polymer matrix.[1]
- **Self-Assembled Monolayers (SAMs):** While classic for thiol-on-gold chemistry, the principle of forming organized monolayers is a key concept.[6] Dilute ferrocene surfaces are often

used to minimize intermolecular interactions that can complicate the electrochemical response.<sup>[7]</sup>

This guide will focus on the electrografting approach via cyclic voltammetry, as it provides a direct and controllable method for creating a covalently attached film of **ferroceneacetonitrile**.

## Experimental Workflow and Logic

The successful development of a ferrocene-modified sensor follows a logical progression of steps, each critical for the final performance. This workflow ensures that the modification is successful and the resulting sensor is well-characterized before use.

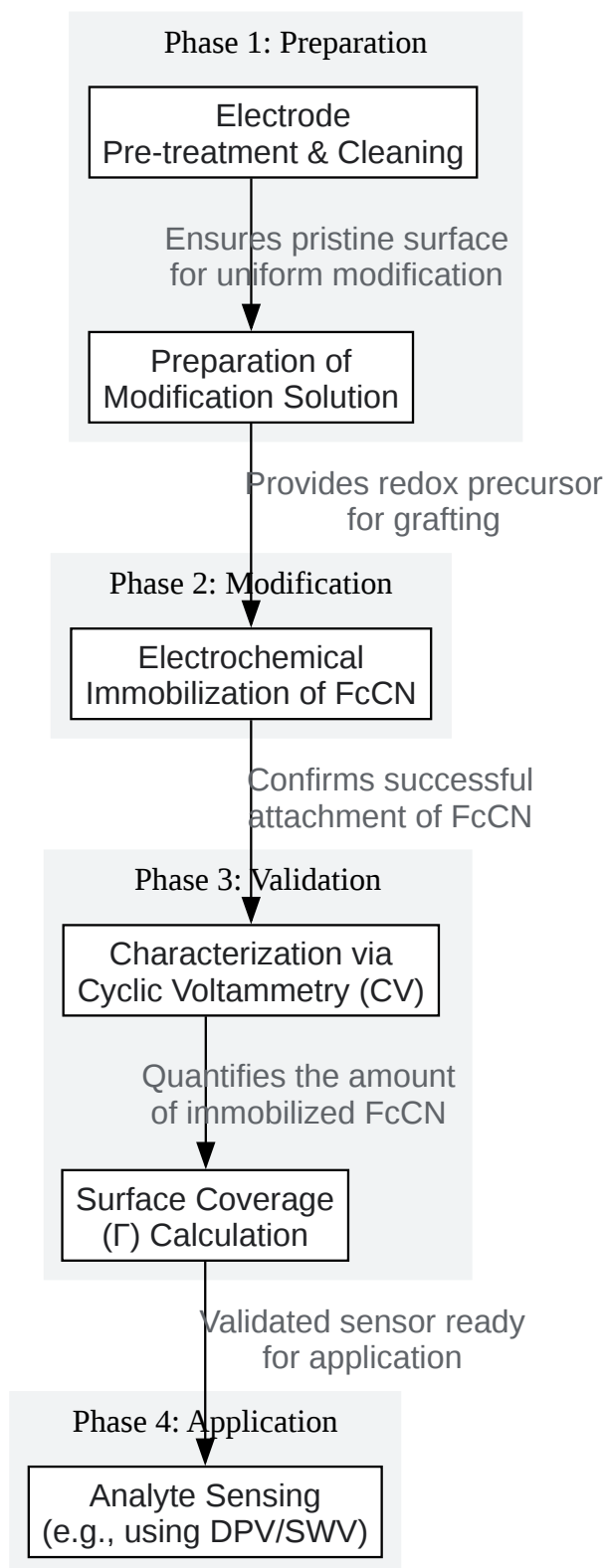

[Click to download full resolution via product page](#)

Caption: Workflow for Ferrocene-Modified Electrode Sensor Development.

## Detailed Protocols

### Materials and Reagents

Reagent / Material	Specification	Supplier Example	Purpose
Glassy Carbon Electrode (GCE)	3 mm diameter	CH Instruments, Inc.	Working Electrode
Platinum Wire	99.9% purity	Sigma-Aldrich	Counter Electrode
Ag/AgCl Electrode	3M KCl filling solution	BASi	Reference Electrode
Ferroceneacetonitrile (FcCN)	>98% purity	Sigma-Aldrich	Redox Mediator
Acetonitrile (MeCN)	Anhydrous, >99.8%	Sigma-Aldrich	Solvent
Tetrabutylammonium Hexafluorophosphate (TBAPF <sub>6</sub> )	Electrochemical grade, >99%	Sigma-Aldrich	Supporting Electrolyte
Alumina Slurry	0.3 μm and 0.05 μm	Buehler	Polishing Agent
Deionized (DI) Water	18.2 MΩ·cm	Millipore System	Rinsing
Ethanol	ACS Grade	Fisher Scientific	Rinsing / Degreasing

## Protocol 1: Glassy Carbon Electrode (GCE) Pre-treatment

Causality: A pristine, atomically smooth electrode surface is paramount for achieving a uniform and reproducible ferrocene film. Any surface contamination or defects will lead to inconsistent grafting and poor electrochemical performance. This multi-step polishing and cleaning procedure is designed to remove organic and inorganic residues and to electrochemically activate the carbon surface.

- Mechanical Polishing:
  - Place a small amount of 0.3 μm alumina slurry onto a polishing pad.
  - Polish the GCE surface in a figure-eight motion for 5 minutes.

- Rinse the electrode thoroughly with DI water.
- Repeat the process with 0.05  $\mu\text{m}$  alumina slurry for 5 minutes.
- Sonication Cleaning:
  - Sonicate the polished electrode in DI water for 3 minutes to remove any embedded alumina particles.
  - Sonicate in ethanol for 3 minutes to degrease the surface.
  - Rinse thoroughly with DI water and dry under a gentle stream of nitrogen.
- Electrochemical Activation (Optional but Recommended):
  - In a 0.5 M  $\text{H}_2\text{SO}_4$  solution, cycle the potential between -0.2 V and +1.2 V (vs. Ag/AgCl) at a scan rate of 100 mV/s for 20 cycles. This process electrochemically cleans and creates active functional groups on the carbon surface.[6]
  - Rinse the electrode extensively with DI water and dry with nitrogen. The electrode is now ready for modification.

## Protocol 2: Electrochemical Modification with Ferroceneacetonitrile

Causality: This protocol utilizes cyclic voltammetry to electrograft FcCN onto the GCE. By repeatedly cycling the potential, we can control the formation of the surface film. Anhydrous acetonitrile is used as the solvent because protic solvents (like water) can interfere with the radical formation needed for grafting.[4][5] TBAPF<sub>6</sub> is a common supporting electrolyte that is electrochemically stable over a wide potential window.[8]

- Prepare Modification Solution:
  - In a glovebox or dry environment, prepare a solution of 2 mM **Ferroceneacetonitrile** and 0.1 M TBAPF<sub>6</sub> in anhydrous acetonitrile.
- Electrochemical Setup:

- Assemble a three-electrode cell with the pre-treated GCE as the working electrode, a platinum wire as the counter electrode, and Ag/AgCl as the reference electrode.
- Add the modification solution to the cell and purge with nitrogen for 10 minutes to remove dissolved oxygen. Maintain a nitrogen blanket over the solution during the experiment.
- Electrografting Procedure:
  - Set the potential window of the potentiostat from 0 V to +0.8 V (vs. Ag/AgCl). Note: This window should bracket the oxidation potential of the ferrocene derivative.
  - Set the scan rate to 100 mV/s.
  - Run the cyclic voltammetry for 15-20 cycles.
  - You should observe a gradual increase in the peak currents of the ferrocene/ferrocenium redox couple with each cycle, indicating the progressive buildup of the electroactive film on the electrode surface.
- Post-Modification Cleaning:
  - After cycling, remove the electrode from the modification solution.
  - Rinse it thoroughly with pure acetonitrile to remove any non-covalently attached (physisorbed) molecules.
  - Dry the electrode under a nitrogen stream. It is now a FcCN-modified electrode (GCE-FcCN).

## Protocol Validation and Characterization

Causality: Characterization is a self-validating step to confirm that the modification was successful and to quantify the properties of the resulting film. This is crucial for ensuring sensor-to-sensor reproducibility.

## Protocol 3: CV Characterization of the GCE-FcCN

- Prepare Characterization Solution: Prepare a fresh solution containing only 0.1 M TBAPF<sub>6</sub> in anhydrous acetonitrile. This is a "blank" solution without the ferrocene precursor.
- Run CV:
  - Place the GCE-FcCN in the blank electrolyte solution.
  - Run a cyclic voltammogram from 0 V to +0.8 V at various scan rates (e.g., 20, 50, 100, 150, 200 mV/s).
- Analyze the Data:
  - Confirmation of Immobilization: A well-defined, quasi-reversible redox wave corresponding to the Fc/Fc<sup>+</sup> couple should be observed.[6] Unlike a solution-phase species, the peak shape should be symmetrical.
  - Stability Test: Run the CV for 50-100 continuous cycles. A stable film should show minimal decrease (<5-10%) in peak current, demonstrating robust attachment.[8]
  - Scan Rate Dependence: Plot the anodic peak current ( $I_{pa}$ ) versus the scan rate ( $v$ ). For a surface-immobilized species, this relationship should be linear ( $I_{pa} \propto v$ ). In contrast, for a species diffusing from solution, it would be linear with the square root of the scan rate ( $I_{pa} \propto v^{1/2}$ ). This test definitively proves surface confinement.

Parameter	Ideal Result for Surface-Bound Ferrocene	Interpretation
Peak Shape	Symmetrical anodic and cathodic peaks	Indicates a stable, surface-confined redox species.
Peak Separation ( $\Delta E_p$ )	Close to 0 mV (ideally $< 90.6/n$ mV)	A small $\Delta E_p$ suggests fast, reversible electron transfer kinetics.[6]
$I_{pa} / I_{pc}$ Ratio	Approximately 1	Indicates chemical reversibility of the redox process.
Peak Current ( $I_p$ ) vs. Scan Rate ( $v$ )	Linear Relationship ( $I_p \propto v$ )	Confirms that the redox species is attached to the surface.

## Calculation of Surface Coverage ( $\Gamma$ )

The surface coverage ( $\Gamma$ , in mol/cm<sup>2</sup>) is the amount of electroactive ferrocene immobilized per unit area of the electrode. It can be calculated from the CV data using the Laviron equation, which for a surface-controlled process simplifies to the integration of the peak area.

Formula:  $\Gamma = Q / (nFA)$

Where:

- Q is the charge consumed in the oxidation or reduction, calculated by integrating the area under the anodic or cathodic peak (in Coulombs).
- n is the number of electrons transferred (n=1 for ferrocene).
- F is the Faraday constant (96485 C/mol).
- A is the geometric area of the electrode (for a 3 mm diameter GCE, A = 0.0707 cm<sup>2</sup>).

A typical surface coverage for a monolayer is in the range of 10<sup>-10</sup> to 10<sup>-9</sup> mol/cm<sup>2</sup>. [6]

## Application in Electrochemical Sensing

The GCE-FcCN can now be used as a sensor. The principle relies on the interaction between the analyte and the ferrocene moiety, which causes a measurable change in the electrochemical signal.

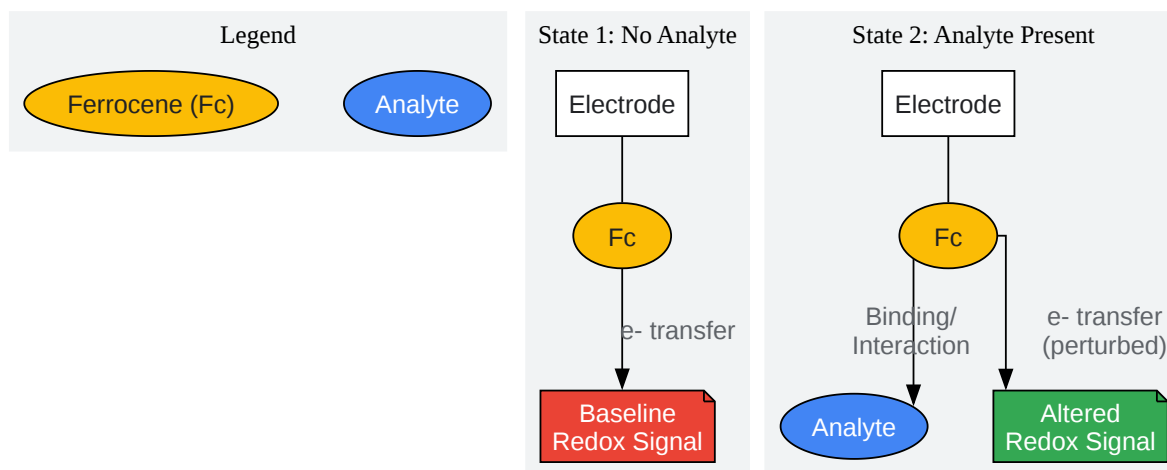

[Click to download full resolution via product page](#)

Caption: Principle of Sensing via Ferrocene Signal Modulation.

## Protocol 4: General Analyte Detection

**Causality:** This protocol uses Differential Pulse Voltammetry (DPV), a more sensitive technique than CV, to measure the sensor's response. DPV minimizes the background (capacitive) current, resulting in a higher signal-to-noise ratio and lower detection limits. The change in the ferrocene peak current or potential upon addition of the analyte is used for quantification.

- **Prepare Buffer/Electrolyte:** Choose a buffer system appropriate for your analyte (e.g., Phosphate-Buffered Saline for biological samples, or 0.1 M TBAPF<sub>6</sub> in acetonitrile for organic analysis).
- **Establish Baseline:**

- Place the validated GCE-FcCN into the analyte-free buffer.
- Run a DPV scan across the potential range of the ferrocene redox couple (e.g., 0 V to +0.8 V).
- Record the peak current ( $I_0$ ) and peak potential ( $E_0$ ) of the ferrocene signal.
- Analyte Measurement:
  - Add a known concentration of the analyte to the cell and stir for a defined incubation time (e.g., 2-5 minutes) to allow for interaction with the surface.
  - Stop the stirring and allow the solution to become quiescent.
  - Run a new DPV scan and record the new peak current ( $I$ ) and potential ( $E$ ).
- Data Analysis:
  - The sensor response can be quantified as the change in current ( $\Delta I = I - I_0$ ) or the shift in potential ( $\Delta E = E - E_0$ ).
  - To create a calibration curve, repeat step 3 with increasing concentrations of the analyte. Plot the sensor response (e.g.,  $\Delta I$ ) versus the analyte concentration.

## References

- Title: Electrochemistry of Redox Active Ferrocene Covalently Attached to Glassy Carbon  
Source: OSTI.GOV URL:[[Link](#)]
- Title: Tunable Redox Potential, Optical Properties, and Enhanced Stability of Modified Ferrocene-Based Complexes  
Source: PMC (ACS Omega) URL:[[Link](#)]
- Title: Cyclic voltammetry behavior of 2 mM ferrocene in acetonitrile+0.1 M...  
Source: ResearchGate URL:[[Link](#)]
- Title: Mechanistic Insights of Cycling Stability of Ferrocene Catholytes in Aqueous Redox Flow Batteries  
Source: American Chemical Society URL:[[Link](#)]

- Title: Cyclic voltammetry of 2 mM ferrocene in acetonitrile on polished (A)... Source: ResearchGate URL:[[Link](#)]
- Title: Beyond Cations: Expanding the Horizons of Ferrocene-Based Electrochemical Sensors for Neutral and Anionic Molecules Source: MDPI (Chemosensors) URL:[[Link](#)]
- Title: Research Report on Recent Applications of Ferrocene Derivatives Based Electrochemical Immunosensors Using Nanomaterials Source: RSIS International URL:[[Link](#)]
- Title: Probing the Surface Structure of Ferrocene Modified Electrodes using Cyclic Voltammetry Source: RAISE URL:[[Link](#)]
- Title: Ferrocene-Based Electrochemical Sensors for Cations Source: MDPI (Chemosensors) URL:[[Link](#)]
- Title: An Electrochemical Evaluation of Novel Ferrocene Derivatives for Glutamate and Liver Biomarker Biosensing Source: MDPI (Biosensors) URL:[[Link](#)]
- Title: Electrochemical impedance spectroscopy and cyclic voltammetry of ferrocene in acetonitrile/acetone system Source: ResearchGate URL:[[Link](#)]

### *Need Custom Synthesis?*

*BenchChem offers custom synthesis for rare earth carbides and specific isotopic labeling.*

*Email: [info@benchchem.com](mailto:info@benchchem.com) or [Request Quote Online](#).*

## Sources

- 1. [mdpi.com](https://www.mdpi.com) [[mdpi.com](https://www.mdpi.com)]
- 2. [rsisinternational.org](https://www.rsisinternational.org) [[rsisinternational.org](https://www.rsisinternational.org)]
- 3. [mdpi.com](https://www.mdpi.com) [[mdpi.com](https://www.mdpi.com)]
- 4. [researchgate.net](https://www.researchgate.net) [[researchgate.net](https://www.researchgate.net)]
- 5. [researchgate.net](https://www.researchgate.net) [[researchgate.net](https://www.researchgate.net)]
- 6. [osti.gov](https://www.osti.gov) [[osti.gov](https://www.osti.gov)]

- [7. researchgate.net \[researchgate.net\]](https://www.researchgate.net)
- [8. Tunable Redox Potential, Optical Properties, and Enhanced Stability of Modified Ferrocene-Based Complexes - PMC \[pmc.ncbi.nlm.nih.gov\]](https://pubmed.ncbi.nlm.nih.gov/)
- To cite this document: BenchChem. [Application Notes & Protocols: Modification of Electrodes with Ferroceneacetonitrile for Advanced Sensing Applications]. BenchChem, [2026]. [Online PDF]. Available at: [\[https://www.benchchem.com/product/b1143365/docs#application-notes-protocols-modification-of-electrodes-with-ferroceneacetonitrile-for-advanced-sensing-applications\]](https://www.benchchem.com/product/b1143365/docs#application-notes-protocols-modification-of-electrodes-with-ferroceneacetonitrile-for-advanced-sensing-applications)

---

### Disclaimer & Data Validity:

The information provided in this document is for Research Use Only (RUO) and is strictly not intended for diagnostic or therapeutic procedures. While BenchChem strives to provide accurate protocols, we make no warranties, express or implied, regarding the fitness of this product for every specific experimental setup.

**Technical Support:** The protocols provided are for reference purposes. Unsure if this reagent suits your experiment?

**Need Industrial/Bulk Grade?** [Request Custom Synthesis Quote](#)

## BenchChem

Our mission is to be the trusted global source of essential and advanced chemicals, empowering scientists and researchers to drive progress in science and industry.

### Contact

Address: 3281 E Guasti Rd  
Ontario, CA 91761, United States  
Phone: (601) 213-4426  
Email: [info@benchchem.com](mailto:info@benchchem.com)

[Contact our Ph.D. Support Team for a compatibility check](#)

