

# The Dual Analytical Challenge: API Characterization vs. Impurity Profiling

**Author:** BenchChem Technical Support Team. **Date:** April 2026

## Compound of Interest

Compound Name: *3-(quinolin-2-yl)propyl Methanesulfonate*  
CAS No.: 1338247-46-3  
Cat. No.: B1141694

[Get Quote](#)

Quinoline mesylates cannot be adequately characterized by a single analytical technique. The physicochemical properties of the API and its potential impurities dictate a bifurcated MS approach:

- **API & Degradant Profiling:** The quinoline core contains a basic nitrogen (pKa ~5.05 for Lenvatinib)[2], making it highly amenable to Liquid Chromatography-Electrospray Ionization (LC-ESI-MS). Because forced degradation studies generate unknown species, High-Resolution Mass Spectrometry (HRMS) is required to deduce exact elemental compositions[3].
- **Genotoxic Impurity (PGI) Quantification:** If residual alcohols (methanol, ethanol, isopropanol) are present during the mesylate salt formation, they react with methanesulfonic acid to form methyl methanesulfonate (MMS), ethyl methanesulfonate (EMS), and isopropyl methanesulfonate (IMS)[4]. These alkyl mesylates are volatile, lack UV chromophores, and do not ionize well by ESI. Therefore, Gas Chromatography-Mass Spectrometry (GC-MS/MS) with Electron Ionization (EI) is the gold standard[5].

## Table 1: Comparison of MS Platforms for Quinoline Mesylate Workflows

Analytical Goal	Preferred Platform	Ionization	Sensitivity	Key Strengths	Limitations
API Structural Elucidation	LC-HRMS (Q-TOF / Orbitrap)	ESI (+)	High (ng/mL)	Sub-5 ppm mass accuracy; resolves complex isotopic patterns; identifies unknown degradants.	Overkill for routine batch release; high instrument cost.
Routine API Quantitation	LC-QqQ (Triple Quadrupole)	ESI (+)	Very High (pg/mL)	Maximum sensitivity for targeted pharmacokinetics; wide linear dynamic range.	Cannot identify unknown degradation products.
Alkyl Mesylate (PGI) Analysis	GC-MS/MS (Triple Quadrupole)	EI (70 eV)	Ultra-High (ng/g or ppb)	Excellent volatility match; avoids matrix suppression; meets strict ICH M7 TTC limits.	Requires sample extraction (LLE) to prevent API from fouling the GC inlet.

## Workflow A: API Structural Elucidation & Forced Degradation

To understand the stability of a quinoline mesylate, we subject it to forced degradation (acidic, basic, oxidative, and thermal stress)[6]. The goal is to separate the resulting degradants via Ultra-High-Performance Liquid Chromatography (UHPLC) and identify them using HRMS.

Mechanistic Insight: Why ESI Positive Mode? The basic nitrogen in the quinoline ring readily accepts a proton. By utilizing an acidic mobile phase (e.g., 0.1% formic acid, pH ~2.7), we ensure the quinoline nitrogen is fully ionized as  $[M+H]^+$ , maximizing signal intensity and promoting predictable collision-induced dissociation (CID) pathways[7].

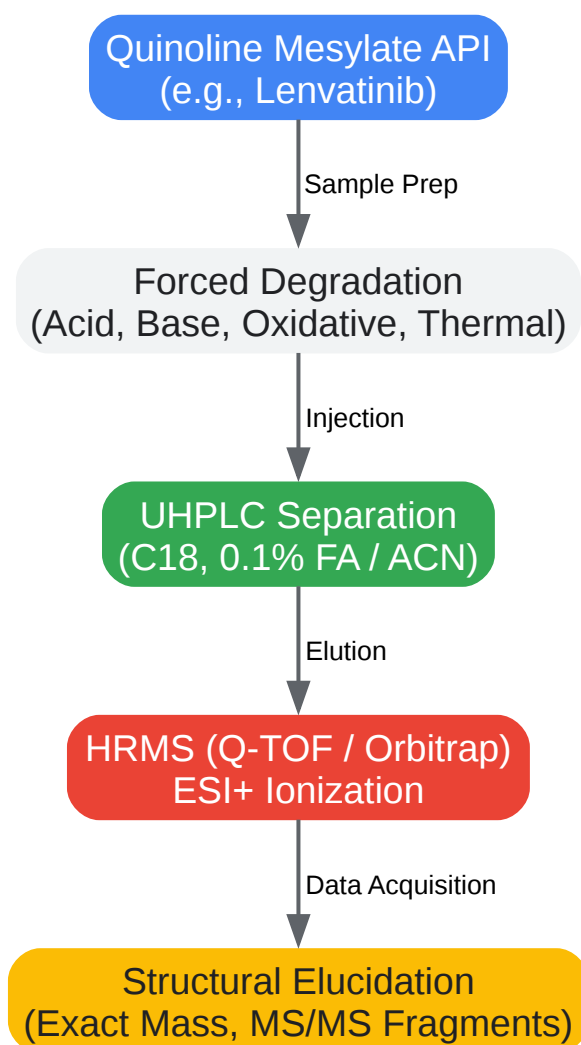

[Click to download full resolution via product page](#)

Workflow for structural elucidation and forced degradation profiling of quinoline mesylate APIs.

## Protocol: LC-HRMS Characterization of Lenvatinib Mesylate Degradants

- Sample Preparation: Dissolve the API in a diluent of Water:Acetonitrile (50:50 v/v) to a concentration of 100 µg/mL.
- Forced Degradation: For acid hydrolysis, add 1N HCl and heat at 60°C for 24 hours. Neutralize with 1N NaOH prior to injection to protect the analytical column[8].
- Chromatography:
  - Column: Sub-2 µm C18 column (e.g., 100 mm × 2.1 mm, 1.8 µm).
  - Mobile Phase A: 0.1% Formic Acid in Water.
  - Mobile Phase B: 0.1% Formic Acid in Acetonitrile.
  - Gradient: 5% B to 95% B over 15 minutes at 0.3 mL/min.
- HRMS Acquisition: Operate the Q-TOF or Orbitrap in positive ESI mode. Set the capillary voltage to 3.5 kV. Acquire full scan MS data (m/z 100–1000) at high resolution (>60,000 FWHM). Use Data-Dependent Acquisition (DDA) to trigger MS/MS fragmentation on the top 5 most abundant precursor ions.
- Data Interpretation: Calculate the exact mass of degradant peaks. Mass errors must be < 5 ppm. Use the MS/MS spectra to map cleavage sites (e.g., cleavage of the urea linkage or ether bonds common in quinoline derivatives)[3].

## Workflow B: Trace Quantification of Alkyl Mesylates (PGIs)

Regulatory agencies require that genotoxic impurities be controlled to a Threshold of Toxicological Concern (TTC), often limiting intake to <1.5 µg/day [9]. For a typical API dose, this requires limits of quantitation (LOQ) in the low parts-per-million (ppm) or parts-per-billion (ppb) range.

Mechanistic Insight: Why Liquid-Liquid Extraction (LLE) prior to GC-MS? Injecting a bulk quinoline mesylate salt directly into a GC would instantly foul the heated inlet and degrade the stationary phase. We exploit the differential solubility of the analytes. The highly polar API salt remains in the aqueous phase, while the volatile, neutral alkyl mesylates (MMS, EMS, IMS) partition efficiently into a dense organic solvent like dichloromethane (DCM)[4].

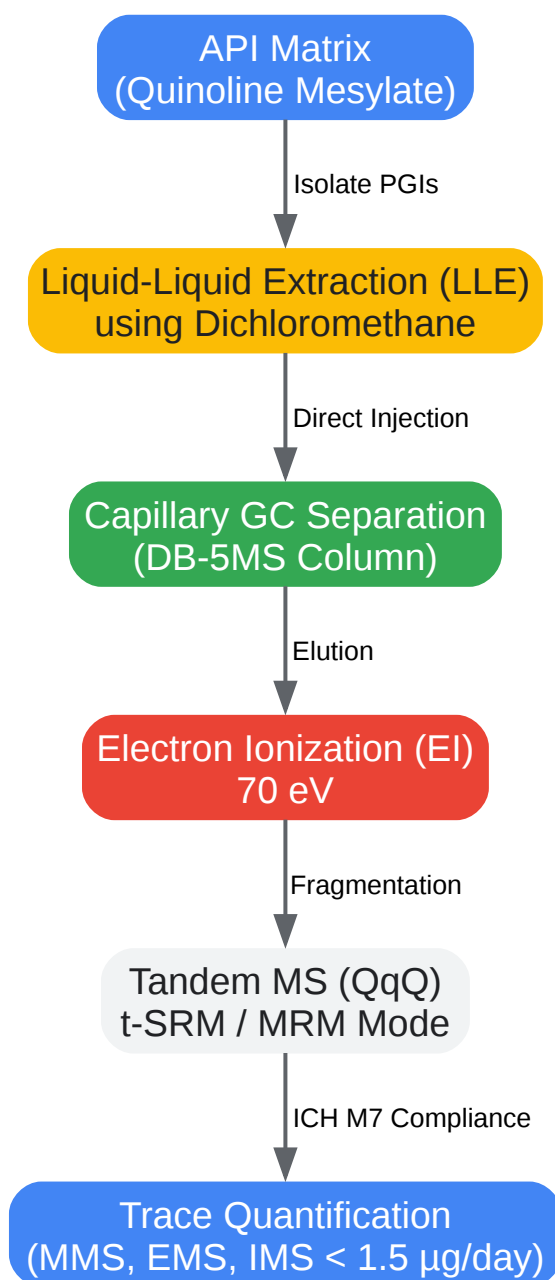

[Click to download full resolution via product page](#)

GC-MS/MS workflow utilizing liquid-liquid extraction for trace quantification of alkyl mesylates.

## Protocol: GC-MS/MS Quantification of Alkyl Mesylates

- Sample Extraction (Self-Validating Step): Dissolve 100 mg of the quinoline mesylate API in 0.5 mL of purified water. Add 1.0 mL of Dichloromethane (DCM) containing an internal standard (e.g., deuterated MMS-d3). Vortex vigorously for 2 minutes to ensure complete partitioning. Centrifuge to separate the layers. The dense lower DCM layer contains the PGIs[4].
- GC Separation:
  - Column: DB-5MS (30 m × 0.25 mm × 0.25 μm)[9].
  - Injection: 2 μL splitless injection at 200°C.
  - Oven Program: Hold at 40°C for 2 min, ramp at 10°C/min to 150°C, then 30°C/min to 280°C to bake out any residual matrix.
- MS/MS Detection:
  - Ionization: Electron Ionization (EI) at 70 eV.
  - Acquisition: Time-dependent Selected Reaction Monitoring (t-SRM).
  - Transitions: Monitor specific fragmentations, such as m/z 110 → 79 for MMS and m/z 124 → 79 for EMS. The m/z 79 ion corresponds to the [CH3SO2]<sup>+</sup> fragment, a universal marker for methanesulfonates[10].
- Validation: Ensure the calibration curve is linear ( R<sup>2</sup>>0.999 ) from 1 to 50 ng/mL, with spike recoveries between 90-110% to confirm the absence of matrix effects[5].

## Conclusion

The comprehensive characterization of quinoline mesylate derivatives demands a hybrid analytical strategy. LC-HRMS provides the necessary resolving power and mass accuracy to elucidate complex API degradation pathways, while GC-MS/MS coupled with targeted liquid-liquid extraction remains the unrivaled choice for isolating and quantifying volatile genotoxic impurities. By understanding the physicochemical causality behind these methods, analytical

scientists can build robust, self-validating workflows that ensure both drug efficacy and patient safety.

### *Need Custom Synthesis?*

*BenchChem offers custom synthesis for rare earth carbides and specific isotopic labeling.*

*Email: [info@benchchem.com](mailto:info@benchchem.com) or [Request Quote Online](#).*

## Sources

- [1. Validated GC-MS and LC-MS/MS Methods for ICH M7-Based Quantification of Alkyl Mesylate and Azido Genotoxic Impurities in Pharmaceutical Products - PubMed \[pubmed.ncbi.nlm.nih.gov\]](#)
- [2. scispace.com \[scispace.com\]](#)
- [3. researchgate.net \[researchgate.net\]](#)
- [4. d-nb.info \[d-nb.info\]](#)
- [5. Simultaneous determination of alkyl mesitates and alkyl besitates in finished drug products by direct injection GC/MS - PubMed \[pubmed.ncbi.nlm.nih.gov\]](#)
- [6. assets-eu.researchsquare.com \[assets-eu.researchsquare.com\]](#)
- [7. Time-of-flight accurate mass spectrometry identification of quinoline alkaloids in honey - PubMed \[pubmed.ncbi.nlm.nih.gov\]](#)
- [8. Advancing Quality and Environmental Responsibility: A Stability-Indicating LC Method Development for Lenvatinib through... \[ouci.dntb.gov.ua\]](#)
- [9. researchgate.net \[researchgate.net\]](#)
- [10. chromatographyonline.com \[chromatographyonline.com\]](#)
- [To cite this document: BenchChem. \[The Dual Analytical Challenge: API Characterization vs. Impurity Profiling\]. BenchChem, \[2026\]. \[Online PDF\]. Available at: \[https://www.benchchem.com/product/b1141694/docs#the-dual-analytical-challenge-api-characterization-vs-impurity-profiling\]](#)

---

### Disclaimer & Data Validity:

The information provided in this document is for Research Use Only (RUO) and is strictly not intended for diagnostic or therapeutic procedures. While BenchChem strives to provide accurate protocols, we make no warranties, express or implied, regarding the fitness of this product for every specific experimental setup.

**Technical Support:** The protocols provided are for reference purposes. Unsure if this reagent suits your experiment?

**Need Industrial/Bulk Grade?** [Request Custom Synthesis Quote](#)

## BenchChem

Our mission is to be the trusted global source of essential and advanced chemicals, empowering scientists and researchers to drive progress in science and industry.

### Contact

Address: 3281 E Guasti Rd  
Ontario, CA 91761, United States  
Phone: (601) 213-4426  
Email: [info@benchchem.com](mailto:info@benchchem.com)

[Contact our Ph.D. Support Team for a compatibility check](#)