

Technical Support Center: Optimizing D149 Dye Performance with Chenodeoxycholic acid (CDCA)

Author: BenchChem Technical Support Team. **Date:** April 2026

Compound of Interest

Compound Name: D149 Dye

Cat. No.: B1141169

[Get Quote](#)

This technical support center provides researchers, scientists, and drug development professionals with comprehensive troubleshooting guides and frequently asked questions (FAQs) for experiments involving the **D149 dye** and chenodeoxycholic acid (CDCA) in dye-sensitized solar cells (DSSCs).

Troubleshooting Guide

This guide addresses common issues encountered during the fabrication and testing of DSSCs using the **D149 dye** in conjunction with CDCA.

Issue	Potential Cause	Recommended Solution
Low Power Conversion Efficiency (PCE)	Dye aggregation on the TiO ₂ surface, leading to inefficient electron injection.[1][2][3]	Introduce CDCA as a co-adsorbent in the dye solution to mitigate aggregation.[1][2][3] The typical concentration of the co-adsorbent is 10 times that of the dye.[4]
Inadequate dye loading on the TiO ₂ photoanode.	Optimize the dye staining time. Be aware that prolonged immersion can sometimes lead to aggregation.	
High concentration of CDCA leading to competitive adsorption.[5]	Systematically vary the concentration of CDCA to find the optimal ratio with the D149 dye. High concentrations of CDCA can displace the dye from the TiO ₂ surface, reducing light absorption.[5][6]	
Low Short-Circuit Current (Jsc)	Poor light harvesting due to dye aggregation or insufficient dye coverage.[3]	Use CDCA to prevent dye aggregation.[3] Ensure optimal dye loading by adjusting the staining time and dye solution concentration.
Inefficient electron injection from the dye's excited state to the TiO ₂ conduction band.	The presence of CDCA can improve electron injection efficiency by preventing the formation of non-injecting dye aggregates.[7]	
Low Open-Circuit Voltage (Voc)	Increased charge recombination at the TiO ₂ /dye/electrolyte interface.	The addition of CDCA can passivate the TiO ₂ surface, reducing charge recombination and thereby increasing the Voc.[7]

Reduced Fill Factor (FF)	High series resistance within the cell.	Ensure good contact between all layers of the DSSC. Optimize the thickness and quality of the TiO ₂ film and the counter electrode.
Color change or degradation of the dye solution	Isomerization of the D149 dye upon exposure to light, particularly UV.[8]	Prepare fresh dye solutions and minimize their exposure to light before use. Store dye solutions in the dark.

Frequently Asked Questions (FAQs)

Q1: What is the primary role of chenodeoxycholic acid (CDCA) when used with **D149 dye** in a DSSC?

A1: The primary role of CDCA is to act as a co-adsorbent or anti-aggregation agent.[2][4] It is added to the dye solution to prevent the **D149 dye** molecules from clumping together (aggregating) on the surface of the TiO₂ photoanode. This prevention of aggregation leads to a more efficient electron injection from the dye to the semiconductor, thereby improving the overall performance of the solar cell.[1][7]

Q2: How does dye aggregation negatively affect the performance of a DSSC?

A2: Dye aggregation is detrimental to DSSC performance because it can lead to the quenching of the dye's excited state. This means that instead of injecting an electron into the TiO₂ conduction band, the excited dye molecule deactivates through non-radiative pathways, thus reducing the photocurrent.[3] Aggregation can also block the pores of the TiO₂ film, hindering the diffusion of the electrolyte.

Q3: What is a typical concentration ratio of **D149 dye** to CDCA in the staining solution?

A3: A common starting point for the concentration of CDCA is a 10-fold excess compared to the dye concentration.[4] However, the optimal ratio can vary depending on the specific experimental conditions, such as the solvent used and the desired dye loading. It is recommended to perform an optimization study by varying the CDCA concentration to achieve the best device performance.[9]

Q4: Can using too much CDCA be detrimental to the DSSC performance?

A4: Yes, an excessively high concentration of CDCA can negatively impact the performance of the DSSC.[5][6] This is because CDCA competes with the **D149 dye** for adsorption sites on the TiO₂ surface.[5] If too much CDCA is present, it can significantly reduce the amount of dye adsorbed, leading to lower light absorption and a decreased short-circuit current (J_{sc}).

Q5: What solvents are suitable for preparing the D149 and CDCA staining solution?

A5: Solvents such as ethanol, acetonitrile, or a mixture of ethanol and tetrahydrofuran (THF) are commonly used for preparing staining solutions for organic dyes like D149.[1] The choice of solvent can influence the solubility of both the dye and CDCA, as well as the dye adsorption process.

Quantitative Data Summary

The following table summarizes the effect of CDCA on the performance parameters of DSSCs sensitized with indoline dyes, including D149.

Dye	CDCA Concentration	J _{sc} (mA/cm ²)	V _{oc} (V)	FF	PCE (%)	Reference
D149	Without CDCA	-	-	-	6.67	[7]
D149	With CDCA	-	-	-	7.72 (15.74% increase)	[7]
DN-F05	0 mM	-	-	-	1.974	[5]
DN-F05	7.5 mM	8.35	0.689	-	2.988	[5]
P2	0 mM	9.57	0.697	0.66	4.42	[7]
P2	10 mM	10.36	0.730	0.70	5.31	[7]

Note: The specific performance parameters can vary significantly based on the complete experimental conditions, including the TiO₂ film thickness, electrolyte composition, and counter electrode material.

Experimental Protocols

Detailed Methodology for DSSC Fabrication with D149 and CDCA

This protocol outlines the key steps for fabricating a dye-sensitized solar cell using **D149 dye** and CDCA as a co-adsorbent.

- Preparation of TiO₂ Photoanode:
 - Clean a fluorine-doped tin oxide (FTO) coated glass substrate by sonication in a sequence of detergent, deionized water, acetone, and isopropanol.
 - Deposit a compact blocking layer of TiO₂ on the FTO glass by a method such as spin coating or spray pyrolysis.
 - Deposit a mesoporous TiO₂ layer (nanoparticle paste) on top of the blocking layer using a technique like screen printing or doctor-blading.
 - Sinter the TiO₂-coated FTO glass at a high temperature (e.g., 450-500 °C) to ensure good particle necking and remove organic binders.
 - Allow the photoanode to cool down to room temperature.
- Preparation of the Dye Staining Solution:
 - Prepare a 0.3 mM to 0.5 mM solution of **D149 dye** in a suitable solvent (e.g., a 1:1 volume ratio of acetonitrile and tert-butanol).
 - Prepare a separate solution of CDCA in the same solvent.
 - Add the CDCA solution to the **D149 dye** solution to achieve the desired final concentration (e.g., a 10:1 molar ratio of CDCA to D149). Mix thoroughly.

- Dye Sensitization:
 - Immerse the prepared TiO₂ photoanode into the D149/CDCA staining solution.
 - Keep the photoanode in the solution for a specific duration (e.g., 2 to 12 hours) in a dark environment to allow for dye adsorption. The optimal time should be determined experimentally.
 - After sensitization, remove the photoanode from the solution and rinse it with the pure solvent to remove any non-adsorbed dye molecules.
 - Dry the sensitized photoanode.
- Assembly of the DSSC:
 - Prepare a counter electrode, typically by depositing a thin layer of a catalyst like platinum on another FTO glass substrate.
 - Place a thin thermoplastic sealant (e.g., Surlyn®) around the active area of the dye-sensitized photoanode.
 - Place the counter electrode on top of the photoanode, with the conductive sides facing each other.
 - Heat the assembly to melt the sealant and bond the two electrodes together, leaving a small gap for electrolyte injection.
- Electrolyte Injection and Sealing:
 - Introduce a liquid electrolyte (commonly containing an iodide/triiodide redox couple) into the cell through the pre-made holes in the counter electrode via vacuum backfilling.
 - Seal the injection holes with a sealant and a small cover glass to prevent electrolyte leakage.

Mandatory Visualizations

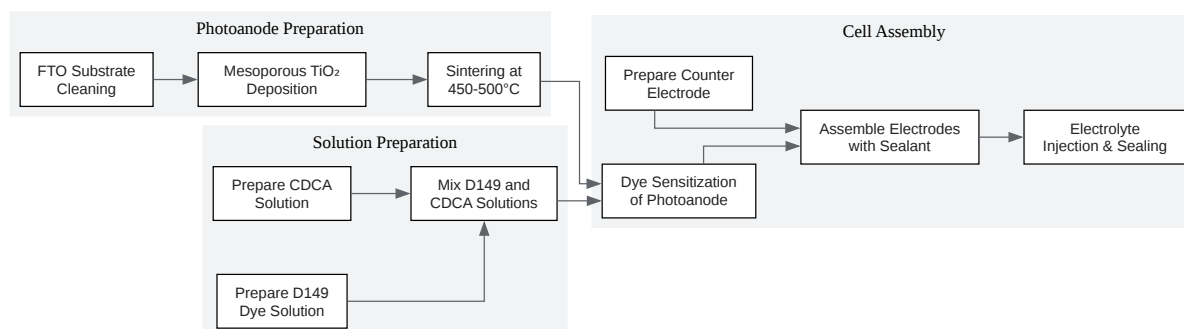

[Click to download full resolution via product page](#)

Caption: Experimental workflow for the fabrication of a D149-sensitized solar cell with CDCA.

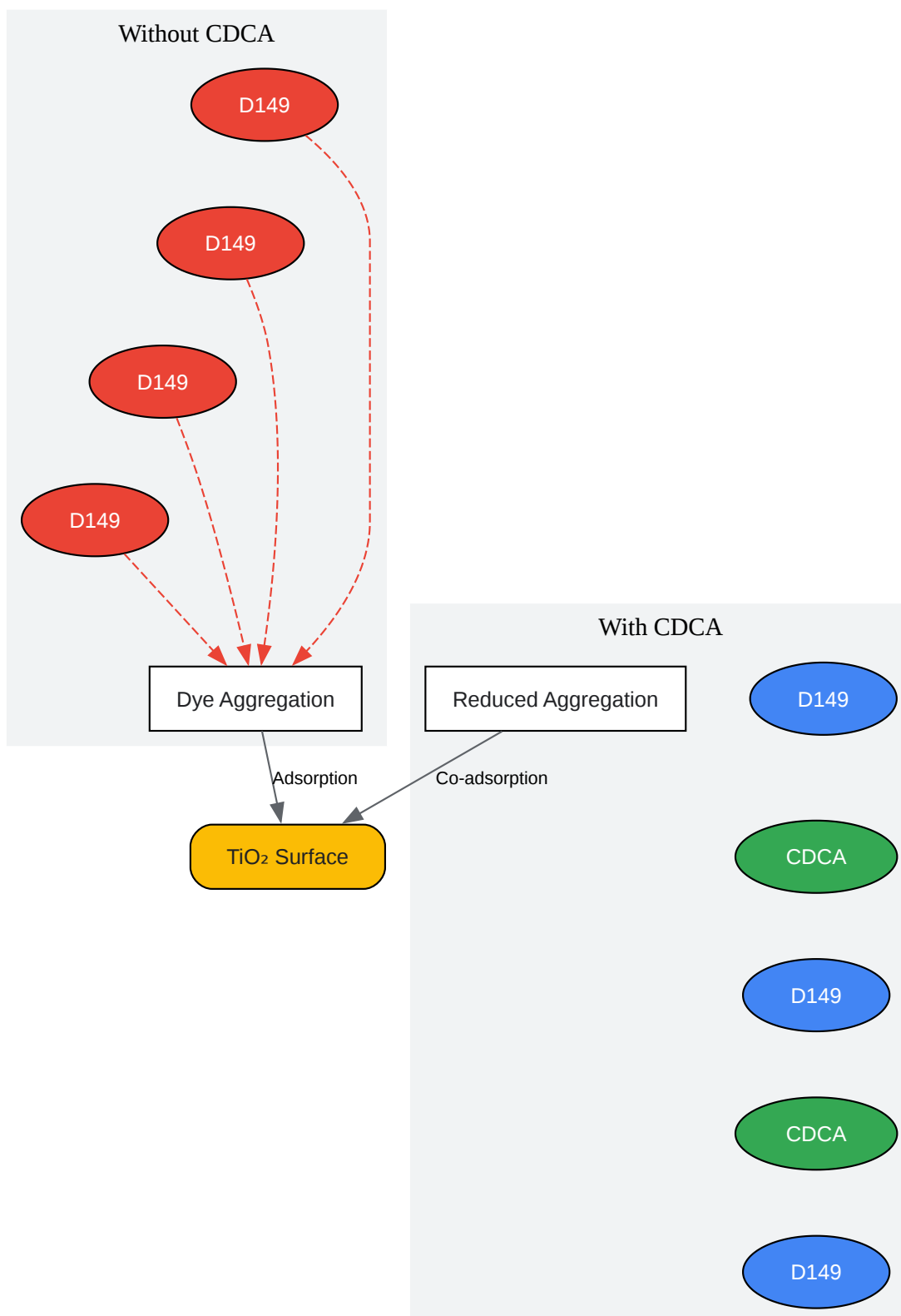

[Click to download full resolution via product page](#)

Caption: Mechanism of CDCA in preventing **D149 dye** aggregation on the TiO_2 surface.

Need Custom Synthesis?

BenchChem offers custom synthesis for rare earth carbides and specific isotopic labeling.

Email: info@benchchem.com or [Request Quote Online](#).

References

- [1. Isomerization and Aggregation of the Solar Cell Dye D149 - PMC \[pmc.ncbi.nlm.nih.gov\]](#)
- [2. researchgate.net \[researchgate.net\]](#)
- [3. benchchem.com \[benchchem.com\]](#)
- [4. solaronix.com \[solaronix.com\]](#)
- [5. tj.kyushu-u.ac.jp \[tj.kyushu-u.ac.jp\]](#)
- [6. researchgate.net \[researchgate.net\]](#)
- [7. researchgate.net \[researchgate.net\]](#)
- [8. pubs.acs.org \[pubs.acs.org\]](#)
- [9. researchgate.net \[researchgate.net\]](#)
- To cite this document: BenchChem. [Technical Support Center: Optimizing D149 Dye Performance with Chenodeoxycholic acid (CDCA)]. BenchChem, [2026]. [Online PDF]. Available at: [<https://www.benchchem.com/product/b1141169/docs#technical-support-center-optimizing-d149-dye-performance-with-chenodeoxycholic-acid-cdca>]

Disclaimer & Data Validity:

The information provided in this document is for Research Use Only (RUO) and is strictly not intended for diagnostic or therapeutic procedures. While BenchChem strives to provide accurate protocols, we make no warranties, express or implied, regarding the fitness of this product for every specific experimental setup.

Technical Support: The protocols provided are for reference purposes. Unsure if this reagent suits your experiment?

Need Industrial/Bulk Grade? [Request Custom Synthesis Quote](#)

BenchChem

Our mission is to be the trusted global source of essential and advanced chemicals, empowering scientists and researchers to drive progress in science and industry.

Contact

Address: 3281 E Guasti Rd

Ontario, CA 91761, United States

Phone: (601) 213-4426

Email: info@benchchem.com

[Contact our Ph.D. Support Team for a compatibility check](#)