

Technical Safety & Handling Guide: Zirconium Carboxyethyl Acrylate

Author: BenchChem Technical Support Team. **Date:** May 2026

Compound of Interest

Compound Name: Zirconium carboxyethyl acrylate

CAS No.: 123633-53-4

Cat. No.: B1141682

[Get Quote](#)

CAS: 123633-53-4 | Formula: $C_{24}H_{28}O_{16}Zr$ [1]

Part 1: Executive Technical Summary

Zirconium carboxyethyl acrylate (often abbreviated as Zr-CEA or a specific commercial code like CXZR050) is a heterometallic-organic hybrid monomer. It is primarily utilized by researchers in biomaterials, photonics, and dental composites to introduce high refractive index (RI) domains into polymer matrices without sacrificing transparency.

For drug development and biomedical engineers, this compound represents a critical "bridge" molecule—linking the inorganic durability of zirconium (radiopacity, hardness) with the organic reactivity of acrylates (photopolymerization). However, its dual nature presents a complex safety profile combining the sensitization risks of acrylates with the heavy metal toxicity profile of zirconium, often exacerbated by flammable carrier solvents like n-propanol.

Key Hazard Vector: The compound is thermodynamically unstable in the presence of moisture (hydrolysis) and kinetically unstable in the absence of oxygen (uncontrolled polymerization).

Part 2: Physicochemical Characterization & Stability

Understanding the physical state is a prerequisite for safety.

Property	Data / Characteristic	Implication for Safety
Physical State	Viscous liquid (often 60-95% solution in n-propanol)	High viscosity complicates spill cleanup; solvent vapors pose flammability risks.
Hydrolytic Stability	Low (Moisture Sensitive)	Exposure to humidity releases free acrylic acid and zirconium oxides/hydroxides.
Polymerization	High (Light/Heat Sensitive)	Contains inhibitors (MEHQ) that require dissolved oxygen. Do not sparge with pure Nitrogen.
Refractive Index	~1.45 - 1.55 (tunable)	N/A (Performance metric).
Solubility	Soluble in alcohols, acrylates. Insoluble in water (hydrolyzes). [2]	Use organic solvents (IPA, acetone) for decontamination, not water initially.

Part 3: Toxicological Profile & Mechanism

Causality-driven analysis of health risks.

1. The Acrylate Moiety (Sensitization)

The carboxyethyl acrylate ligands are potent skin sensitizers. Unlike simple acids, the acrylate double bond (

) acts as a Michael acceptor, capable of alkylating skin proteins (hapteneization).

- Acute Effect: Irritant contact dermatitis (redness, blistering).
- Chronic Effect: Allergic contact dermatitis (ACD). Once sensitized, researchers may experience anaphylactic-type reactions to any acrylate (cross-sensitization).

2. The Zirconium Core (Granuloma & Irritation)

While zirconium is generally considered biocompatible (hence its use in implants), inhalation of zirconium compounds in aerosol form is linked to zirconium granulomas—immune system clusters in the lungs or skin.

- Target Organs: Respiratory system (inhalation of mists), Skin (granulomatous lesions).

3. Solvent Vector (Systemic Toxicity)

Commercial preparations are frequently supplied in n-propanol.

- Risk: CNS depression (dizziness, drowsiness) and severe eye damage (Category 1).

GHS Hazard Classification (Consolidated)

- Flammable Liquid Cat. 2 (H225)[3]
- Skin Irritation Cat.[3][4] 2 (H315)[3][4]
- Eye Damage Cat. 1 (H318)
- Skin Sensitization Cat.[3][4] 1 (H317)[3][4]
- STOT-SE Cat.[3] 3 (H335 Respiratory / H336 CNS)[3]

Part 4: Visualization of Hazard Pathways

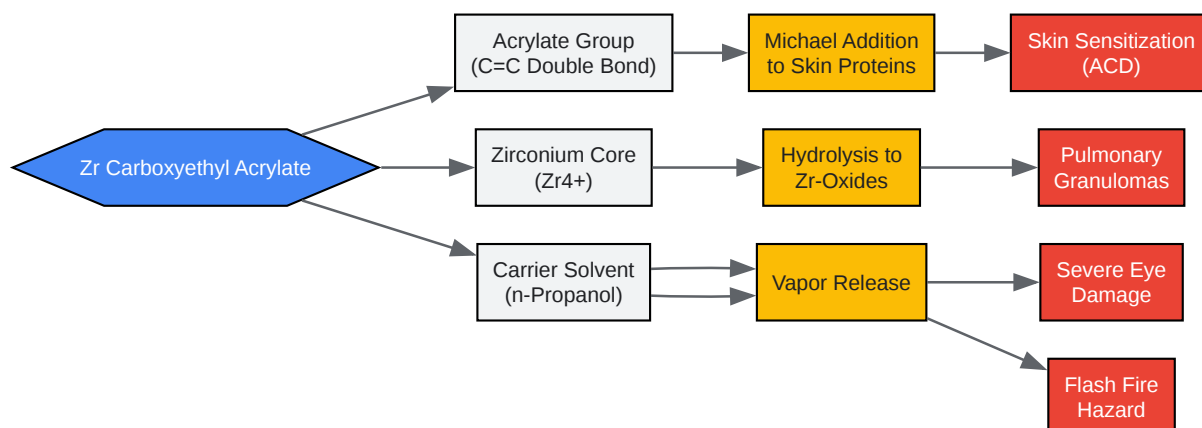

[Click to download full resolution via product page](#)

Figure 1: Mechanistic decomposition of hazards associated with **Zirconium Carboxyethyl Acrylate**.

Part 5: Operational Safety Protocols

Self-validating workflows for researchers.

Protocol A: Personal Protective Equipment (PPE) Matrix

Rationale: Latex gloves are permeable to acrylates. Standard nitrile is often insufficient for prolonged immersion in n-propanol.

- Respiratory: If handling outside a fume hood, use a half-mask respirator with Organic Vapor/Acid Gas (OV/AG) cartridges (Yellow/Olive label). The "Acid Gas" component protects against acrylic acid released via hydrolysis.
- Dermal (Hands): Double-gloving strategy.
 - Inner Layer: 4 mil Nitrile (dexterity).
 - Outer Layer: Silver Shield/4H (laminated PE/EVOH) or thick Nitrile (>8 mil) if handling neat solution. Discard outer glove immediately upon splash.
- Ocular: Chemical splash goggles (indirect vented). Face shield required if pouring volumes >100mL.

Protocol B: Storage & Stability Management

Critical Failure Mode: Uncontrolled Polymerization.

- Oxygen is Vital: The inhibitor (MEHQ) requires dissolved oxygen to function.
 - Action: Store in the original container with headspace. Do NOT purge with pure nitrogen or argon. Use "dry air" if moisture exclusion is needed.
- Temperature: Store at 5°C – 25°C. Refrigeration is recommended but ensure the container is sealed to prevent moisture condensation (hydrolysis risk).

- Light: Store in amber glass or opaque HDPE to prevent UV-initiated polymerization.

Protocol C: Emergency Spill Response

Logic: Prevent polymerization during cleanup, which generates heat and toxic fumes.

- Evacuate & Ventilate: Remove ignition sources (Flash point ~15°C for solution).
- Assess Volume:
 - < 50 mL: Absorb with paper towels.
 - > 50 mL: Use inert absorbent (Vermiculite or Clay).[5] Do NOT use sawdust (combustible + oxidant risk).
- Deactivation (The "Cure" Method):
 - Instead of trying to wipe up a sticky resin, researchers often cure the residue in situ if safe (UV light) to turn it into a solid plastic, then scrape it up. Warning: This generates heat.[6]
 - Preferred Method: Absorb, then wipe surface with Isopropyl Alcohol (IPA). Wash final residue with soap and water.[4][5][6][7][8]

Part 6: Biomedical & Research Context

For scientists in drug delivery and device fabrication:

- Dental Applications: Used as a coupling agent in dental composites to bond Zirconia fillers to resin matrices. Ensure complete polymerization; unreacted monomer is cytotoxic to pulp tissue.
- MOF Synthesis: When used as a precursor for Metal-Organic Frameworks (MOFs), the hydrolysis step is controlled to create Zr-O clusters. Safety during this step is critical as acid byproducts are generated rapidly.
- High-RI Coatings: Used in ophthalmic device coatings. The high refractive index allows for thinner lenses.

Part 7: Emergency Decision Logic

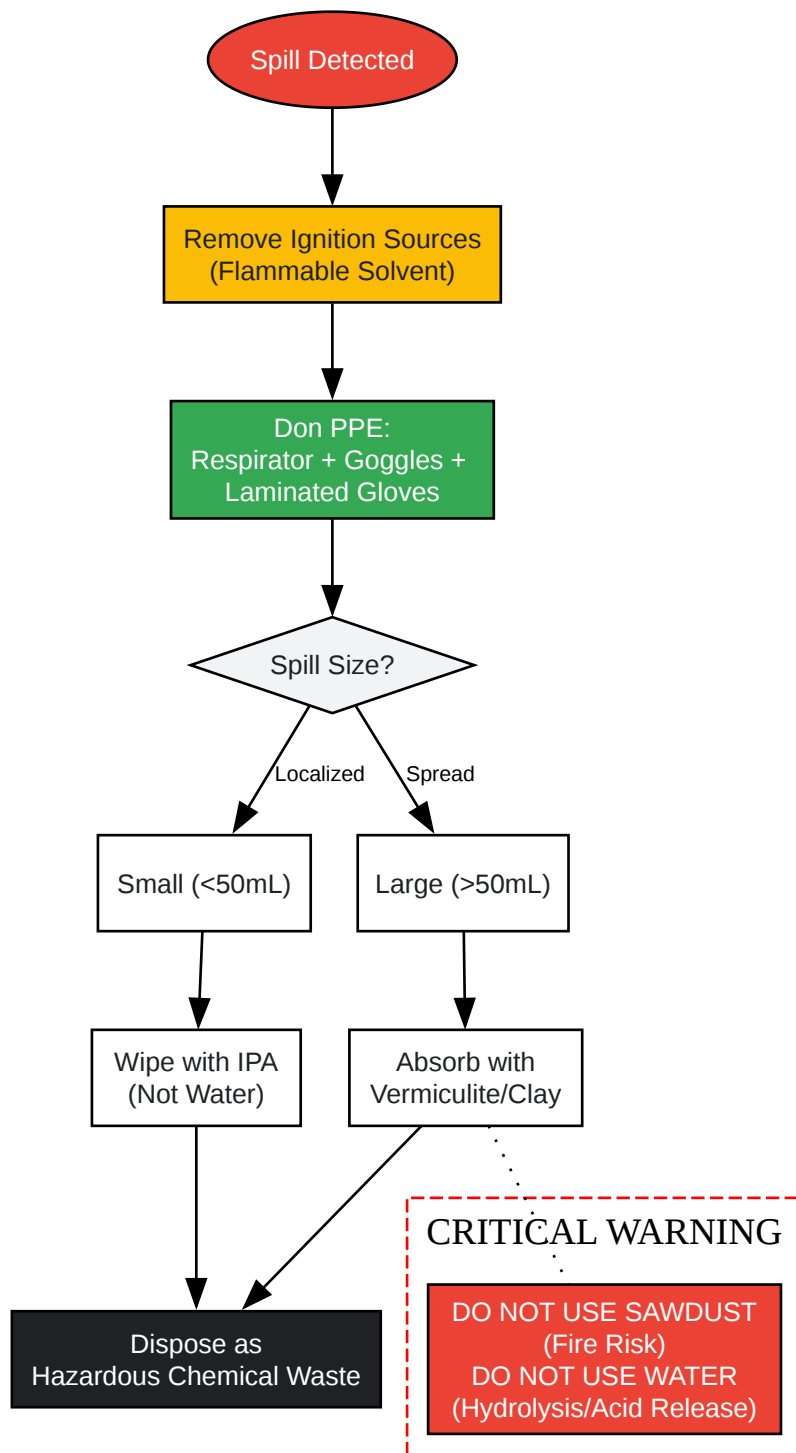

[Click to download full resolution via product page](#)

Figure 2: Decision tree for spill response, prioritizing solvent flammability and chemical reactivity.

References

- Santa Cruz Biotechnology. **Zirconium carboxyethyl acrylate** (CAS 123633-53-4) Product Data & Safety. Retrieved from
- Gelest, Inc. **Zirconium Carboxyethyl Acrylate** Safety Data Sheet (SDS) - Code CXZR050. Retrieved from
- Sigma-Aldrich. **Zirconium carboxyethyl acrylate** solution - Product Specification & SDS. Retrieved from
- ResearchGate. Application of Zirconium MOFs in Drug Delivery and Biomedicine. (Contextual usage in drug development). Retrieved from

Need Custom Synthesis?

BenchChem offers custom synthesis for rare earth carbides and specific isotopic labeling.

Email: info@benchchem.com or [Request Quote Online](#).

Sources

- [1. Zirconium carboxyethyl acrylate | CAS 123633-53-4 | SCBT - Santa Cruz Biotechnology \[scbt.com\]](#)
- [2. americanelements.com \[americanelements.com\]](#)
- [3. tcichemicals.com \[tcichemicals.com\]](#)
- [4. api.henkeldx.com \[api.henkeldx.com\]](#)
- [5. gelest.com \[gelest.com\]](#)
- [6. gelest.com \[gelest.com\]](#)
- [7. gelest.com \[gelest.com\]](#)
- [8. solutions.covestro.com \[solutions.covestro.com\]](#)
- To cite this document: BenchChem. [Technical Safety & Handling Guide: Zirconium Carboxyethyl Acrylate]. BenchChem, [2026]. [Online PDF]. Available at: [\[https://www.benchchem.com/product/b1141682/docs#technical-safety-handling-guide-zirconium-carboxyethyl-acrylate\]](https://www.benchchem.com/product/b1141682/docs#technical-safety-handling-guide-zirconium-carboxyethyl-acrylate)

Disclaimer & Data Validity:

The information provided in this document is for Research Use Only (RUO) and is strictly not intended for diagnostic or therapeutic procedures. While BenchChem strives to provide accurate protocols, we make no warranties, express or implied, regarding the fitness of this product for every specific experimental setup.

Technical Support: The protocols provided are for reference purposes. Unsure if this reagent suits your experiment?

Need Industrial/Bulk Grade? [Request Custom Synthesis Quote](#)

BenchChem

Our mission is to be the trusted global source of essential and advanced chemicals, empowering scientists and researchers to drive progress in science and industry.

Contact

Address: 3281 E Guasti Rd
Ontario, CA 91761, United States
Phone: (601) 213-4426
Email: info@benchchem.com

[Contact our Ph.D. Support Team for a compatibility check](#)