

Application Notes and Protocols for Sensitizing TiO₂ with D149 Dye

Author: BenchChem Technical Support Team. **Date:** April 2026

Compound of Interest

Compound Name: D149 Dye

Cat. No.: B1141169

[Get Quote](#)

This document provides a comprehensive, step-by-step guide for researchers, scientists, and professionals in drug development on the sensitization of titanium dioxide (TiO₂) nanocrystalline films with the organic indoline dye, D149. The following protocols are designed to facilitate the reproducible fabrication of dye-sensitized photoanodes for applications such as dye-sensitized solar cells (DSSCs).

Introduction

The sensitization of wide-bandgap semiconductors like TiO₂ with organic dyes is a critical process in the development of efficient dye-sensitized solar cells. The indoline dye D149 is a metal-free organic sensitizer known for its high molar extinction coefficient, which allows for the use of thinner TiO₂ layers compared to ruthenium-based dyes.^[1] Proper sensitization is paramount to achieving high power conversion efficiencies by ensuring efficient light harvesting and electron injection from the dye's excited state to the conduction band of the TiO₂. This guide outlines the materials, equipment, and detailed procedures for the successful sensitization of TiO₂ films with **D149 dye**.

Materials and Equipment

Reagents

- Titanium dioxide (TiO₂) paste (e.g., binder-free paste like PECC-K01)
- **D149 dye** (5-[(E)-2-(1,1,6,6-tetramethyl-1,2,3,5,6,7-hexahydro-4H-pyrano[3,2-c]pyridin-4-ylidene)ethylidene]-3-ethyl-2-thioxo-4-thiazolidinone)
- Acetonitrile (anhydrous)
- tert-Butanol (anhydrous)
- Ethanol (anhydrous)
- Indium Tin Oxide (ITO) or Fluorine-doped Tin Oxide (FTO) coated glass substrates
- Deionized water

Equipment

- Doctor-blade coater or screen printer
- Hot plate
- Furnace capable of reaching 500°C
- Shaking incubator or orbital shaker
- UV-Vis spectrophotometer
- Glove box or dry environment for cell assembly
- Ultrasonic bath
- Standard laboratory glassware and consumables (pipettes, beakers, petri dishes)

Experimental Protocols

Preparation of TiO₂ Photoanodes

A critical prerequisite for effective dye sensitization is the preparation of a mesoporous TiO₂ film with a high surface area.

Protocol 1: Fabrication of TiO₂ Films

- **Substrate Cleaning:** Thoroughly clean the conductive glass substrates (ITO or FTO) by sequential ultrasonication in deionized water, acetone, and finally ethanol, for 15 minutes each. Dry the substrates with a stream of nitrogen or clean air.
- **TiO₂ Paste Deposition:** Apply the TiO₂ paste onto the conductive side of the substrate using a doctor-blade technique to ensure a uniform thickness. The thickness of the film can be controlled by the height of the doctor blade or by applying layers of adhesive tape on the sides of the substrate as spacers.[2][3]
- **Drying and Sintering:**
 - For low-temperature methods on plastic substrates, dry the coated film at a temperature such as 130°C for 5 minutes.[1]
 - For high-temperature sintering on glass substrates, pre-heat the film on a hot plate at approximately 150°C for 10 minutes to evaporate organic binders.[2] Subsequently, sinter the films in a furnace at 450-500°C for at least one hour.[4] This high-temperature treatment removes organic binders and ensures good electrical contact between the TiO₂ nanoparticles.
- **Cooling:** Allow the sintered TiO₂ films to cool down to room temperature before the dye sensitization step.

Preparation of D149 Dye Solution

Protocol 2: Dye Solution Preparation

- Prepare a 0.4 mM solution of **D149 dye** in a 1:1 (v/v) mixture of acetonitrile and tert-butanol. [1]
- Ensure the solvents are of high purity and anhydrous to prevent any adverse reactions.
- The dye solution should be prepared in a dark environment or in a container protected from light to avoid photodegradation.

Sensitization of TiO₂ Films

Protocol 3: Dye Adsorption Process

- Immediately after cooling, immerse the TiO₂-coated substrates into the prepared **D149 dye** solution. The immersion should be carried out in a sealed, dark container to prevent solvent evaporation and light exposure.
- Place the container in a shaking incubator or on an orbital shaker with slow shaking at 40°C.
[1]
- The optimal immersion time for achieving the highest conversion efficiency has been found to be 1.5 hours.[1] Longer immersion times may lead to the exfoliation of the TiO₂ film.[1]
- After the sensitization period, remove the photoanodes from the dye solution.
- Rinse the sensitized photoanodes with fresh ethanol to remove any non-adsorbed dye molecules from the surface.[2]
- Dry the sensitized photoanodes in a clean, dark environment before assembling them into a solar cell.

Data Presentation

The following tables summarize key quantitative data related to the sensitization of TiO₂ with **D149 dye** and the performance of the resulting dye-sensitized solar cells.

| Parameter | Value | Reference |
|---------------------------------|---------------------------------------|-----------|
| Dye | D149 (Indoline) | [1] |
| Dye Concentration | 0.4 mM | [1] |
| Solvent | Acetonitrile / tert-Butanol (1:1 v/v) | [1] |
| Sensitization Temperature | 40°C | [1] |
| Sensitization Time | 1.5 hours | [1] |
| TiO ₂ Film Thickness | ~10 μm | [5] |
| TiO ₂ Particle Size | 20-34 nm | [6] |

 Table 1: Optimal Conditions for **D149 Dye** Sensitization of TiO₂ Films.

| Performance Metric | Value | Conditions/Notes | Reference |
|--|--|---|-----------|
| Power Conversion Efficiency (PCE) | 3.7% | On plastic-based DSC with TiO ₂ buffer layer | [1][7] |
| 5.8 ± 0.2% | On amorphous-free P25 TiO ₂ | [6] | |
| 3.9 ± 0.4% | On as-received P25 TiO ₂ | [6] | |
| Short-Circuit Current Density (J _{sc}) | 7.8 mA cm ⁻² | With 15 g m ⁻² TiO ₂ loading | [1] |
| Open-Circuit Voltage (V _{oc}) | Increased by 30 mV | With TiO ₂ buffer layer | [1] |
| Fill Factor (FF) | 0.66 | With TiO ₂ buffer layer | [1] |

Table 2: Photovoltaic Performance of D149-Sensitized Solar Cells.

Diagrams

Experimental Workflow

The following diagram illustrates the step-by-step workflow for the preparation of D149-sensitized TiO₂ photoanodes.

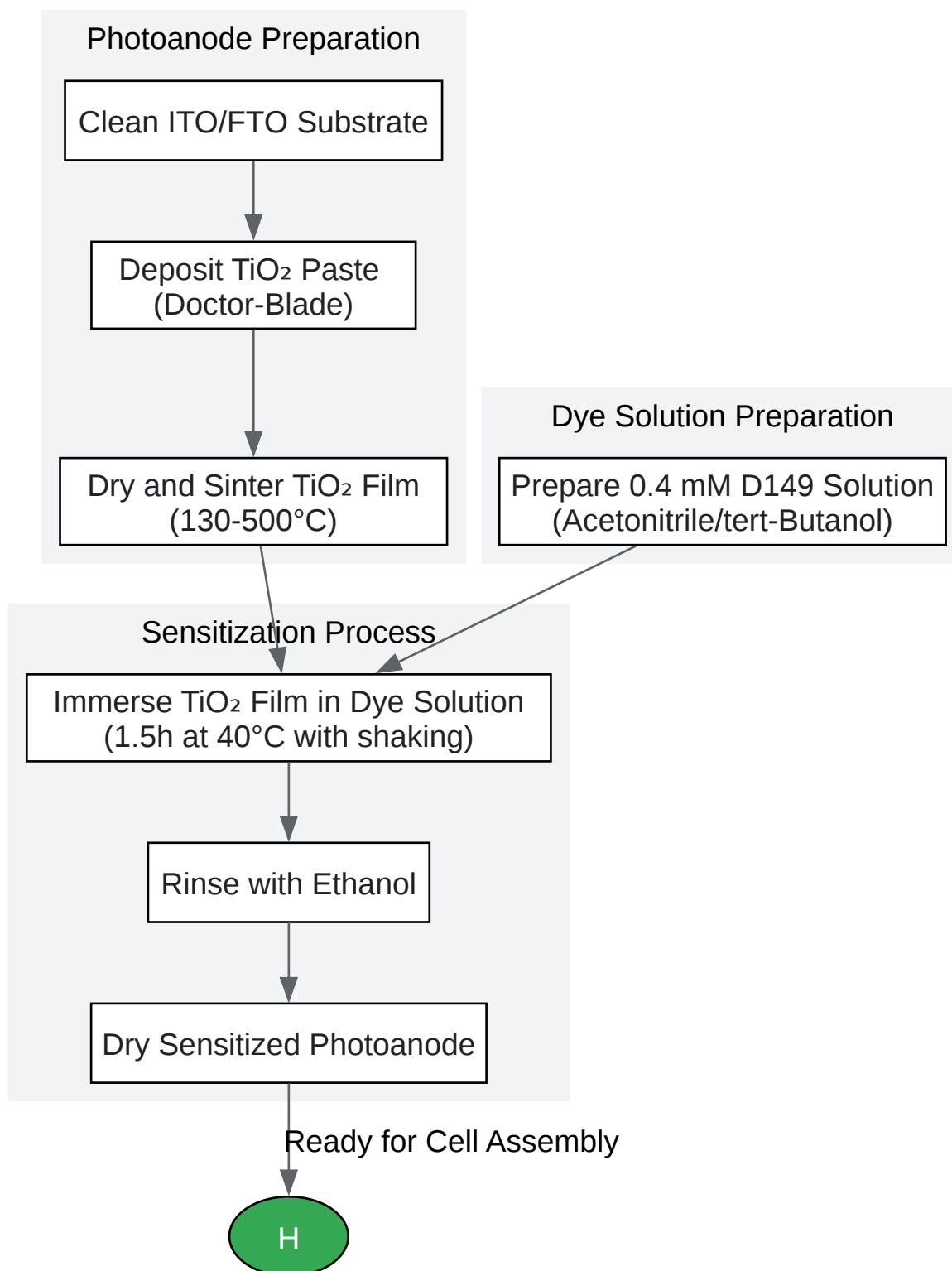

[Click to download full resolution via product page](#)

Caption: Workflow for TiO₂ Photoanode Sensitization with **D149 Dye**.

Dye Sensitization and Electron Transfer Mechanism

The diagram below illustrates the fundamental mechanism of dye sensitization and electron transfer in a D149-sensitized solar cell.

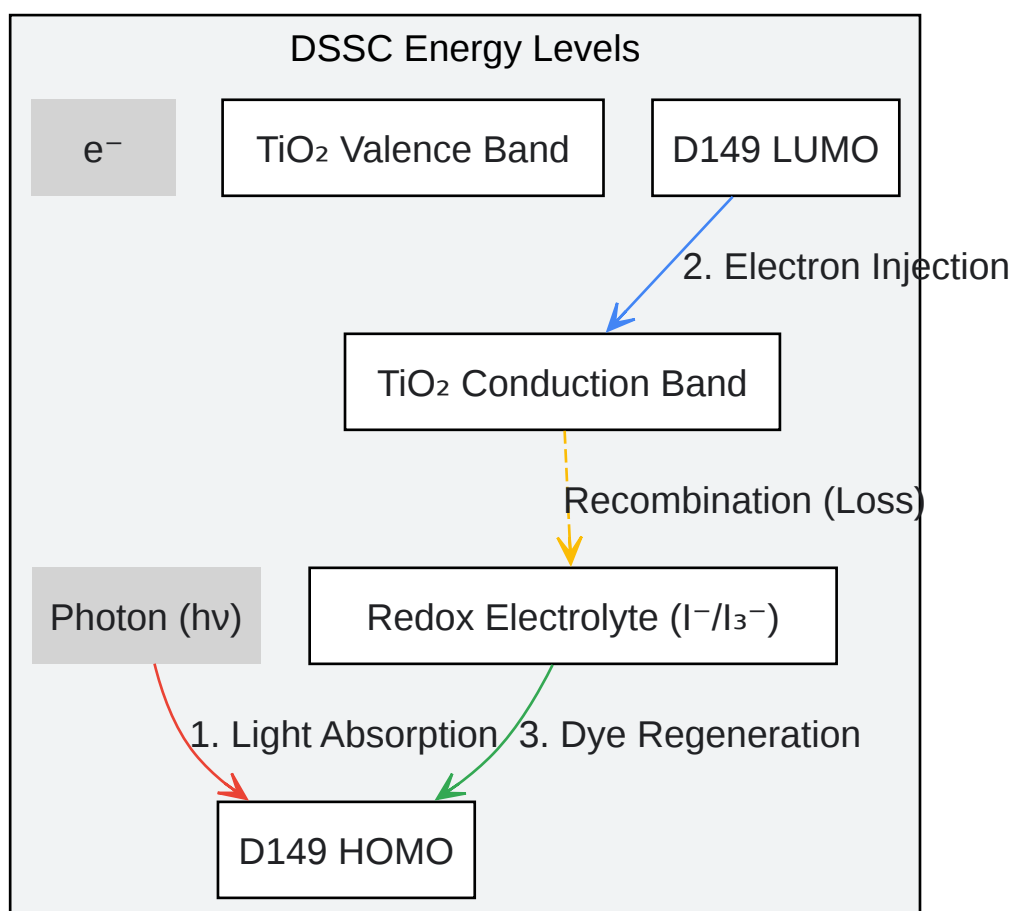

[Click to download full resolution via product page](#)

Caption: Energy diagram of the **D149 dye** sensitization process in a DSSC.

Need Custom Synthesis?

BenchChem offers custom synthesis for rare earth carbides and specific isotopic labeling.

Email: info@benchchem.com or [Request Quote Online](#).

References

- [1. scispace.com \[scispace.com\]](#)
- [2. www3.nd.edu \[www3.nd.edu\]](#)
- [3. Fabrication of Dye Sensitized Solar Cell Based on Titanium Dioxide \(TiO₂\) \[scirp.org\]](#)
- [4. materiability.com \[materiability.com\]](#)
- [5. sensors.myu-group.co.jp \[sensors.myu-group.co.jp\]](#)
- [6. mdpi.com \[mdpi.com\]](#)
- [7. discovery.researcher.life \[discovery.researcher.life\]](#)
- To cite this document: BenchChem. [Application Notes and Protocols for Sensitizing TiO₂ with D149 Dye]. BenchChem, [2026]. [Online PDF]. Available at: [\[https://www.benchchem.com/product/b1141169/docs#application-notes-and-protocols-for-sensitizing-tio-with-d149-dye\]](https://www.benchchem.com/product/b1141169/docs#application-notes-and-protocols-for-sensitizing-tio-with-d149-dye)

Disclaimer & Data Validity:

The information provided in this document is for Research Use Only (RUO) and is strictly not intended for diagnostic or therapeutic procedures. While BenchChem strives to provide accurate protocols, we make no warranties, express or implied, regarding the fitness of this product for every specific experimental setup.

Technical Support: The protocols provided are for reference purposes. Unsure if this reagent suits your experiment?

Need Industrial/Bulk Grade? [Request Custom Synthesis Quote](#)

BenchChem

Our mission is to be the trusted global source of essential and advanced chemicals, empowering scientists and researchers to drive progress in science and industry.

Contact

Address: 3281 E Guasti Rd
Ontario, CA 91761, United States
Phone: (601) 213-4426
Email: info@benchchem.com

Contact our Ph.D. Support Team for a compatibility check