

Pharmacological Properties of (3R)-Hydroxyquinidine: A Technical Whitepaper

Author: BenchChem Technical Support Team. **Date:** December 2025

Compound of Interest

Compound Name: (3R)-Hydroxyquinidine

Cat. No.: B1140840

[Get Quote](#)

Disclaimer: The pharmacological properties of the (3R) stereoisomer of hydroxyquinidine are not extensively characterized in publicly available scientific literature. The majority of research focuses on the primary metabolite of quinidine, (3S)-Hydroxyquinidine, or refers to "3-hydroxyquinidine" without specifying the stereoisomer. This document provides a comprehensive overview of the known pharmacology of 3-hydroxyquinidine, with the understanding that much of the detailed data pertains to the (3S) isomer or an undefined mixture. For the purposes of this guide, "3-Hydroxyquinidine" will be used to refer to data where the specific stereoisomer was not defined in the source material.

Introduction

(3R)-Hydroxyquinidine is a stereoisomer of 3-hydroxyquinidine, a primary active metabolite of the Class Ia antiarrhythmic drug, quinidine. As a metabolite, its pharmacological actions may contribute to the overall therapeutic and toxic effects observed during quinidine therapy. Understanding the specific properties of each stereoisomer is crucial for a complete pharmacological profile and for the development of safer and more effective antiarrhythmic agents. This technical guide synthesizes the available information on the pharmacology of 3-hydroxyquinidine, with a focus on its mechanism of action, pharmacokinetics, and pharmacodynamics, while highlighting the significant knowledge gap concerning the specific (3R) isomer.

Mechanism of Action

The antiarrhythmic effects of 3-hydroxyquinidine, much like its parent compound quinidine, are primarily attributed to the blockade of cardiac ion channels. The primary mechanism involves the inhibition of both fast inward sodium channels and several potassium channels, leading to a prolongation of the cardiac action potential.

Ion Channel Activity

Sodium Channel Blockade: 3-Hydroxyquinidine exhibits a use-dependent blockade of the fast inward sodium current (I_{Na}), which is characteristic of Class I antiarrhythmic agents. This action reduces the maximum rate of depolarization of the cardiac action potential (V_{max}), thereby slowing conduction velocity in the atria, ventricles, and His-Purkinje system. Studies on guinea pig ventricular cells have shown that hydroxy-quinidine (stereoisomer not specified) produces a concentration-dependent depression of V_{max} , albeit to a lesser degree than quinidine itself^[1].

Potassium Channel Blockade: 3-Hydroxyquinidine also blocks several potassium currents, contributing to a prolonged repolarization phase of the action potential. This is reflected as a prolongation of the QT interval on an electrocardiogram (ECG). The primary potassium channels affected are the rapid (I_{Kr}) and slow (I_{Ks}) components of the delayed rectifier potassium current. Blockade of these channels increases the action potential duration (APD) and the effective refractory period (ERP) of cardiac tissues^[1].

Signaling Pathway

The following diagram illustrates the general mechanism of action of 3-hydroxyquinidine on cardiac myocytes, leading to its antiarrhythmic effects.

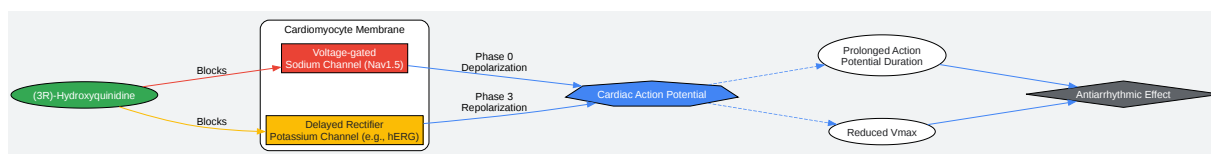

[Click to download full resolution via product page](#)

Mechanism of action of 3-Hydroxyquinidine on cardiac ion channels.

Quantitative Pharmacological Data

Quantitative data specifically for **(3R)-Hydroxyquinidine** is scarce. The following table summarizes available data for "3-hydroxyquinidine" and its (3S) isomer. Researchers should exercise caution when extrapolating these values to the (3R) isomer.

Parameter	Value	Species/System	Comments	Reference
Pharmacokinetics				
Oral Bioavailability (F)	Not explicitly determined for the metabolite alone.	Human	As a metabolite of quinidine.	[2]
Elimination Half-life (t _{1/2})	~12 hours	Human	For (3S)-Hydroxyquinidine	
Renal Clearance	1.54 ± 0.38 mL/min/kg (single dose) to 3.0 ± 1.1 mL/min/kg (steady state)	Human	For 3-hydroxyquinidine	[2][3]
Pharmacodynamics				
V _{max} Depression	Less potent than quinidine.	Guinea Pig Ventricular Cells	For hydroxy-3S-quinidine.	[1]
Action Potential Duration (APD) Prolongation	Potent effect, not altered by increasing pacing rate.	Guinea Pig Ventricular Cells	For hydroxy-3S-quinidine.	[1]
QTc Prolongation	Statistically significant correlation with serum concentration.	Human	For 3-hydroxyquinidine	[4]

Experimental Protocols

Detailed experimental protocols for the characterization of **(3R)-Hydroxyquinidine** are not readily available. However, based on studies of quinidine and its other metabolites, the following methodologies are relevant.

Synthesis of (3S)-Hydroxyquinidine

A reported method for the synthesis of (3S)-Hydroxyquinidine involves the microbial oxidation of quinidine[5].

Protocol:

- **Microorganism Culture:** Cultivate a suitable microorganism known for hydroxylation reactions (e.g., certain fungal or bacterial strains) in an appropriate growth medium.
- **Substrate Addition:** Introduce quinidine to the microbial culture.
- **Incubation:** Incubate the culture under controlled conditions (temperature, pH, aeration) to allow for microbial metabolism of quinidine.
- **Extraction:** After a sufficient incubation period, extract the culture broth with an organic solvent (e.g., ethyl acetate).
- **Purification:** Purify the extracted compounds using chromatographic techniques, such as column chromatography or high-performance liquid chromatography (HPLC), to isolate (3S)-Hydroxyquinidine.
- **Characterization:** Confirm the structure and purity of the synthesized compound using analytical methods like NMR, mass spectrometry, and IR spectroscopy.

In Vitro Electrophysiology (Patch-Clamp)

To assess the effects of **(3R)-Hydroxyquinidine** on cardiac ion channels, the whole-cell patch-clamp technique is employed.

Protocol:

- **Cell Preparation:** Isolate single ventricular myocytes from an appropriate animal model (e.g., guinea pig, rabbit) or use a stable cell line expressing the human ion channel of interest

(e.g., HEK293 cells expressing hNav1.5 or hERG).

- **Pipette Preparation:** Fabricate glass micropipettes and fill them with an internal solution mimicking the intracellular ionic composition.
- **Seal Formation:** Achieve a high-resistance "giga-seal" between the micropipette tip and the cell membrane.
- **Whole-Cell Configuration:** Rupture the cell membrane patch under the pipette tip to gain electrical access to the cell's interior.
- **Voltage Clamp:** Clamp the cell membrane potential at a holding potential and apply specific voltage protocols to elicit and record ionic currents.
- **Drug Application:** Perfuse the cell with an external solution containing known concentrations of **(3R)-Hydroxyquinidine**.
- **Data Acquisition and Analysis:** Record the changes in ionic currents in the presence of the compound and analyze the data to determine parameters such as IC50 values and the kinetics of channel blockade.

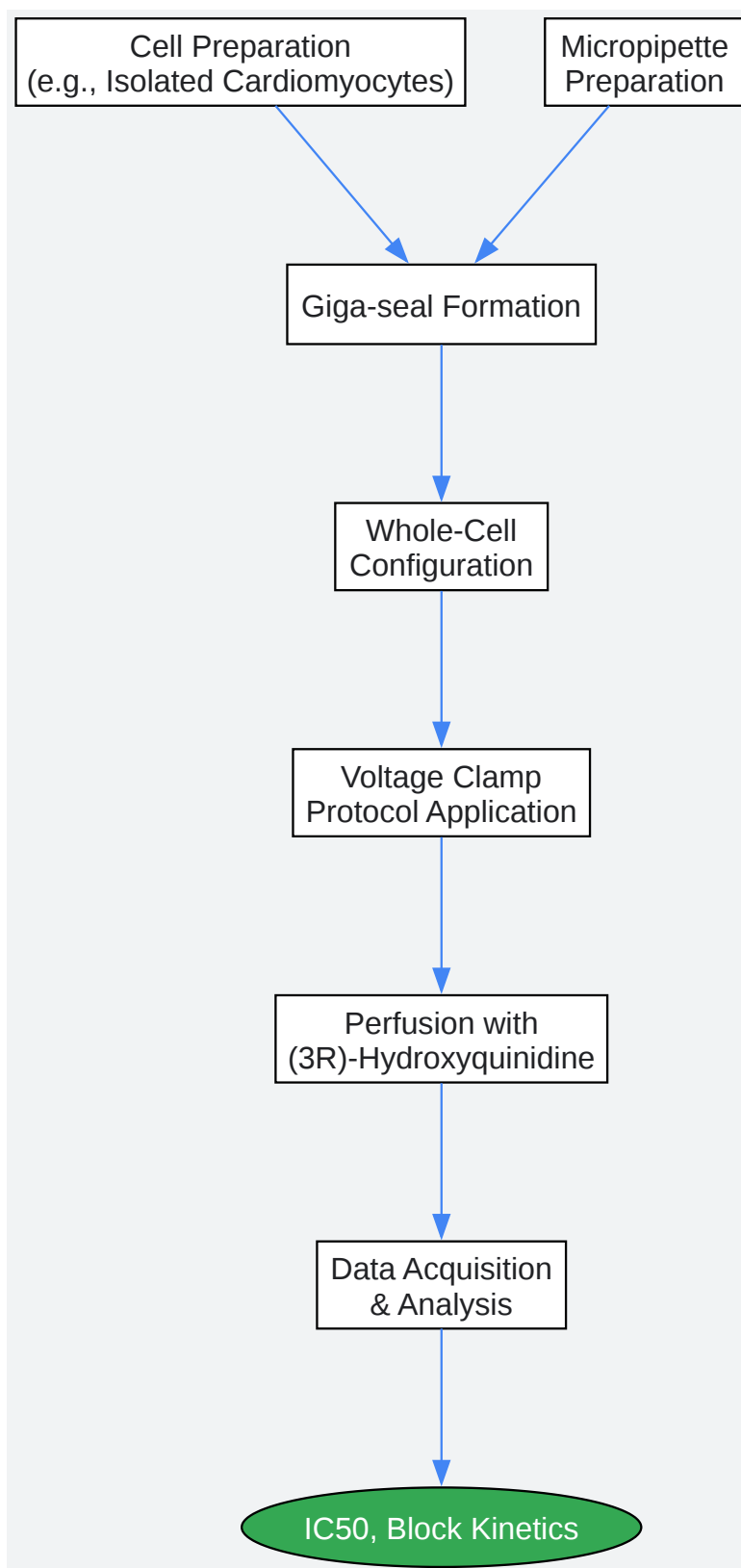

[Click to download full resolution via product page](#)

Workflow for in vitro electrophysiological assessment.

High-Performance Liquid Chromatography (HPLC) for Pharmacokinetic Analysis

To determine the concentration of **(3R)-Hydroxyquinidine** in biological samples, a validated HPLC method is required.

Protocol:

- Sample Preparation:
 - For plasma or serum: Perform protein precipitation by adding a solvent like acetonitrile or methanol. Centrifuge to pellet the precipitated proteins.
 - Extract the supernatant containing the analyte using a suitable organic solvent.
 - Evaporate the organic solvent and reconstitute the residue in the mobile phase.
- Chromatographic Conditions:
 - Column: Use a reverse-phase C18 column.
 - Mobile Phase: A mixture of an aqueous buffer (e.g., phosphate buffer) and an organic modifier (e.g., acetonitrile or methanol), run in either isocratic or gradient mode.
 - Flow Rate: Typically 1 mL/min.
 - Detection: Use a fluorescence detector for high sensitivity and selectivity, with appropriate excitation and emission wavelengths for hydroxyquinidine.
- Quantification:
 - Prepare a calibration curve using standards of known **(3R)-Hydroxyquinidine** concentrations.
 - Inject the prepared samples and standards into the HPLC system.
 - Determine the concentration of **(3R)-Hydroxyquinidine** in the samples by comparing their peak areas to the calibration curve.

Conclusion and Future Directions

The pharmacological properties of 3-hydroxyquinidine indicate that it is an active metabolite of quinidine with significant Class I antiarrhythmic effects. However, the existing literature is severely lacking in data that specifically characterizes the (3R) stereoisomer. To fully understand the contribution of each stereoisomer to the overall pharmacological and toxicological profile of quinidine, further research is imperative.

Future studies should focus on:

- The stereoselective synthesis of **(3R)-Hydroxyquinidine** to obtain a pure standard for pharmacological testing.
- Direct comparative studies of the in vitro electrophysiological effects of (3R)- and (3S)-Hydroxyquinidine on key cardiac ion channels.
- Determination of specific IC₅₀ and K_i values for **(3R)-Hydroxyquinidine** at relevant sodium and potassium channels.
- In vivo studies to characterize the specific pharmacokinetic and pharmacodynamic profiles of the (3R) isomer.

A thorough investigation into the distinct properties of **(3R)-Hydroxyquinidine** will provide valuable insights for drug development professionals and researchers in the field of cardiac electrophysiology and antiarrhythmic therapy.

Need Custom Synthesis?

BenchChem offers custom synthesis for rare earth carbides and specific isotopic labeling.

Email: info@benchchem.com or [Request Quote Online](#).

References

- 1. Comparative electrophysiologic effects of metabolites of quinidine and hydroquinidine - PubMed [pubmed.ncbi.nlm.nih.gov]

- 2. The pharmacokinetics and pharmacodynamics of quinidine and 3-hydroxyquinidine - PMC [pmc.ncbi.nlm.nih.gov]
- 3. The pharmacokinetics and pharmacodynamics of quinidine and 3-hydroxyquinidine - PubMed [pubmed.ncbi.nlm.nih.gov]
- 4. Pharmacodynamics of 3-hydroxyquinidine alone and in combination with quinidine in healthy persons - PubMed [pubmed.ncbi.nlm.nih.gov]
- 5. (3S)-3-hydroxyquinidine, the major biotransformation product of quinidine. Synthesis and conformational studies. X-Ray molecular structure of (3S)-3-hydroxyquinidine methanesuiphonate - Journal of the Chemical Society, Perkin Transactions 1 (RSC Publishing) [pubs.rsc.org]
- To cite this document: BenchChem. [Pharmacological Properties of (3R)-Hydroxyquinidine: A Technical Whitepaper]. BenchChem, [2025]. [Online PDF]. Available at: [https://www.benchchem.com/product/b1140840#pharmacological-properties-of-3r-hydroxyquinidine]

Disclaimer & Data Validity:

The information provided in this document is for Research Use Only (RUO) and is strictly not intended for diagnostic or therapeutic procedures. While BenchChem strives to provide accurate protocols, we make no warranties, express or implied, regarding the fitness of this product for every specific experimental setup.

Technical Support: The protocols provided are for reference purposes. Unsure if this reagent suits your experiment? [[Contact our Ph.D. Support Team for a compatibility check](#)]

Need Industrial/Bulk Grade? [Request Custom Synthesis Quote](#)

BenchChem

Our mission is to be the trusted global source of essential and advanced chemicals, empowering scientists and researchers to drive progress in science and industry.

Contact

Address: 3281 E Guasti Rd
Ontario, CA 91761, United States
Phone: (601) 213-4426
Email: info@benchchem.com