

Application Note: Strategic Cleavage of Chiral Auxiliaries

Author: BenchChem Technical Support Team. **Date:** February 2026

Compound of Interest

Compound Name: *(5S)-5-[(1S)-Methylpropyl]-morpholin-3-one*

CAS No.: 160141-20-8

Cat. No.: B1140181

[Get Quote](#)

Strategic Overview

In asymmetric synthesis, the chiral auxiliary is a temporary scaffold. Its value lies not just in the stereochemical induction it provides, but in the fidelity of its removal. A cleavage protocol that degrades the product, causes racemization, or fails to recover the expensive auxiliary renders the entire synthetic sequence commercially and scientifically inviable.

This guide moves beyond textbook definitions to provide field-validated protocols for the three most dominant auxiliary classes in drug development.

The Cleavage Decision Matrix

The choice of cleavage reagent dictates the final functional group.^[1] This decision must be made before the auxiliary is attached.

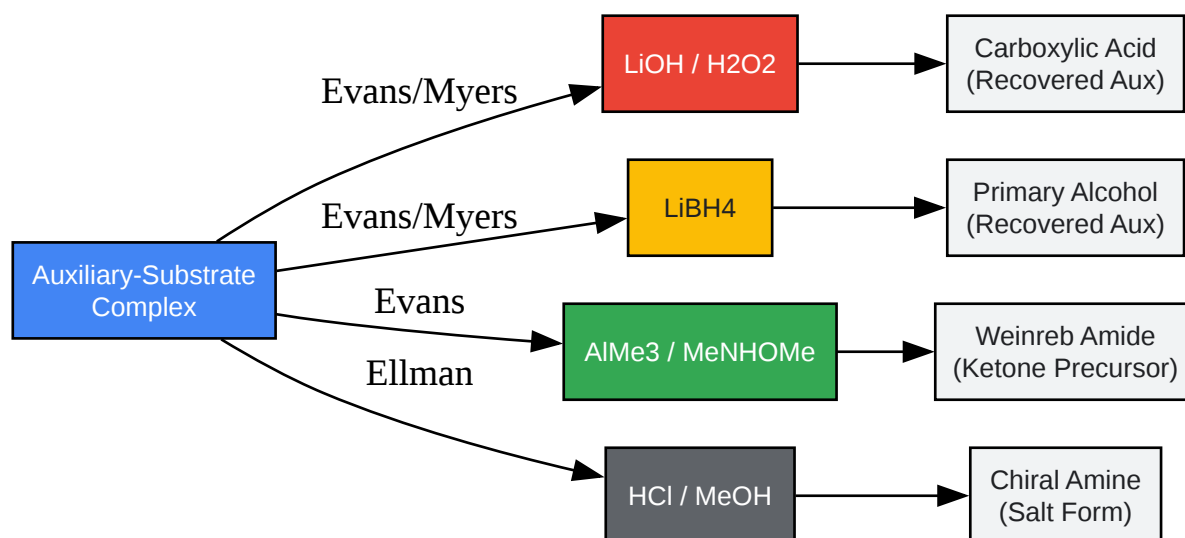

[Click to download full resolution via product page](#)

Figure 1: Strategic decision tree for auxiliary cleavage based on desired target functionality.

Evans Oxazolidinone: The Gold Standard

Target: Production of Chiral Acids, Alcohols, or Weinreb Amides.

A. Hydrolytic Cleavage (LiOH / H₂O₂)

This is the most critical protocol. Standard hydrolysis (LiOH only) often fails due to endocyclic cleavage (attacking the auxiliary carbonyl) or racemization (slow hydrolysis allows enolization).

The Mechanistic Fix: We utilize the peroxide effect. The hydroperoxide anion (HOO⁻) is roughly 100× more nucleophilic than hydroxide (HO⁻) due to the alpha-effect, yet it is significantly less basic (pK_a ~11.6 vs 15.7). This ensures attack occurs at the exocyclic imide carbonyl (product release) rather than the auxiliary carbamate, while suppressing deprotonation at the alpha-center (racemization).

Protocol 1: Peroxide-Assisted Hydrolysis

Standard Scale: 1.0 mmol substrate

- Preparation: Dissolve the acylated oxazolidinone (1.0 equiv) in THF/H₂O (3:1, 0.1 M concentration).

- Cooling: Cool the solution to 0 °C.
 - Critical Control: Do not skip cooling. Higher temperatures promote endocyclic attack.
- Peroxide Addition: Add 30% H₂O₂ (4.0 equiv) dropwise via syringe.
- Base Addition: Add LiOH·H₂O (1.2–1.5 equiv) dissolved in a minimum amount of water.
 - Observation: The reaction typically turns a milky white suspension.
- Monitoring: Stir at 0 °C. Monitor by TLC/HPLC. Conversion is usually complete within 1–3 hours.
- The Quench (Safety Critical):
 - Add saturated aqueous Na₂SO₃ (sodium sulfite) or Na₂S₂O₃ (thiosulfate) dropwise at 0 °C.
 - Checkpoint: Test with starch-iodide paper. It must remain white (no blue/black color), indicating all peroxides are neutralized.
- Workup:
 - Evaporate bulk THF (rotary evaporator, <30 °C).
 - Extract the alkaline aqueous layer with CH₂Cl₂ (3x) to remove the cleaved auxiliary (which is neutral).
 - Acidify the aqueous layer (pH ~2) with 1N HCl.
 - Extract the chiral acid product with EtOAc.

Safety Alert: On scales >10g, the LiOH/H₂O₂ reaction generates O₂ gas due to the decomposition of the peracid intermediate. Ensure adequate venting and inert gas sweep to prevent headspace pressurization [1].

B. Transamidation to Weinreb Amides

Direct conversion to the Weinreb amide is superior to hydrolysis-then-coupling, as it prevents racemization entirely.

Protocol 2: AlMe₃-Mediated Transamidation

- Reagent Formation: In a flame-dried flask under Argon, suspend N,O-dimethylhydroxylamine hydrochloride (3.0 equiv) in dry CH₂Cl₂.
- Activation: Slowly add AlMe₃ (2.0 M in hexanes, 3.0 equiv) at 0 °C.
 - Caution: AlMe₃ is pyrophoric. Methane gas is evolved; allow for venting. Stir for 30 min to form the active aluminum amide species.
- Reaction: Cannulate the solution of acylated oxazolidinone (1.0 equiv in CH₂Cl₂) into the aluminum reagent at 0 °C.
- Workup: Quench carefully with dilute aqueous Rochelle's salt (potassium sodium tartrate) and stir vigorously for 1-2 hours until the aluminum emulsion breaks into two clear layers.

Myers Pseudoephedrine: Industrial Scalability

Target: Alkylation products (alpha-substituted acids).[2] Key Advantage: The auxiliary is highly crystalline, allowing for purification of the intermediate diastereomer by crystallization rather than chromatography.

A. Acidic Hydrolysis & Auxiliary Recovery

Myers' auxiliary is an amine, making it distinct from Evans'. This allows a "pH-switch" recovery that is highly efficient (>95% recovery).

Protocol 3: Acidic Cleavage

- Solvent System: Dissolve amide in 1,4-dioxane.
- Acid Addition: Add an equal volume of 9N H₂SO₄.
- Reflux: Heat to reflux (100–105 °C) for 2–5 hours.
 - Note: The harsh conditions are tolerated because the alkylated center is generally quaternary or sterically protected, reducing racemization risk compared to aldol adducts.
- Product Isolation (Step 1):

- Cool to RT. Dilute with water.[3]
- Extract with EtOAc.[3][4] The chiral acid product is in the organic layer.
- The auxiliary (protonated pseudoephedrine) remains in the aqueous layer.
- Auxiliary Recovery (Step 2):
 - Basify the aqueous layer to pH 14 with 50% NaOH.
 - Extract with CH₂Cl₂.
 - Dry and concentrate to recover pure pseudoephedrine for reuse.

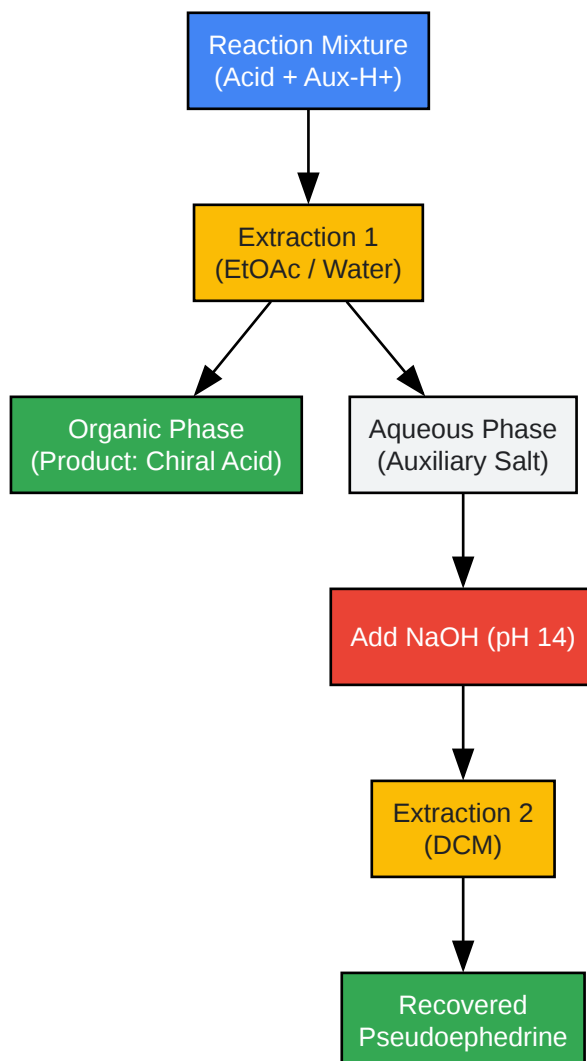

[Click to download full resolution via product page](#)

Figure 2: The pH-switch recovery workflow for Myers Pseudoephedrine.

Ellman Sulfinamide: Synthesis of Chiral Amines

Target: Chiral alpha-branched amines.[5] Mechanism: Acid-mediated N-S bond cleavage.[5][6]

Unlike Evans/Myers, the Ellman auxiliary is often considered "sacrificial" in standard protocols, though the sulfur moiety can be recycled with specialized steps. The priority here is the integrity of the resulting amine salt.

Protocol 4: HCl Cleavage

- Dissolution: Dissolve the sulfinamide diastereomer in MeOH (0.1 M).
- Acidolysis: Add 4N HCl in 1,4-dioxane (2–4 equiv).
 - Alternative: Concentrated aqueous HCl can be used, but anhydrous conditions (dioxane/MeOH) often yield cleaner precipitation of the salt.
- Reaction: Stir at RT for 30 minutes.
 - Validation: Monitor by TLC.[3] The sulfinamide spot will disappear, and a baseline spot (amine salt) will appear.
- Isolation:
 - Add excess Et₂O or MTBE to the reaction mixture.
 - The chiral amine hydrochloride typically precipitates as a white solid.
 - Filter and wash with Et₂O.
 - Yield: This method usually provides quantitative yield of the amine salt.

Troubleshooting & Optimization Data

Table 1: Comparative Cleavage Parameters

Auxiliary	Reagent	Primary Risk	Mitigation Strategy
Evans	LiOH / H ₂ O ₂	Racemization	Keep T < 0°C; Ensure H ₂ O ₂ is fresh (high potency).
Evans	LiBH ₄	Over-reduction	Monitor stoichiometry; use THF/Water (trace) to catalyze.
Myers	H ₂ SO ₄ (Reflux)	Hydrolysis failure	Increase temp; verify dioxane concentration (solubility).
Ellman	HCl / MeOH	By-product trapping	Precipitate amine salt with ether to leave sulfur by-products in solution.

Common Pitfall: The "Stuck" Evans Auxiliary

If LiOH/H₂O₂ fails to cleave a sterically hindered Evans adduct:

- Switch to LiOBn (Lithium Benzyloxide) in THF at -78 °C to 0 °C. This yields the benzyl ester, which can be hydrogenated to the acid.
- Use high-pressure hydrolysis (rare, but effective for quaternary centers).

References

- Evans, D. A., et al. (1982). "Chiral enolates. Asymmetric alkylation reactions with chiral oxazolidinones." *Journal of the American Chemical Society*.^{[2][7]}
- Myers, A. G., et al. (1997). "Pseudoephedrine as a Practical Chiral Auxiliary for the Synthesis of Highly Enantiomerically Enriched Carboxylic Acids, Alcohols, Aldehydes, and Ketones."^{[2][8]} *Journal of the American Chemical Society*.^{[2][7]}
- Ellman, J. A., et al. (2002).^[4] "N-tert-Butanesulfinyl Imines: Versatile Intermediates for the Asymmetric Synthesis of Amines." *Accounts of Chemical Research*.

- Beutner, G. L., et al. (2019). "Revisiting the Cleavage of Evans Oxazolidinones with LiOH/H₂O₂." Organic Process Research & Development.

Need Custom Synthesis?

BenchChem offers custom synthesis for rare earth carbides and specific isotopic labeling.

Email: info@benchchem.com or [Request Quote Online](#).

Sources

- [1. pdf.benchchem.com \[pdf.benchchem.com\]](https://pdf.benchchem.com)
- [2. pubs.acs.org \[pubs.acs.org\]](https://pubs.acs.org)
- [3. pdf.benchchem.com \[pdf.benchchem.com\]](https://pdf.benchchem.com)
- [4. arkat-usa.org \[arkat-usa.org\]](https://arkat-usa.org)
- [5. Modular synthesis of bis- \$\alpha\$ -chiral amines using Ellman sulfinamide for consecutive S-to-C chirality induction/transfer - PMC \[pmc.ncbi.nlm.nih.gov\]](#)
- [6. researchgate.net \[researchgate.net\]](https://researchgate.net)
- [7. pdf.benchchem.com \[pdf.benchchem.com\]](https://pdf.benchchem.com)
- [8. myers.faculty.chemistry.harvard.edu \[myers.faculty.chemistry.harvard.edu\]](https://myers.faculty.chemistry.harvard.edu)
- To cite this document: BenchChem. [Application Note: Strategic Cleavage of Chiral Auxiliaries]. BenchChem, [2026]. [Online PDF]. Available at: [\[https://www.benchchem.com/product/b1140181#cleavage-of-the-chiral-auxiliary-from-the-product\]](https://www.benchchem.com/product/b1140181#cleavage-of-the-chiral-auxiliary-from-the-product)

Disclaimer & Data Validity:

The information provided in this document is for Research Use Only (RUO) and is strictly not intended for diagnostic or therapeutic procedures. While BenchChem strives to provide accurate protocols, we make no warranties, express or implied, regarding the fitness of this product for every specific experimental setup.

Technical Support: The protocols provided are for reference purposes. Unsure if this reagent suits your experiment? [[Contact our Ph.D. Support Team for a compatibility check](#)]

Need Industrial/Bulk Grade? [Request Custom Synthesis Quote](#)

BenchChem

Our mission is to be the trusted global source of essential and advanced chemicals, empowering scientists and researchers to drive progress in science and industry.

Contact

Address: 3281 E Guasti Rd
Ontario, CA 91761, United States
Phone: (601) 213-4426
Email: info@benchchem.com