

An In-depth Technical Guide to Para Red-d4

Author: BenchChem Technical Support Team. **Date:** April 2026

Compound of Interest

Compound Name:	Para Red-d4
CAS No.:	1185235-75-9
Cat. No.:	B1140282

[Get Quote](#)

For Researchers, Scientists, and Drug Development Professionals

This technical guide provides comprehensive information on the molecular properties, synthesis, and a representative experimental workflow for **Para Red-d4**. The data is presented to be a valuable resource for researchers and professionals in the fields of chemistry and drug development.

Core Molecular Data

Para Red-d4 is a deuterated isotopologue of Para Red, a synthetic azo dye. The incorporation of deuterium atoms provides a valuable tool for various analytical and research applications, including metabolic studies and as an internal standard in mass spectrometry.

Property	Value	Citations
Molecular Formula	C ₁₆ H ₇ D ₄ N ₃ O ₃	[1][2]
Molecular Weight	297.30 g/mol	[1][2]
CAS Number	1185235-75-9	[1]
Appearance	Red solid	
Unlabeled CAS	6410-10-2 (Para Red)	

Experimental Protocols: Synthesis of Para Red-d4

The synthesis of **Para Red-d4** is analogous to the well-established synthesis of Para Red, which involves a diazotization reaction followed by an azo coupling. The key modification for the synthesis of **Para Red-d4** is the use of a deuterated precursor, specifically 2-naphthol-d4.

Materials:

- p-Nitroaniline
- Sodium nitrite (NaNO₂)
- Hydrochloric acid (HCl), concentrated
- 2-Naphthol-d4 (β-Naphthol-d4)
- Sodium hydroxide (NaOH)
- Ice
- Distilled water
- Ethanol

Procedure:

Part 1: Diazotization of p-Nitroaniline

- In a flask, dissolve p-nitroaniline in a solution of concentrated hydrochloric acid and water.
- Cool the mixture to 0-5 °C in an ice bath with constant stirring. This low temperature is crucial as the diazonium salt is unstable at higher temperatures.
- Slowly add an aqueous solution of sodium nitrite to the cooled p-nitroaniline solution. The addition should be dropwise to maintain the low temperature.
- Continue stirring for a few minutes after the addition is complete to ensure the full formation of the p-nitrobenzenediazonium chloride solution.

Part 2: Azo Coupling with 2-Naphthol-d4

- In a separate beaker, dissolve 2-naphthol-d4 in an aqueous solution of sodium hydroxide.
- Cool this solution in an ice bath.
- Slowly add the cold diazonium salt solution from Part 1 to the cold 2-naphthol-d4 solution with vigorous stirring.
- A red precipitate of **Para Red-d4** will form immediately.
- Continue stirring for a period to ensure the completion of the reaction.
- Collect the solid product by vacuum filtration and wash it with cold water to remove any unreacted starting materials and salts.
- The crude product can be further purified by recrystallization from a suitable solvent, such as ethanol.

Experimental Workflow Visualization

The following diagram illustrates the synthetic pathway for **Para Red-d4**, detailing the key reactants and intermediate steps.

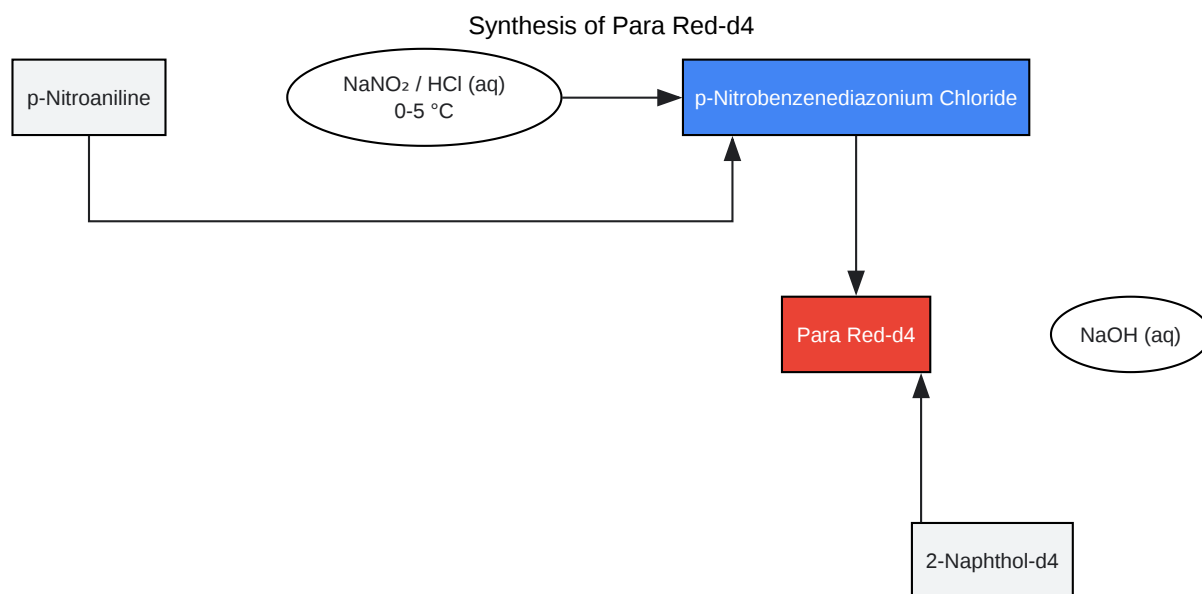

[Click to download full resolution via product page](#)

Synthetic pathway of **Para Red-d4**.

Need Custom Synthesis?

BenchChem offers custom synthesis for rare earth carbides and specific isotopic labeling.

Email: info@benchchem.com or [Request Quote Online](#).

References

- 1. Synthesis of Deuterated Heterocycles with Me₂NCD(OMe)₂ and Evaluation of the Products for Metabolism by Aldehyde Oxidase - PMC [[pmc.ncbi.nlm.nih.gov](https://pubmed.ncbi.nlm.nih.gov/)]
- 2. scispace.com [scispace.com]
- To cite this document: BenchChem. [An In-depth Technical Guide to Para Red-d4]. BenchChem, [2026]. [Online PDF]. Available at: [<https://www.benchchem.com/product/b1140282/docs#an-in-depth-technical-guide-to-para-red-d4>]

Disclaimer & Data Validity:

The information provided in this document is for Research Use Only (RUO) and is strictly not intended for diagnostic or therapeutic procedures. While BenchChem strives to provide accurate protocols, we make no warranties, express or implied, regarding the fitness of this product for every specific experimental setup.

Technical Support: The protocols provided are for reference purposes. Unsure if this reagent suits your experiment?

Need Industrial/Bulk Grade? [Request Custom Synthesis Quote](#)

BenchChem

Our mission is to be the trusted global source of essential and advanced chemicals, empowering scientists and researchers to drive progress in science and industry.

Contact

Address: 3281 E Guasti Rd
Ontario, CA 91761, United States
Phone: (601) 213-4426
Email: info@benchchem.com

[Contact our Ph.D. Support Team for a compatibility check](#)