

# A Comparative Analysis for Researchers and Drug Development Professionals

**Author:** BenchChem Technical Support Team. **Date:** April 2026

## Compound of Interest

Compound Name: Aminopterin  
CAS No.: 1236566-87-2  
Cat. No.: B1146374

[Get Quote](#)

While direct head-to-head experimental studies comparing aminopterin and pemetrexed in lung cancer cell lines are not readily available in the current body of scientific literature, a comprehensive comparative guide can be constructed by synthesizing the known mechanisms of action, biochemical data, and cytotoxic effects of each compound from various studies. This guide provides an objective comparison to inform researchers, scientists, and drug development professionals.

## Introduction to the Antifolates: Aminopterin and Pemetrexed

Aminopterin, a 4-amino derivative of folic acid, was one of the first antifolate agents used in chemotherapy and is a potent inhibitor of dihydrofolate reductase (DHFR).[1][2] Its use was largely supplanted by methotrexate due to a perceived better therapeutic index.[2] Pemetrexed is a newer generation, multi-targeted antifolate that inhibits not only DHFR but also thymidylate synthase (TS) and glycinamide ribonucleotide formyltransferase (GARFT), key enzymes in the de novo biosynthesis of purines and thymidine.[3][4]

## Mechanism of Action: A Tale of Two Inhibition Profiles

Both aminopterin and pemetrexed function by disrupting the folate metabolic pathway, which is crucial for the synthesis of nucleotides, and consequently, DNA and RNA.[1][5] However, their enzymatic inhibition profiles differ significantly.

**Aminopterin:** The primary and most potent target of aminopterin is dihydrofolate reductase (DHFR).[1][2] By competitively inhibiting DHFR, aminopterin blocks the regeneration of tetrahydrofolate (THF) from dihydrofolate (DHF). THF is an essential cofactor for the synthesis of purines and thymidylate. The depletion of the THF pool leads to an inhibition of DNA, RNA, and protein synthesis, ultimately causing cell death.[1][2]

**Pemetrexed:** Pemetrexed boasts a broader mechanism of action by targeting multiple enzymes in the folate pathway:[3][4][6]

- **Thymidylate Synthase (TS):** Pemetrexed is a potent inhibitor of TS, which is a critical enzyme for the synthesis of thymidine, a necessary component of DNA.[4][7]
- **Dihydrofolate Reductase (DHFR):** Similar to aminopterin, pemetrexed also inhibits DHFR, leading to the depletion of THF.[3]
- **Glycinamide Ribonucleotide Formyltransferase (GARFT):** By inhibiting GARFT, pemetrexed disrupts the de novo purine synthesis pathway.[6]

This multi-targeted approach may offer a therapeutic advantage by creating a more comprehensive blockade of nucleotide synthesis.

## Quantitative Data Presentation

The following tables summarize the available quantitative data for aminopterin and pemetrexed. It is important to note that the data is compiled from different studies and experimental conditions, and direct comparisons should be made with caution.

### Table 1: Comparative Enzyme Inhibition

Drug	Target Enzyme	Organism/Source	Ki Value
Aminopterin	Dihydrofolate Reductase (DHFR)	Not Specified	3.7 pM[1][8]
Dihydrofolate Reductase (DHFR)	Human	34 pM[9]	
Pemetrexed	Dihydrofolate Reductase (DHFR)	Not Specified	-
Thymidylate Synthase (TS)	Not Specified	-	
Glycinamide Ribonucleotide Formyltransferase (GARFT)	Not Specified	-	

Note: Specific Ki values for pemetrexed's inhibition of human DHFR, TS, and GARFT were not readily available in the provided search results. Pemetrexed is known to be a potent inhibitor of these enzymes.

## Table 2: Comparative In Vitro Cytotoxicity (IC50 Values)

Drug	Cell Line	Cancer Type	IC50 Value (nM)
Aminopterin	CCRF-CEM	Pediatric Leukemia	4.4[1]
Various Leukemia/Lymphoma Lines	Pediatric Leukemia/Lymphoma	Median: 17[10]	
Pemetrexed	A549	Non-Small Cell Lung Cancer	~10,000 (at 24h)[11]
PC9	Non-Small Cell Lung Cancer	-	
NCI-H460	Non-Small Cell Lung Cancer	-	
NCI-H2228	Non-Small Cell Lung Cancer	-	
NCI-H3122	Non-Small Cell Lung Cancer	-	

Note: The IC50 values are highly dependent on the experimental conditions, including the duration of drug exposure. The provided IC50 for pemetrexed in A549 cells is an approximation from a graphical representation at a 24-hour time point. Other studies show varying sensitivities of different NSCLC cell lines to pemetrexed.

## Experimental Protocols

Detailed methodologies for key experiments cited in the comparison are provided below.

### In Vitro Cytotoxicity Assay (MTT Assay)

This assay is a colorimetric method used to assess cell viability.

- **Cell Seeding:** Cancer cells (e.g., A549 lung cancer cells) are seeded into 96-well plates at a predetermined density (e.g., 5,000 cells/well) and allowed to adhere overnight.

- **Drug Treatment:** The following day, the culture medium is replaced with fresh medium containing serial dilutions of either aminopterin or pemetrexed. A control group with no drug is also included.
- **Incubation:** The plates are incubated for a specified period (e.g., 72 hours) at 37°C in a humidified atmosphere with 5% CO<sub>2</sub>.
- **MTT Addition:** After the incubation period, a solution of 3-(4,5-dimethylthiazol-2-yl)-2,5-diphenyltetrazolium bromide (MTT) is added to each well, and the plates are incubated for an additional 2-4 hours.
- **Formazan Solubilization:** The medium is removed, and a solubilizing agent (e.g., DMSO) is added to dissolve the formazan crystals formed by metabolically active cells.
- **Absorbance Measurement:** The absorbance is measured at a specific wavelength (e.g., 570 nm) using a microplate reader.
- **Data Analysis:** The cell viability is calculated as a percentage of the control group, and the IC<sub>50</sub> value (the concentration of the drug that inhibits cell growth by 50%) is determined.[\[12\]](#)  
[\[13\]](#)[\[14\]](#)

## Dihydrofolate Reductase (DHFR) Inhibition Assay

This spectrophotometric assay measures the activity of DHFR.

- **Reaction Mixture Preparation:** A reaction buffer is prepared containing a suitable buffer (e.g., Tris-HCl), dithiothreitol (DTT), and the substrates dihydrofolate (DHF) and NADPH.
- **Enzyme and Inhibitor Incubation:** Purified human DHFR enzyme is pre-incubated with varying concentrations of the inhibitor (aminopterin or pemetrexed) in the reaction buffer.
- **Reaction Initiation:** The reaction is initiated by the addition of the substrates.
- **Kinetic Measurement:** The decrease in absorbance at 340 nm, corresponding to the oxidation of NADPH to NADP<sup>+</sup>, is monitored over time using a spectrophotometer.
- **Data Analysis:** The initial reaction velocities are calculated for each inhibitor concentration. The percentage of inhibition is plotted against the inhibitor concentration to determine the

IC50 or Ki value.[\[15\]](#)[\[16\]](#)[\[17\]](#)

## Thymidylate Synthase (TS) Inhibition Assay

This assay measures the activity of TS.

- **Reaction Mixture Preparation:** A reaction mixture is prepared containing a buffer, the substrate deoxyuridine monophosphate (dUMP), and the cofactor 5,10-methylenetetrahydrofolate.
- **Enzyme and Inhibitor Incubation:** Purified human TS enzyme is pre-incubated with varying concentrations of the inhibitor (pemetrexed).
- **Spectrophotometric Measurement:** The increase in absorbance at 340 nm, corresponding to the conversion of 5,10-methylenetetrahydrofolate to dihydrofolate, is monitored over time.
- **Data Analysis:** The rate of the reaction is determined from the change in absorbance, and the inhibitory activity of the compound is calculated.[\[18\]](#)[\[19\]](#)

## Visualizations

### Folate Metabolism and Antifolate Inhibition

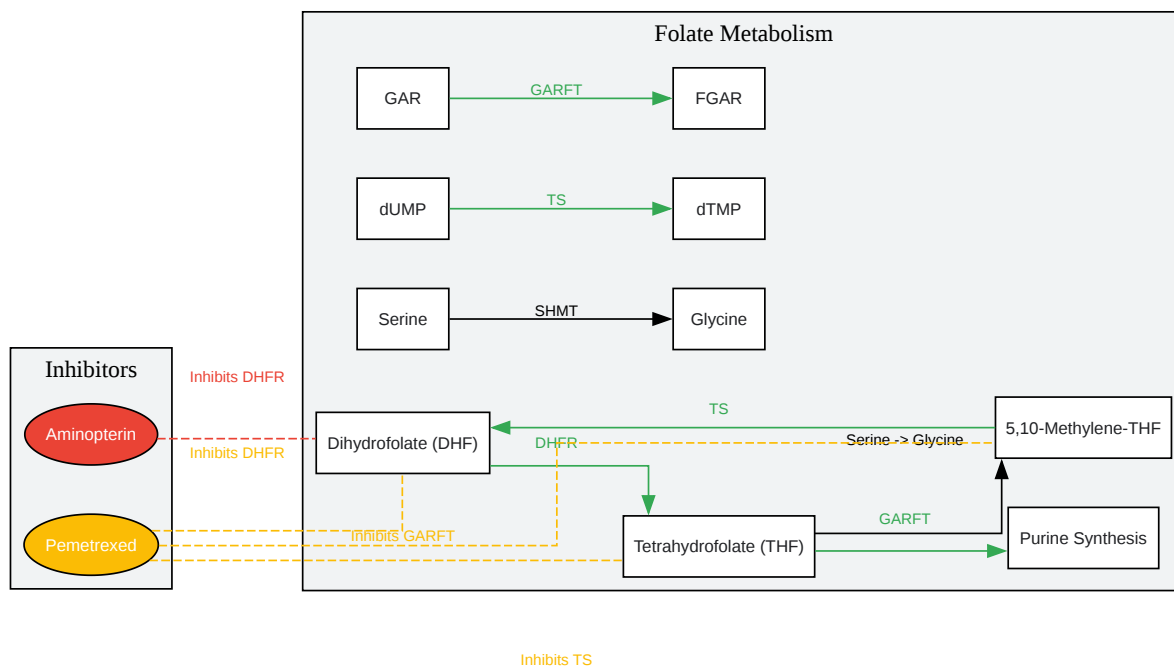

[Click to download full resolution via product page](#)

Caption: Folate metabolism pathway and points of inhibition by Aminopterin and Pemetrexed.

## General Experimental Workflow for In Vitro Drug Comparison

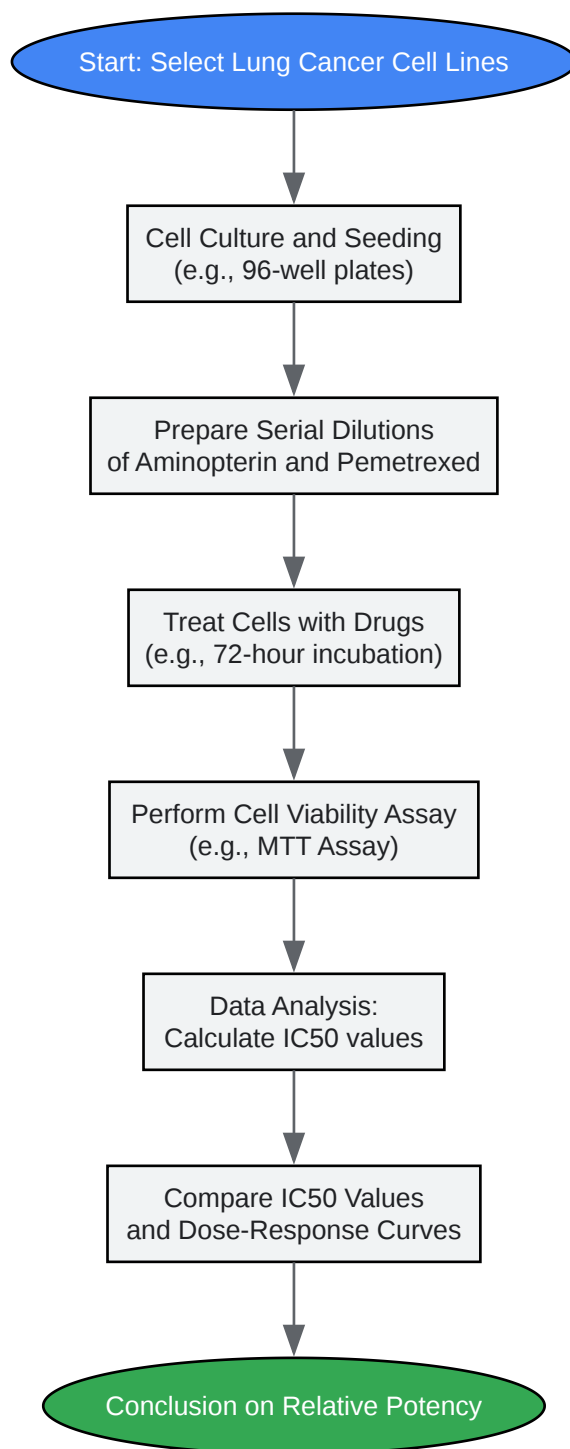

[Click to download full resolution via product page](#)

Caption: A generalized workflow for comparing the in vitro cytotoxicity of two compounds.

### Need Custom Synthesis?

BenchChem offers custom synthesis for rare earth carbides and specific isotopic labeling.

Email: [info@benchchem.com](mailto:info@benchchem.com) or [Request Quote Online](#).

## References

- [1. medchemexpress.com \[medchemexpress.com\]](https://www.medchemexpress.com)
- [2. Aminopterin - Wikipedia \[en.wikipedia.org\]](https://en.wikipedia.org)
- [3. The role of Pemetrexed \(Alimta , LY231514\) in lung cancer therapy - PubMed \[pubmed.ncbi.nlm.nih.gov\]](https://pubmed.ncbi.nlm.nih.gov)
- [4. Pemetrexed: its promise in treating non-small-cell lung cancer - PubMed \[pubmed.ncbi.nlm.nih.gov\]](https://pubmed.ncbi.nlm.nih.gov)
- [5. Chemotherapy - Wikipedia \[en.wikipedia.org\]](https://en.wikipedia.org)
- [6. The role of pemetrexed in advanced non small-cell lung cancer: special focus on pharmacology and mechanism of action - PubMed \[pubmed.ncbi.nlm.nih.gov\]](https://pubmed.ncbi.nlm.nih.gov)
- [7. The pemetrexed-containing treatments in the non-small cell lung cancer, is -/low thymidylate synthase expression better than +/high thymidylate synthase expression: a meta-analysis - PMC \[pmc.ncbi.nlm.nih.gov\]](https://pubmed.ncbi.nlm.nih.gov)
- [8. selleckchem.com \[selleckchem.com\]](https://www.selleckchem.com)
- [9. pubs.acs.org \[pubs.acs.org\]](https://pubs.acs.org)
- [10. Clinical potency of methotrexate, aminopterin, talotrexin and pemetrexed in childhood leukemias - PubMed \[pubmed.ncbi.nlm.nih.gov\]](https://pubmed.ncbi.nlm.nih.gov)
- [11. researchgate.net \[researchgate.net\]](https://www.researchgate.net)
- [12. benchchem.com \[benchchem.com\]](https://www.benchchem.com)
- [13. benchchem.com \[benchchem.com\]](https://www.benchchem.com)
- [14. benchchem.com \[benchchem.com\]](https://www.benchchem.com)
- [15. benchchem.com \[benchchem.com\]](https://www.benchchem.com)
- [16. DHFR Enzyme Inhibition assay \[bio-protocol.org\]](https://www.biorxiv.org)
- [17. scispace.com \[scispace.com\]](https://www.scispace.com)

- [18. Rapid determination of thymidylate synthase activity and its inhibition in intact L1210 leukemia cells in vitro - PubMed \[pubmed.ncbi.nlm.nih.gov\]](#)
- [19. Cooperative Inhibition of Human Thymidylate Synthase by Mixtures of Active Site Binding and Allosteric Inhibitors - PMC \[pmc.ncbi.nlm.nih.gov\]](#)
- To cite this document: BenchChem. [A Comparative Analysis for Researchers and Drug Development Professionals]. BenchChem, [2026]. [Online PDF]. Available at: [\[https://www.benchchem.com/product/b1146374/docs#a-comparative-analysis-for-researchers-and-drug-development-professionals\]](https://www.benchchem.com/product/b1146374/docs#a-comparative-analysis-for-researchers-and-drug-development-professionals)

---

**Disclaimer & Data Validity:**

The information provided in this document is for Research Use Only (RUO) and is strictly not intended for diagnostic or therapeutic procedures. While BenchChem strives to provide accurate protocols, we make no warranties, express or implied, regarding the fitness of this product for every specific experimental setup.

**Technical Support:** The protocols provided are for reference purposes. Unsure if this reagent suits your experiment?

**Need Industrial/Bulk Grade?** [Request Custom Synthesis Quote](#)

## BenchChem

Our mission is to be the trusted global source of essential and advanced chemicals, empowering scientists and researchers to drive progress in science and industry.

### Contact

Address: 3281 E Guasti Rd  
Ontario, CA 91761, United States  
Phone: (601) 213-4426  
Email: [info@benchchem.com](mailto:info@benchchem.com)

[Contact our Ph.D. Support Team for a compatibility check](#)

