

Tertiapin-Q: A Technical Guide to its Interaction with Target Ion Channels

Author: BenchChem Technical Support Team. **Date:** April 2026

Compound of Interest

Compound Name: *tertiapin-Q*
CAS No.: 252198-49-5
Cat. No.: B1139123

[Get Quote](#)

For Researchers, Scientists, and Drug Development Professionals

Introduction

Tertiapin-Q (TPN-Q) is a synthetic, oxidation-resistant analog of tertiapin, a 21-amino acid peptide originally isolated from the venom of the European honey bee (*Apis mellifera*). The substitution of methionine at position 13 with glutamine confers stability to the peptide without compromising its biological activity, making it a valuable tool for neuropharmacology and cardiovascular research.^[1] This technical guide provides an in-depth overview of **Tertiapin-Q**'s target ion channels, binding sites, and the experimental methodologies used to characterize these interactions.

Target Ion Channels and Binding Affinity

Tertiapin-Q is a potent blocker of specific subtypes of inwardly rectifying potassium (Kir) channels and large-conductance calcium-activated potassium (BK) channels.^{[1][2]} Its high affinity and selectivity for certain channel subtypes make it a critical pharmacological probe for dissecting the physiological roles of these channels.

Quantitative Binding Data

The binding affinities of **Tertiapin-Q** for its primary molecular targets have been quantified using various experimental techniques, including electrophysiology and radioligand binding assays. The following tables summarize the key quantitative data.

Target Ion Channel	Subunits	Alternative Names	Binding Affinity (Ki)	IC50	Species	Experimental System	Reference
Kir1.1	KCNJ1	ROMK1	1.3 nM	[3]			
Kir3.1/3.4	KCNJ3/KCNJ5	GIRK1/4, IKACH	13.3 nM	~8 nM	Rabbit	Cardiac Myocytes	[3][4]
Kir3.1/3.2	KCNJ3/KCNJ6	GIRK1/2	~270 nM (Kd)	Mouse	Xenopus Oocytes	[5]	
BK Channel	KCNMA1	MaxiK, Slo1	~5.8 nM	Human	Xenopus Oocytes	[1][5]	

Note: Ki (inhibition constant) and IC50 (half-maximal inhibitory concentration) values are measures of binding affinity and potency, respectively. Kd (dissociation constant) is another measure of affinity.

Binding Sites and Mechanism of Action

Inwardly Rectifying Potassium (Kir) Channels

Tertiapin-Q physically occludes the pore of Kir channels.[1] Mutagenesis studies have revealed that the C-terminal α -helix of **Tertiapin-Q** inserts into the external vestibule of the channel, thereby blocking the conduction of potassium ions.[6][7] The interaction is stoichiometric, with one molecule of **Tertiapin-Q** binding to one channel tetramer.[6][8] Specific residues in the pore-forming region of the Kir channel are critical for this interaction.

Large-Conductance Calcium-Activated Potassium (BK) Channels

The blockade of BK channels by **Tertiapin-Q** is more complex, exhibiting voltage, concentration, and use-dependence.[2][9] This suggests a different binding mechanism compared to its interaction with Kir channels. The blockade is more pronounced with repeated channel activation, indicating that the binding site may become more accessible when the channel is in an open or activated state.[2]

Signaling Pathways

The ion channels targeted by **Tertiapin-Q** are integral components of crucial signaling pathways in various cell types, particularly in the nervous and cardiovascular systems.

GIRK Channel Signaling in Neurons

G-protein coupled inwardly rectifying potassium (GIRK) channels are key effectors in inhibitory neurotransmission.[2][6] They are activated by G $\beta\gamma$ subunits released from Gi/o-coupled receptors upon binding of neurotransmitters like GABA (via GABAB receptors), dopamine (via D2 receptors), and acetylcholine (via M2 receptors).[6] Activation of GIRK channels leads to an efflux of K⁺, hyperpolarizing the neuron and making it less likely to fire an action potential.

Tertiapin-Q blocks this inhibitory effect.

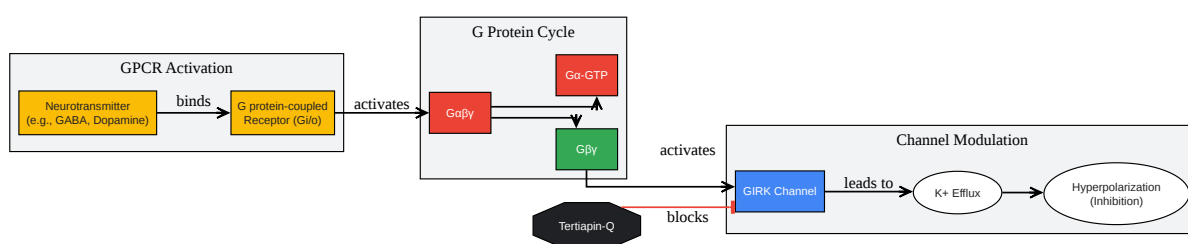

[Click to download full resolution via product page](#)

GIRK Channel Signaling Pathway

BK Channel Role in Neuronal Action Potential

BK channels are activated by both membrane depolarization and intracellular calcium, positioning them to regulate neuronal excitability.[1] They contribute to the repolarization phase of the action potential and the subsequent fast afterhyperpolarization (AHP).[8][9] By blocking BK channels, **Tertiapin-Q** can prolong the action potential duration and reduce the AHP, leading to increased neuronal excitability.[2]

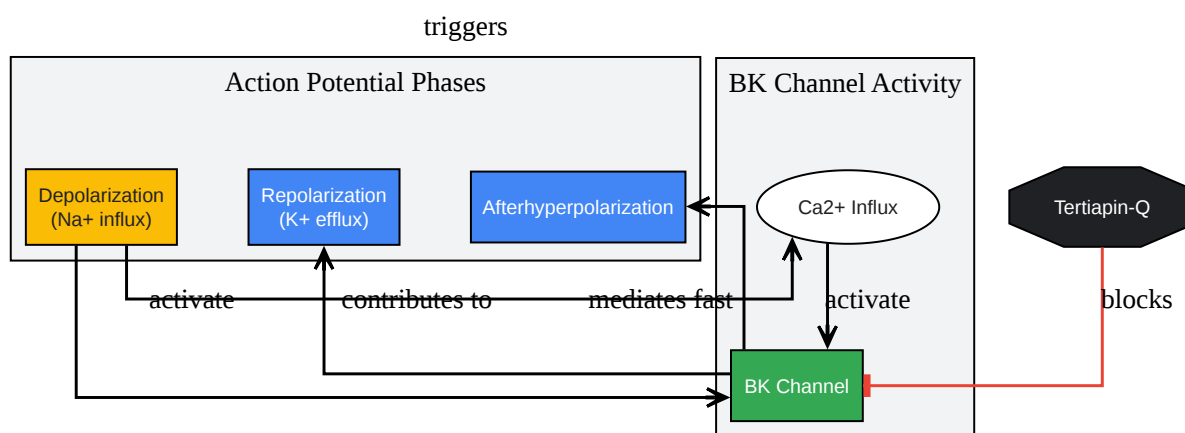

[Click to download full resolution via product page](#)

Role of BK Channels in Action Potentials

Experimental Protocols

The characterization of **Tertiapin-Q**'s interaction with ion channels relies on several key experimental techniques.

Two-Electrode Voltage Clamp (TEVC) in Xenopus Oocytes

This technique is widely used for the heterologous expression and functional characterization of ion channels.

1. Oocyte Preparation and cRNA Injection:

- Harvest oocytes from female *Xenopus laevis* frogs.
- Defolliculate the oocytes by enzymatic digestion (e.g., with collagenase).
- Inject cRNA encoding the ion channel subunits of interest into the oocyte cytoplasm using a nanoliter injector.
- Incubate the injected oocytes for 2-5 days to allow for channel expression.

2. Electrophysiological Recording:

- Place an oocyte in a recording chamber continuously perfused with a standard bath solution (e.g., ND96).
- Impale the oocyte with two microelectrodes filled with 3 M KCl, one for voltage sensing and one for current injection.
- Clamp the membrane potential at a holding potential (e.g., -80 mV).
- Apply a series of voltage steps to elicit ion channel currents.
- Record currents in the absence and presence of various concentrations of **Tertiapin-Q** to determine its inhibitory effect.

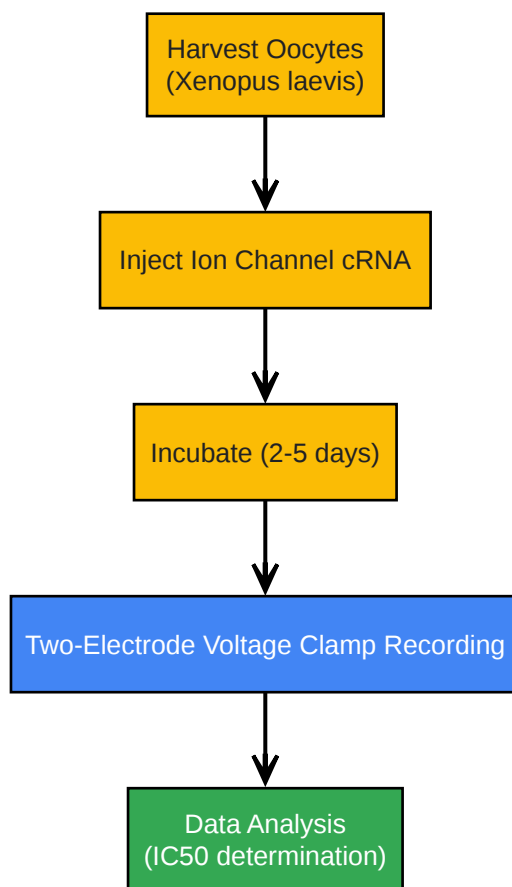

[Click to download full resolution via product page](#)

TEVC Experimental Workflow

Patch-Clamp Electrophysiology

Patch-clamp allows for the recording of ion channel activity from a small patch of membrane or the whole cell.

1. Cell Preparation:

- Culture mammalian cells (e.g., HEK293, CHO) or use primary cells (e.g., neurons, cardiomyocytes).
- Transfect cells with plasmids encoding the ion channel of interest, if not endogenously expressed.

2. Recording:

- Position a fire-polished glass micropipette filled with an appropriate internal solution onto the surface of a cell.
- Apply gentle suction to form a high-resistance (gigaohm) seal between the pipette tip and the cell membrane.
- To achieve the whole-cell configuration, apply a brief pulse of suction to rupture the membrane patch.
- Clamp the cell at a desired voltage and apply voltage protocols to elicit currents.
- Perfuse the cell with an external solution containing **Tertiapin-Q** to measure its effect on channel activity.

Site-Directed Mutagenesis

This technique is used to identify specific amino acid residues involved in the binding of **Tertiapin-Q** to the ion channel.

1. Mutagenesis:

- Start with a plasmid containing the wild-type cDNA of the ion channel subunit.
- Design primers containing the desired mutation.
- Use PCR to amplify the entire plasmid, incorporating the mutagenic primers.
- Digest the parental, non-mutated DNA with a methylation-sensitive restriction enzyme (e.g., DpnI).
- Transform the mutated plasmid into competent *E. coli* for amplification.

2. Functional Analysis:

- Isolate the mutated plasmid DNA and verify the mutation by sequencing.
- Express the mutated channel in an appropriate system (e.g., *Xenopus* oocytes or mammalian cells).

- Use electrophysiology (TEVC or patch-clamp) to assess the effect of the mutation on the binding affinity of **Tertiapin-Q**. A significant change in affinity suggests the mutated residue is involved in binding.

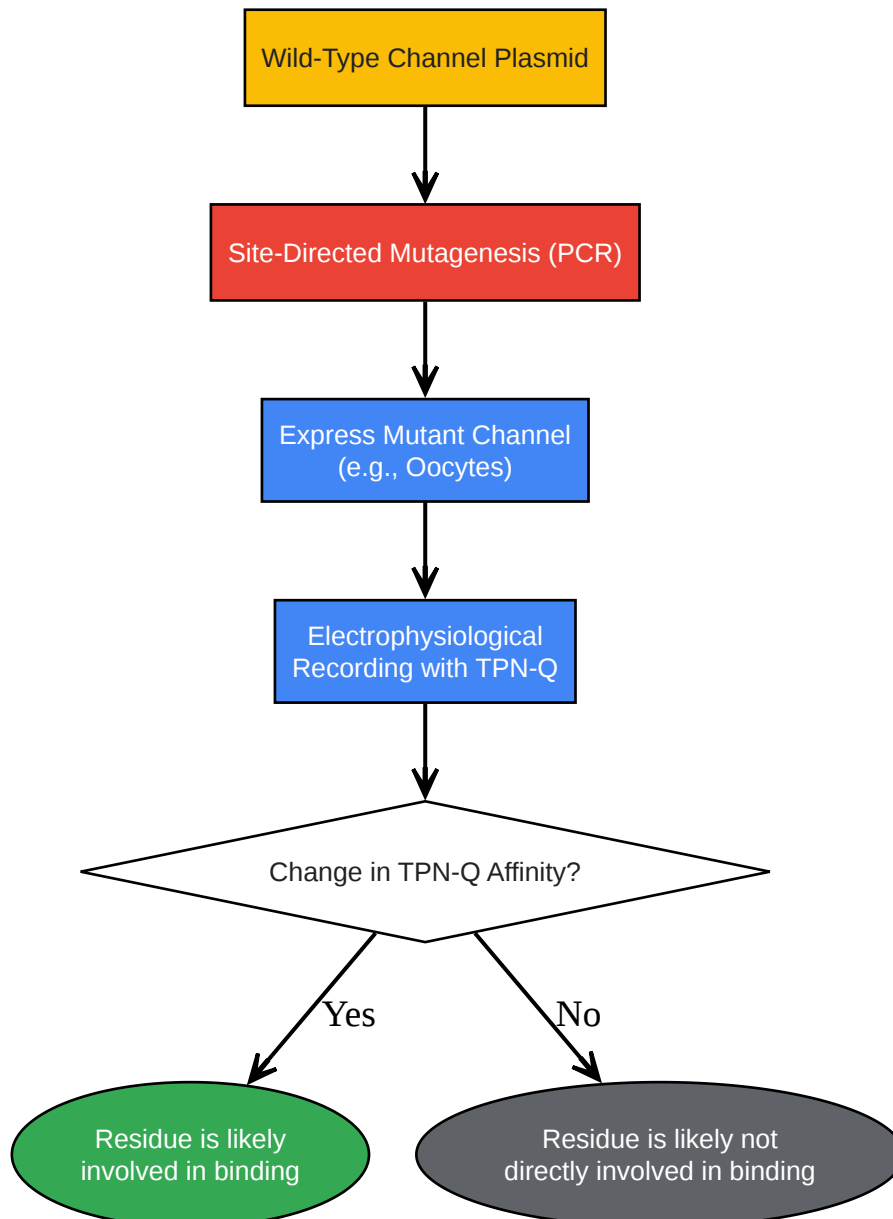

[Click to download full resolution via product page](#)

Logic of Site-Directed Mutagenesis Studies

Conclusion

Tertiapin-Q is a highly valuable pharmacological tool for the study of Kir and BK potassium channels. Its stability and well-characterized interactions with these channels allow researchers to probe their physiological and pathophysiological roles with high precision. The experimental methodologies outlined in this guide provide a framework for further investigation into the molecular pharmacology of **Tertiapin-Q** and the development of novel therapeutics targeting these important ion channels.

Need Custom Synthesis?

BenchChem offers custom synthesis for rare earth carbides and specific isotopic labeling.

Email: info@benchchem.com or [Request Quote Online](#).

References

- [1. BK Channels in the Central Nervous System - PMC \[pmc.ncbi.nlm.nih.gov\]](#)
- [2. Emerging concepts for G protein-gated inwardly rectifying potassium \(GIRK\) channels in health and disease - PMC \[pmc.ncbi.nlm.nih.gov\]](#)
- [3. Tertiapin-Q | Inward Rectifier Potassium \(Kir\) Channels | Tocris Bioscience \[tocris.com\]](#)
- [4. Tertiapin potently and selectively blocks muscarinic K\(+\) channels in rabbit cardiac myocytes - PubMed \[pubmed.ncbi.nlm.nih.gov\]](#)
- [5. Direct modulation of G protein-gated inwardly rectifying potassium \(GIRK\) channels - PMC \[pmc.ncbi.nlm.nih.gov\]](#)
- [6. G protein-coupled inwardly rectifying potassium channel - Wikipedia \[en.wikipedia.org\]](#)
- [7. researchgate.net \[researchgate.net\]](#)
- [8. BK channel - Wikipedia \[en.wikipedia.org\]](#)
- [9. mdpi.com \[mdpi.com\]](#)
- To cite this document: BenchChem. [Tertiapin-Q: A Technical Guide to its Interaction with Target Ion Channels]. BenchChem, [2026]. [Online PDF]. Available at: [\[https://www.benchchem.com/product/b1139123/docs#tertiapin-q-a-technical-guide-to-its-interaction-with-target-ion-channels\]](https://www.benchchem.com/product/b1139123/docs#tertiapin-q-a-technical-guide-to-its-interaction-with-target-ion-channels)

Disclaimer & Data Validity:

The information provided in this document is for Research Use Only (RUO) and is strictly not intended for diagnostic or therapeutic procedures. While BenchChem strives to provide accurate protocols, we make no warranties, express or implied, regarding the fitness of this product for every specific experimental setup.

Technical Support: The protocols provided are for reference purposes. Unsure if this reagent suits your experiment?

Need Industrial/Bulk Grade? [Request Custom Synthesis Quote](#)

BenchChem

Our mission is to be the trusted global source of essential and advanced chemicals, empowering scientists and researchers to drive progress in science and industry.

Contact

Address: 3281 E Guasti Rd
Ontario, CA 91761, United States
Phone: (601) 213-4426
Email: info@benchchem.com

[Contact our Ph.D. Support Team for a compatibility check](#)