

Technical Support Center: Use-Dependent Block of BK Channels by Tertiapin-Q

Author: BenchChem Technical Support Team. **Date:** April 2026

Compound of Interest

Compound Name: *tertiapin-Q*
CAS No.: 252198-49-5
Cat. No.: B1139123

[Get Quote](#)

This technical support center provides troubleshooting guides and frequently asked questions (FAQs) for researchers, scientists, and drug development professionals investigating the use-dependent block of large-conductance Ca²⁺-activated potassium (BK) channels by **tertiapin-Q**.

Frequently Asked Questions (FAQs)

Q1: What is **tertiapin-Q** and what is its primary mechanism of action on BK channels?

Tertiapin-Q is a synthetic, non-oxidizable derivative of tertiapin, a 21-amino acid peptide originally isolated from the venom of the European honey bee (*Apis mellifera*).^[1] Its primary mechanism of action on BK channels is a use-dependent, concentration-dependent, and voltage-dependent block.^{[2][3]} This means that the inhibitory effect of **tertiapin-Q** is more pronounced when the BK channels are repeatedly activated or opened.^{[1][2]}

Q2: Is **tertiapin-Q** a specific blocker for BK channels?

No, **tertiapin-Q** is not entirely specific for BK channels. It is also a potent blocker of certain inwardly rectifying potassium (Kir) channels, including GIRK1/GIRK4 and ROMK1 channels.^[1]

[2][4][5][6] This is a critical consideration when designing experiments and interpreting data, as effects observed could be due to the inhibition of Kir channels.

Q3: What does "use-dependent block" mean in the context of **tertiapin-Q** and BK channels?

Use-dependent block signifies that the blocking action of **tertiapin-Q** on BK channels is contingent upon the channels being in an activated or open state.[2][3] If the channels are not stimulated to open, **tertiapin-Q** will exhibit little to no inhibitory effect.[2] The block intensifies with prolonged or repetitive stimulation.[1][2]

Q4: What are the typical effective concentrations and IC50 for **tertiapin-Q** on BK channels?

The half-maximal inhibitory concentration (IC50) for **tertiapin-Q** on recombinant BK channels (α -subunit homomultimers) expressed in *Xenopus* oocytes has been reported to be approximately 5.8 ± 1.0 nM.[2] A complete block can be observed at concentrations around 100 nM.[2]

Troubleshooting Guide

Issue	Possible Cause	Recommended Solution
<p>No observable block of BK channels after applying tertiapin-Q.</p>	<p>Lack of channel activation (use-dependence). Tertiapin-Q requires the BK channels to be open to exert its blocking effect.[2]</p>	<p>Ensure your experimental protocol includes repetitive stimulation (e.g., depolarizing voltage steps) to activate the BK channels in the presence of tertiapin-Q. A stimulation frequency of 0.1 Hz has been used effectively.[2]</p>
<p>Incorrect concentration of tertiapin-Q.</p>	<p>Confirm the final concentration of tertiapin-Q in your bath solution. Prepare fresh dilutions from a concentrated stock solution for each experiment.</p>	
<p>Degradation of tertiapin-Q.</p>	<p>Although tertiapin-Q is a stable derivative of tertiapin, improper storage can lead to degradation. Store the peptide at -20°C as a powder and for up to one year at -80°C in stock solutions to avoid repeated freeze-thaw cycles. [4]</p>	
<p>Observed effects are not consistent with BK channel blockade.</p>	<p>Off-target effects on Kir channels. Tertiapin-Q is also a potent inhibitor of Kir channels. [1][2][4]</p>	<p>To confirm that the observed effects are due to BK channel blockade, use other more specific BK channel blockers like iberiotoxin or charybdotoxin as controls.[2] Additionally, if your preparation expresses Kir channels, consider using experimental conditions that minimize their</p>

contribution to the recorded currents.

Variability in the degree of block between experiments.

Differences in stimulation protocols. The extent of use-dependent block is sensitive to the frequency and duration of stimulation.

Standardize your stimulation protocol across all experiments to ensure reproducibility.

pH of the extracellular solution. The binding of tertiapin-Q to some Kir channels can be pH-dependent.^[7] While the effect of pH on BK channel block by tertiapin-Q is less characterized, it is good practice to maintain a stable pH in your recordings.

Ensure your extracellular solutions are adequately buffered and the pH is consistent across experiments.

Quantitative Data Summary

Parameter	Value	Channel Type	Expression System	Reference
IC50	5.8 ± 1.0 nM	Recombinant BK channels (α -subunit homomultimers)	Xenopus oocytes	[2]
Complete Block	~100 nM	Recombinant BK channels (α -subunit homomultimers)	Xenopus oocytes	[2]
Ki (ROMK1)	1.3 nM	Inwardly rectifying K ⁺ channel (Kir1.1)	Not specified	[4]
Ki (GIRK1/4)	13.3 nM	G protein-coupled inwardly rectifying K ⁺ channel (Kir3.1/3.4)	Not specified	[4]

Experimental Protocols

Two-Electrode Voltage-Clamp (TEVC) Recording in Xenopus Oocytes

This protocol is adapted from studies investigating the block of recombinant BK channels by **tertiapin-Q**.[\[2\]](#)[\[8\]](#)

- Oocyte Preparation:
 - Harvest and defolliculate *Xenopus laevis* oocytes.
 - Inject cRNA encoding the desired BK channel subunits (e.g., hSlo1 α -subunit).
 - Incubate the oocytes for 2-4 days at 18°C to allow for channel expression.

- Recording Setup:
 - Place an oocyte in a recording chamber continuously perfused with a standard extracellular solution (e.g., ND96).
 - Impale the oocyte with two glass microelectrodes (0.5-2 M Ω resistance) filled with 3 M KCl. One electrode serves to measure the membrane potential, and the other to inject current.
 - Use a two-electrode voltage-clamp amplifier to control the membrane potential.
- Electrophysiological Recording:
 - Hold the oocyte at a holding potential of -80 mV.
 - To elicit BK channel currents, apply depolarizing voltage steps (e.g., 100 ms duration, from -80 mV to +80 mV in 10 mV increments).
 - To study the use-dependent block, apply repetitive depolarizing pulses at a set frequency (e.g., 0.1 Hz).
- Application of **Tertiapin-Q**:
 - Dissolve **tertiapin-Q** in the extracellular solution to the desired final concentration.
 - After obtaining a stable baseline recording of BK currents, perfuse the recording chamber with the **tertiapin-Q**-containing solution.
 - Continue the repetitive stimulation protocol during the application of **tertiapin-Q** to observe the development of the use-dependent block.
- Data Analysis:
 - Measure the peak outward current at a specific voltage step (e.g., +80 mV) before and after the application of **tertiapin-Q**.
 - Plot the concentration-response curve to determine the IC₅₀ value.

Visualizations

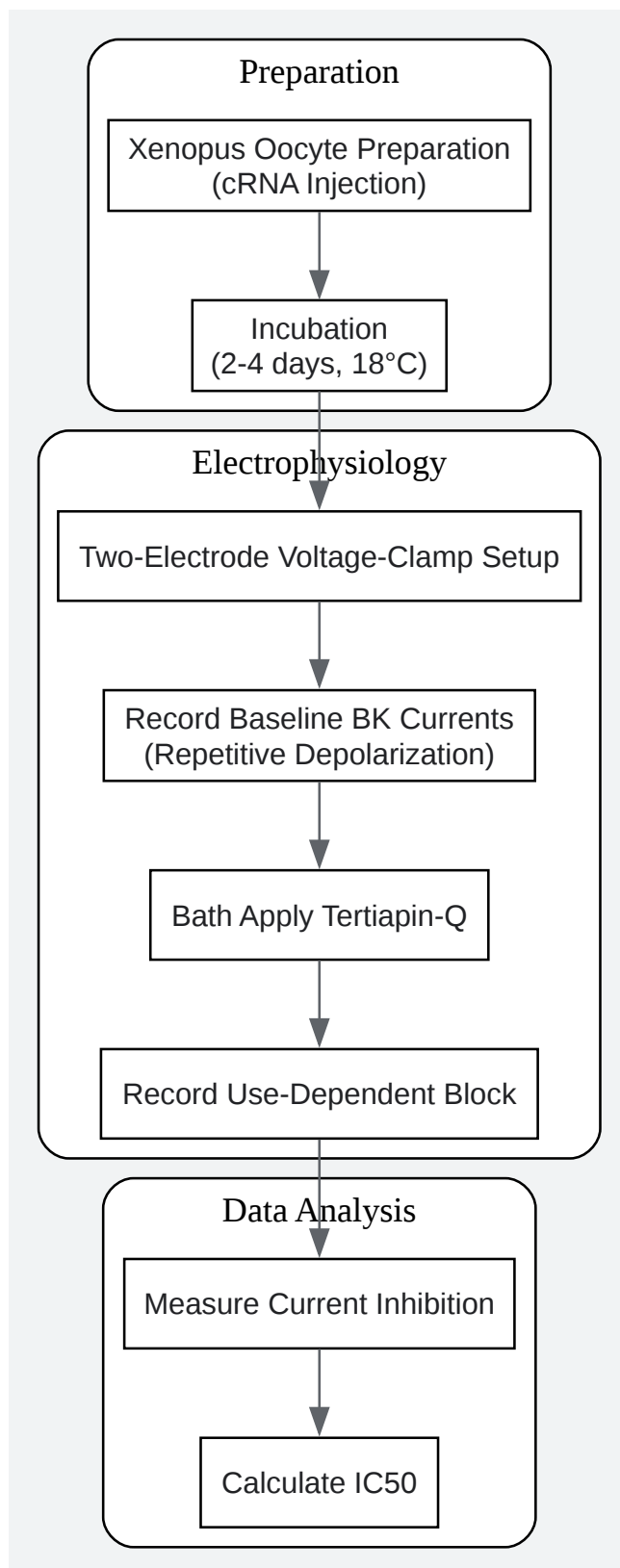

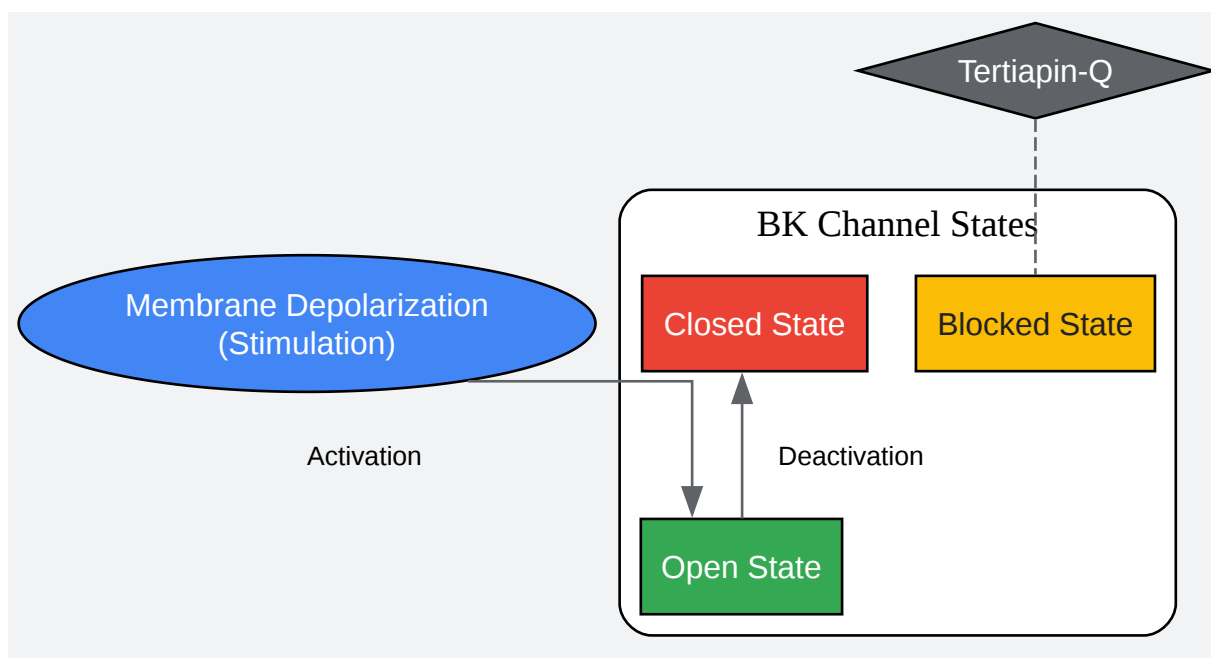

[Click to download full resolution via product page](#)

Need Custom Synthesis?

BenchChem offers custom synthesis for rare earth carbides and specific isotopic labeling.

Email: info@benchchem.com or [Request Quote Online](#).

References

- [1. Tertiapin - Wikipedia \[en.wikipedia.org\]](#)
- [2. Redirecting \[linkinghub.elsevier.com\]](#)
- [3. Tertiapin-Q blocks recombinant and native large conductance K⁺ channels in a use-dependent manner - PubMed \[pubmed.ncbi.nlm.nih.gov\]](#)
- [4. selleckchem.com \[selleckchem.com\]](#)
- [5. Mechanisms of inward-rectifier K⁺ channel inhibition by tertiapin-Q - PubMed \[pubmed.ncbi.nlm.nih.gov\]](#)
- [6. pubs.acs.org \[pubs.acs.org\]](#)
- [7. Titration of tertiapin-Q inhibition of ROMK1 channels by extracellular protons - PubMed \[pubmed.ncbi.nlm.nih.gov\]](#)
- [8. researchgate.net \[researchgate.net\]](#)

- To cite this document: BenchChem. [Technical Support Center: Use-Dependent Block of BK Channels by Tertiapin-Q]. BenchChem, [2026]. [Online PDF]. Available at: [<https://www.benchchem.com/product/b1139123/docs#technical-support-center-use-dependent-block-of-bk-channels-by-tertiapin-q>]

Disclaimer & Data Validity:

The information provided in this document is for Research Use Only (RUO) and is strictly not intended for diagnostic or therapeutic procedures. While BenchChem strives to provide accurate protocols, we make no warranties, express or implied, regarding the fitness of this product for every specific experimental setup.

Technical Support: The protocols provided are for reference purposes. Unsure if this reagent suits your experiment?

Need Industrial/Bulk Grade? [Request Custom Synthesis Quote](#)

BenchChem

Our mission is to be the trusted global source of essential and advanced chemicals, empowering scientists and researchers to drive progress in science and industry.

Contact

Address: 3281 E Guasti Rd
Ontario, CA 91761, United States
Phone: (601) 213-4426
Email: info@benchchem.com

[Contact our Ph.D. Support Team for a compatibility check](#)