

Technical Support Center: Minimizing Variability in PF9 Tetrasodium Salt Experiments

Author: BenchChem Technical Support Team. **Date:** May 2026

Compound of Interest

Compound Name: PF9 tetrasodium salt

CAS No.: 851265-78-6

Cat. No.: B1139097

[Get Quote](#)

Welcome to the technical support center for **PF9 tetrasodium salt**, a potent and selective agonist of the G-protein coupled receptor 17 (GPR17). This guide is designed for researchers, scientists, and drug development professionals to provide in-depth technical guidance and troubleshooting advice to ensure the consistency and reliability of your experimental results. Variability in in-vitro experiments can obscure genuine biological effects; this resource aims to empower you with the knowledge to minimize such variability by understanding the causality behind experimental choices.

Section 1: Understanding PF9 Tetrasodium Salt and its Target, GPR17

FAQ 1.1: What is PF9 tetrasodium salt and why is it used in research?

PF9 tetrasodium salt, with the chemical formula $C_{18}H_{16}N_5Na_4O_{13}P_3$, is a potent agonist for the GPR17 receptor, exhibiting a high affinity with an EC_{50} of 36 pM.[1] Its primary application in research is to selectively activate GPR17 to study its downstream signaling pathways and physiological roles. GPR17 is a receptor of significant interest as it is implicated in various

biological processes, most notably in the regulation of oligodendrocyte differentiation and myelination in the central nervous system.[2]

FAQ 1.2: What is the signaling mechanism of GPR17 upon activation by PF9 tetrasodium salt?

GPR17 is a dual-ligand receptor, responding to both purinergic ligands and cysteinyl leukotrienes. Upon agonist binding, such as with **PF9 tetrasodium salt**, GPR17 primarily couples to the G α i/o subunit of the heterotrimeric G-protein complex.[3] This activation leads to the inhibition of adenylyl cyclase, resulting in a decrease in intracellular cyclic adenosine monophosphate (cAMP) levels.[4] In some cellular contexts, GPR17 can also couple to the G α q subunit, leading to the activation of phospholipase C and subsequent mobilization of intracellular calcium. Understanding this primary signaling pathway is crucial for designing appropriate functional readouts for your experiments.

GPR17 Signaling Pathway

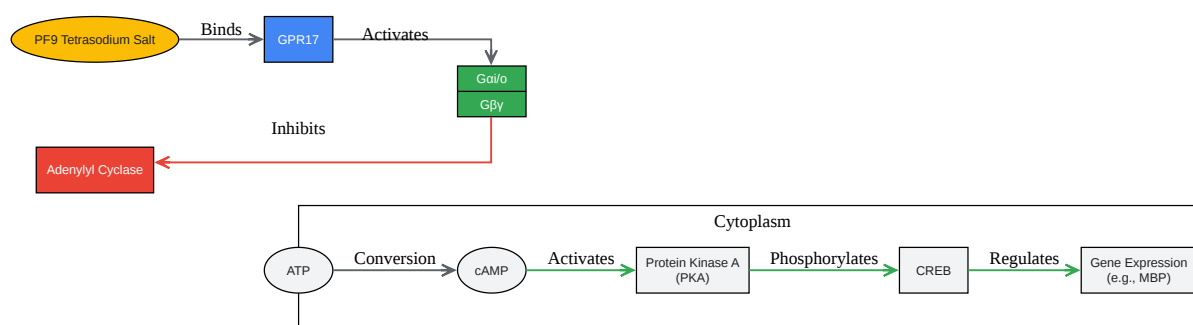

[Click to download full resolution via product page](#)

Caption: GPR17 activation by **PF9 tetrasodium salt** inhibits cAMP production.

Section 2: Reagent Handling and Storage - The First Line of Defense Against Variability

The stability and handling of **PF9 tetrasodium salt** are critical factors that can introduce significant variability. As an adenosine triphosphate (ATP) analog, its stability is influenced by factors such as pH, temperature, and the presence of enzymes.

FAQ 2.1: What are the optimal storage and handling conditions for PF9 tetrasodium salt?

- Long-term Storage: **PF9 tetrasodium salt** should be stored as a lyophilized powder at -20°C in a desiccated environment.[1] Protecting the powder from moisture is crucial, as it is hygroscopic.[5]
- Solution Preparation: Reconstitute the lyophilized powder in sterile, nuclease-free water or a suitable buffer immediately before use.[6] For a 10 mM stock solution, use the batch-specific molecular weight provided on the product's certificate of analysis for accurate calculations.[1]
- Short-term Storage of Solutions: Aqueous solutions of ATP analogs are stable for short periods. For short-term storage, solutions with a pH of 7.0–7.4 are stable for up to 72 hours at 4°C .[5]
- Long-term Storage of Solutions: For longer-term storage, it is recommended to aliquot the reconstituted solution into single-use volumes and store them at -80°C .[5] Crucially, avoid repeated freeze-thaw cycles, as this can lead to degradation of the triphosphate chain.

FAQ 2.2: My PF9 tetrasodium salt solution has been stored for a while. How can I be sure it's still active?

Variability in results can often be traced back to reagent degradation. Since PF9 is an ATP analog, it is susceptible to hydrolysis to its diphosphate and monophosphate forms, which will have reduced or no activity at the GPR17 receptor.

Best Practice: Always prepare fresh working solutions from a frozen stock for each experiment. If you suspect your stock solution has degraded, it is best to discard it and prepare a fresh stock from the lyophilized powder. For highly sensitive or long-term studies, consider

performing a dose-response curve with a new batch of PF9 to ensure its potency has not changed.

Parameter	Recommendation	Rationale
Storage Form	Lyophilized powder	Maximizes long-term stability.
Storage Temperature	-20°C (powder), -80°C (solution)	Minimizes chemical and enzymatic degradation.[5]
Solvent	Nuclease-free water or buffer (pH 7.0-7.4)	ATP analogs are stable at neutral pH.[7]
Freeze-Thaw Cycles	Avoid	Repeated cycling can cause degradation of the phosphate chain.[5]

Table 1: Recommended Storage and Handling of **PF9 Tetrasodium Salt**

Section 3: Experimental Design and Execution - Controlling for Confounding Factors

Careful experimental design and execution are paramount to minimizing variability. This section provides troubleshooting guidance for common assays involving **PF9 tetrasodium salt**.

FAQ 3.1: I'm not seeing a consistent decrease in cAMP levels in my GPR17-expressing cells after treatment with PF9. What could be the issue?

Inconsistent results in a cAMP assay can stem from several factors. Here is a systematic approach to troubleshooting:

Experimental Workflow for a cAMP Assay

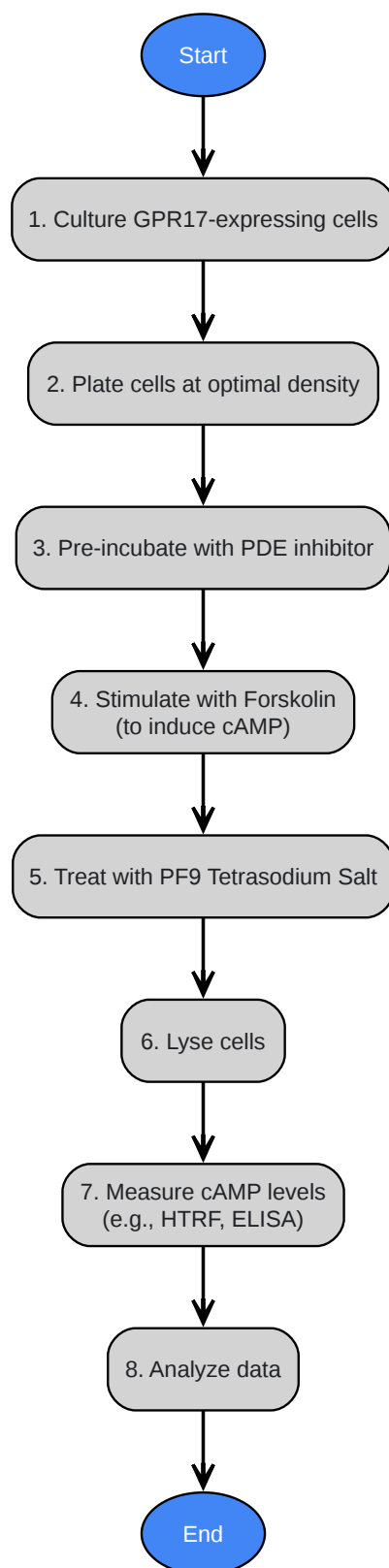

[Click to download full resolution via product page](#)

Caption: A typical workflow for measuring cAMP inhibition.

- **Cell Health and Passage Number:** Ensure your cells are healthy and within a consistent, low passage number range. High passage numbers can lead to phenotypic drift and altered receptor expression or signaling.
- **Phosphodiesterase (PDE) Activity:** Intracellular PDEs rapidly degrade cAMP. It is essential to include a PDE inhibitor, such as IBMX or rolipram, in your assay buffer to allow for the accumulation of cAMP.[8]
- **Forskolin Concentration:** Forskolin is commonly used to stimulate adenylyl cyclase and increase basal cAMP levels, making the inhibitory effect of GPR17 activation more pronounced. Optimize the forskolin concentration to achieve a robust but not saturating cAMP signal.
- **PF9 Concentration and Incubation Time:** Perform a dose-response curve to determine the optimal concentration of PF9 for your cell type. Also, optimize the incubation time; a time course experiment can reveal the point of maximal inhibition.
- **Off-Target Effects:** GPR17 shares homology with other P2Y and cysteinyl leukotriene (CysLT) receptors.[9] To confirm that the observed effect is GPR17-specific, consider using a GPR17 antagonist, such as cangrelor or montelukast, to block the effect of PF9.[9] Additionally, perform the experiment in a parental cell line that does not express GPR17 as a negative control.

FAQ 3.2: My oligodendrocyte differentiation assay is showing variable results with PF9 treatment. How can I improve consistency?

The role of GPR17 in oligodendrocyte differentiation is complex; sustained activation can inhibit the terminal maturation of oligodendrocytes.[10] Therefore, the timing and duration of PF9 treatment are critical.

Protocol: In-Vitro Oligodendrocyte Differentiation Assay

- **Cell Seeding:** Plate primary oligodendrocyte precursor cells (OPCs) or a suitable cell line (e.g., A1 cells) on a permissive substrate.[11]

- Proliferation Phase: Culture the cells in a proliferation medium containing growth factors such as PDGF and FGF to expand the OPC population.[10]
- Differentiation Induction: To induce differentiation, withdraw the growth factors from the culture medium.[11]
- PF9 Treatment: Introduce **PF9 tetrasodium salt** at the desired concentration at a specific time point during the differentiation process. The timing of addition is a critical variable to optimize.
- Assessment of Differentiation: After a defined period (e.g., 4-6 days), assess oligodendrocyte differentiation and maturation by immunocytochemistry for stage-specific markers such as O1, and myelin basic protein (MBP).[10]
- Quantification: Quantify the percentage of differentiated oligodendrocytes and analyze their morphology.

Troubleshooting Variability in Differentiation Assays:

- Initial Cell Population: Ensure a consistent and pure starting population of OPCs.
- Timing of Treatment: The developmental stage of the oligodendrocytes when they are exposed to PF9 will significantly impact the outcome. Experiment with adding PF9 at different days post-differentiation induction.
- Duration of Treatment: Continuous exposure to a potent agonist like PF9 may lead to receptor desensitization and internalization, altering the cellular response over time. Consider pulsed treatments versus continuous exposure.
- Readout Specificity: Use a panel of markers to assess different stages of oligodendrocyte differentiation to get a more complete picture of the treatment effect.

Parameter	Recommendation	Rationale
Cell Source	Primary OPCs or validated cell line	Ensures a relevant and consistent biological system. [11]
Differentiation Stimulus	Growth factor withdrawal	A standard method to induce oligodendrocyte differentiation. [11]
PF9 Treatment Timing	Optimize (e.g., day 0, 2, 4 post-induction)	GPR17's role is stage-dependent.[10]
Differentiation Markers	O1, MBP	Allows for the assessment of different stages of maturation. [10]

Table 2: Key Parameters for Oligodendrocyte Differentiation Assays

Section 4: Data Interpretation and Validation

FAQ 4.1: How do I ensure the effects I'm seeing are truly mediated by GPR17?

To ensure the specificity of your results, it is crucial to include proper controls in your experiments.

- **Pharmacological Inhibition:** Use a selective GPR17 antagonist to demonstrate that the effect of PF9 can be blocked.
- **Genetic Knockdown/Knockout:** If possible, use siRNA-mediated knockdown or cells from a GPR17 knockout animal to show that the effect of PF9 is absent in the absence of the receptor.
- **Parental Cell Line Control:** Compare the response of your GPR17-expressing cells to a parental cell line that lacks the receptor.

By implementing these rigorous controls, you can be confident that your observations are a direct result of GPR17 activation by **PF9 tetrasodium salt**.

References

- Fumagalli, M., et al. (2011).
- Wikipedia. (2024).
- Ciana, P., et al. (2006). Agonist-Induced Desensitization/Resensitization of Human G Protein-Coupled Receptor 17: A Functional Cross-Talk between Purinergic and Cysteinyl-Leukotriene Ligands. *Molecular Pharmacology*.
- Chen, Y., et al. (2014). The GPR17 Receptor—A Promising Goal for Therapy and a Potential Marker of the Neurodegenerative Process in Multiple Sclerosis.
- Hennen, S., et al. (2013). Decoding Signaling and Function of the Orphan G Protein-Coupled Receptor GPR17 with a Small-Molecule Agonist. *Science Signaling*.
- R&D Systems. **PF9 tetrasodium salt**.
- Sigma-Aldrich. (2023). Adenosine 5'-triphosphate disodium salt hydrate (A3377)
- Ciana, P., et al. (2006). The Recently Identified P2Y-Like Receptor GPR17 Is a Sensor of Brain Damage and a New Target for Brain Repair. *PLoS ONE*.
- Kandhavelu, M., et al. (2017). Identification of novel GPR17-agonists by structural bioinformatics and signaling activation. *International Journal of Biological Macromolecules*.
- Parker, T. L., et al. (2024).
- Viganò, F., et al. (2016). The Orphan G Protein-coupled Receptor GPR17 Negatively Regulates Oligodendrocyte Differentiation via Gai/o and Its Downstream Effector Molecules. *Journal of Biological Chemistry*.
- Stys, P. K. (2025). GPR17 structure and agonism with small molecules and oxysterols. *bioRxiv*.
- Parravicini, C., et al. (2020). Regulation and signaling of the GPR17 receptor in oligodendroglial cells. *Journal of Neuroscience Research*.
- Daniele, S., et al. (2022). Functional Heterodimerization between the G Protein-Coupled Receptor GPR17 and the Chemokine Receptors 2 and 4: New Evidence.
- BenchChem. (2025). GPR17 Agonist Experiments: Technical Support Center.
- van der Valk, M. A., et al. (1995). The MTT tetrazolium salt assay scrutinized: how to use this assay reliably to measure metabolic activity of cell cultures in vitro for the assessment of growth characteristics, IC50-values and cell survival. *European Journal of Clinical Chemistry and Clinical Biochemistry*.
- Lee, S., et al. (2012). A rapid and reproducible assay for modeling myelination by oligodendrocytes using engineered nanofibers.
- Salt Institute. (2014). *Salt Storage Handbook*.
- Windrem, M. S., et al. (2004). Differential generation of oligodendrocytes from human and rodent embryonic spinal cord neural precursors. *Developmental Neuroscience*.

- Baydy, A. L., et al. (2021). Cell of all trades: oligodendrocyte precursor cells in synaptic, vascular, and immune function. *Journal of Neuroscience*.
- BenchChem. (2025). Best practices for storing and handling ITPP sodium salt.
- NHDES. (2011). Salt Storage.

Need Custom Synthesis?

BenchChem offers custom synthesis for rare earth carbides and specific isotopic labeling.

Email: info@benchchem.com or [Request Quote Online](#).

Sources

- 1. Stabilization of the ADP/Metaphosphate Intermediate during ATP Hydrolysis in Pre-power Stroke Myosin: QUANTITATIVE ANATOMY OF AN ENZYME - PMC [[pmc.ncbi.nlm.nih.gov](https://pubmed.ncbi.nlm.nih.gov/)]
- 2. ATP Analogues for Structural Investigations: Case Studies of a DnaB Helicase and an ABC Transporter - PMC [[pmc.ncbi.nlm.nih.gov](https://pubmed.ncbi.nlm.nih.gov/)]
- 3. Repurposing HAMI3379 to Block GPR17 and Promote Rodent and Human Oligodendrocyte Differentiation - PMC [[pmc.ncbi.nlm.nih.gov](https://pubmed.ncbi.nlm.nih.gov/)]
- 4. drscw.org [drscw.org]
- 5. pdf.benchchem.com [pdf.benchchem.com]
- 6. sigmaaldrich.com [sigmaaldrich.com]
- 7. Adenosine triphosphate - Wikipedia [en.wikipedia.org]
- 8. biorxiv.org [biorxiv.org]
- 9. The Recently Identified P2Y-Like Receptor GPR17 Is a Sensor of Brain Damage and a New Target for Brain Repair - PMC [[pmc.ncbi.nlm.nih.gov](https://pubmed.ncbi.nlm.nih.gov/)]
- 10. Morphological Differentiation of Oligodendrocytes Requires Activation of Fyn Tyrosine Kinase - PMC [[pmc.ncbi.nlm.nih.gov](https://pubmed.ncbi.nlm.nih.gov/)]
- 11. Generation of High-Yield, Functional Oligodendrocytes from a c-myc Immortalized Neural Cell Line, Endowed with Staminal Properties - PMC [[pmc.ncbi.nlm.nih.gov](https://pubmed.ncbi.nlm.nih.gov/)]
- To cite this document: BenchChem. [Technical Support Center: Minimizing Variability in PF9 Tetrasodium Salt Experiments]. BenchChem, [2026]. [Online PDF]. Available at: [<https://www.benchchem.com/product/b1139097/docs#technical-support-center-minimizing-variability-in-pf9-tetrasodium-salt-experiments>]

Disclaimer & Data Validity:

The information provided in this document is for Research Use Only (RUO) and is strictly not intended for diagnostic or therapeutic procedures. While BenchChem strives to provide accurate protocols, we make no warranties, express or implied, regarding the fitness of this product for every specific experimental setup.

Technical Support: The protocols provided are for reference purposes. Unsure if this reagent suits your experiment?

Need Industrial/Bulk Grade? [Request Custom Synthesis Quote](#)

BenchChem

Our mission is to be the trusted global source of essential and advanced chemicals, empowering scientists and researchers to drive progress in science and industry.

Contact

Address: 3281 E Guasti Rd
Ontario, CA 91761, United States
Phone: (601) 213-4426
Email: info@benchchem.com

[Contact our Ph.D. Support Team for a compatibility check](#)