

Technical Support Center: Bttaa Ligand Synthesis

Author: BenchChem Technical Support Team. **Date:** April 2026

Compound of Interest

Compound Name: *Bttaa*
Cat. No.: *B1139149*

[Get Quote](#)

This technical support center provides researchers, scientists, and drug development professionals with a comprehensive guide to improving the yield of **Bttaa** (2-(4-((bis((1-(tert-butyl)-1H-1,2,3-triazol-4-yl)methyl)amino)methyl)-1H-1,2,3-triazol-1-yl)acetic acid) ligand synthesis. The information is presented in a question-and-answer format to directly address specific issues that may be encountered during the experimental process.

Frequently Asked Questions (FAQs)

Q1: What is the general strategy for synthesizing the **Bttaa** ligand?

A1: The synthesis of **Bttaa** is a multi-step process that can be broken down into three main stages:

- Synthesis of the core amine: This involves the double propargylation of an amine precursor to create a dipropargyl amine.
- Double CuAAC "Click" Reaction: The dipropargyl amine is then reacted with tert-butyl azide in a copper(I)-catalyzed azide-alkyne cycloaddition (CuAAC) to form the bis(tert-butyl-triazolylmethyl)amine core structure.

- Functionalization: Finally, the acetic acid moiety is introduced by reacting the core structure with an appropriate reagent, such as bromoacetic acid.

Q2: Why is the choice of copper source and ligand important in the CuAAC step?

A2: The copper(I) catalyst is essential for the CuAAC reaction. However, Cu(I) is prone to oxidation to the inactive Cu(II) state. A stabilizing ligand, in this case, a portion of the synthesized product or a related tris(triazolylmethyl)amine ligand like THPTA, can be used to protect the Cu(I) from oxidation and improve the reaction rate and overall yield. The choice of copper salt (e.g., CuSO₄ with a reducing agent, or a Cu(I) salt like CuI) can also impact reaction efficiency.

Q3: What are the critical parameters to control for a high-yield synthesis?

A3: Key parameters to optimize include:

- Stoichiometry of reactants: Precise control over the molar ratios of the amine, propargylating agent, tert-butyl azide, and acetic acid derivative is crucial.
- Reaction temperature: Each step has an optimal temperature range for achieving a good reaction rate while minimizing side reactions.
- Solvent choice: The solvent should be appropriate for the solubility of all reactants and reagents and should not interfere with the reaction.
- Catalyst loading and purity: The amount and quality of the copper catalyst and any additives (like a reducing agent) directly impact the efficiency of the CuAAC step.
- Purification methods: Effective purification at each step is necessary to remove byproducts and unreacted starting materials that could interfere with subsequent reactions.

Experimental Protocol: Synthesis of Bttaa Ligand

This protocol describes a plausible three-step synthesis for the **Bttaa** ligand.

Step 1: Synthesis of N,N-bis(prop-2-yn-1-yl)amine (Dipropargylamine)

- To a solution of propargylamine (1.0 eq) in a suitable solvent such as acetonitrile, add potassium carbonate (2.5 eq) and propargyl bromide (1.1 eq).
- Stir the reaction mixture vigorously at room temperature for 24-48 hours.
- Monitor the reaction progress by thin-layer chromatography (TLC).
- Upon completion, filter the mixture to remove the potassium carbonate.
- Concentrate the filtrate under reduced pressure to obtain the crude dipropargylamine.
- Purify the crude product by vacuum distillation or column chromatography.

Step 2: Synthesis of N,N-bis((1-(tert-butyl)-1H-1,2,3-triazol-4-yl)methyl)amine

- Dissolve dipropargylamine (1.0 eq) and tert-butyl azide (2.2 eq) in a mixture of t-butanol and water (1:1).
- Add sodium ascorbate (0.2 eq) to the solution.
- In a separate vial, prepare the copper catalyst by dissolving copper(II) sulfate pentahydrate (0.1 eq) in water.
- Add the copper sulfate solution to the reaction mixture and stir at room temperature for 12-24 hours.
- Monitor the reaction by TLC or LC-MS.
- Upon completion, the product may precipitate from the reaction mixture. If so, it can be collected by filtration. Otherwise, extract the product with a suitable organic solvent (e.g., ethyl acetate).
- Wash the organic layer with brine, dry over sodium sulfate, and concentrate under reduced pressure.
- Purify the crude product by column chromatography.

Step 3: Synthesis of **Bttaa** Ligand

- Dissolve the N,N-bis((1-(tert-butyl)-1H-1,2,3-triazol-4-yl)methyl)amine (1.0 eq) from Step 2 in a polar aprotic solvent like DMF.
- Add a base such as sodium hydride (1.2 eq) carefully at 0 °C.
- Stir the mixture for 30 minutes, then add ethyl bromoacetate (1.1 eq).
- Allow the reaction to warm to room temperature and stir for 12-16 hours.
- Quench the reaction by the slow addition of water.
- Extract the ethyl ester intermediate with an organic solvent.
- To hydrolyze the ester, dissolve the crude product in a mixture of THF and water, and add lithium hydroxide (2.0 eq).
- Stir at room temperature for 4-6 hours until the hydrolysis is complete (monitored by TLC).
- Acidify the mixture with dilute HCl to pH 3-4, and extract the **Bttaa** product with a suitable organic solvent.
- Dry the organic layer, concentrate, and purify the final product by recrystallization or column chromatography.

Troubleshooting Guide

Problem	Possible Cause(s)	Recommended Solution(s)
Step 1: Low yield of dipropargylamine	- Incomplete reaction. - Over-alkylation to form the quaternary ammonium salt.	- Increase reaction time. - Use a milder base or lower the reaction temperature. - Use a slight excess of propargylamine relative to propargyl bromide.
Step 2: Low yield in CuAAC reaction	- Inactive copper catalyst (oxidized to Cu(II)). - Insufficient reducing agent. - Steric hindrance from the tert-butyl group. - Alkyne homocoupling (Glaser coupling).	- Ensure the sodium ascorbate solution is freshly prepared. - Degas the solvent to remove oxygen. - Increase the amount of sodium ascorbate. - Consider adding a Cu(I)-stabilizing ligand (e.g., THPTA) to the reaction. - Run the reaction under an inert atmosphere (N ₂ or Ar).
Step 2: Difficulty in product purification	- Presence of copper catalyst in the final product. - Similar polarity of starting material and product.	- Wash the crude product with an aqueous solution of a chelating agent like EDTA to remove copper. - Optimize the mobile phase for column chromatography to achieve better separation.
Step 3: Incomplete alkylation with ethyl bromoacetate	- Base is not strong enough to deprotonate the amine. - Steric hindrance around the secondary amine.	- Use a stronger base like sodium hydride. - Increase the reaction temperature, but monitor for decomposition. - Increase the reaction time.
Step 3: Low yield of final Bttaa product	- Incomplete hydrolysis of the ethyl ester. - Difficulty in extracting the final product due to its polarity.	- Increase the hydrolysis time or use a stronger base like NaOH. - After acidification, saturate the aqueous layer with NaCl before extraction to improve partitioning into the

organic layer. - Use a more polar solvent for extraction, such as a mixture of dichloromethane and isopropanol.

Table 1: Reaction Parameters for Optimization in CuAAC (Step 2)

Parameter	Typical Range	Notes
Copper(II) Sulfate (mol%)	1 - 10	Higher loading can increase rate but complicates removal.
Sodium Ascorbate (mol%)	10 - 50	Should be in excess of the copper catalyst.
Solvent System	t-BuOH/H ₂ O, DMSO/H ₂ O, THF/H ₂ O	Co-solvents are often necessary to dissolve all reactants.
Temperature (°C)	20 - 40	Room temperature is usually sufficient.
Reaction Time (h)	12 - 48	Monitor by TLC or LC-MS for completion.

Visualizations

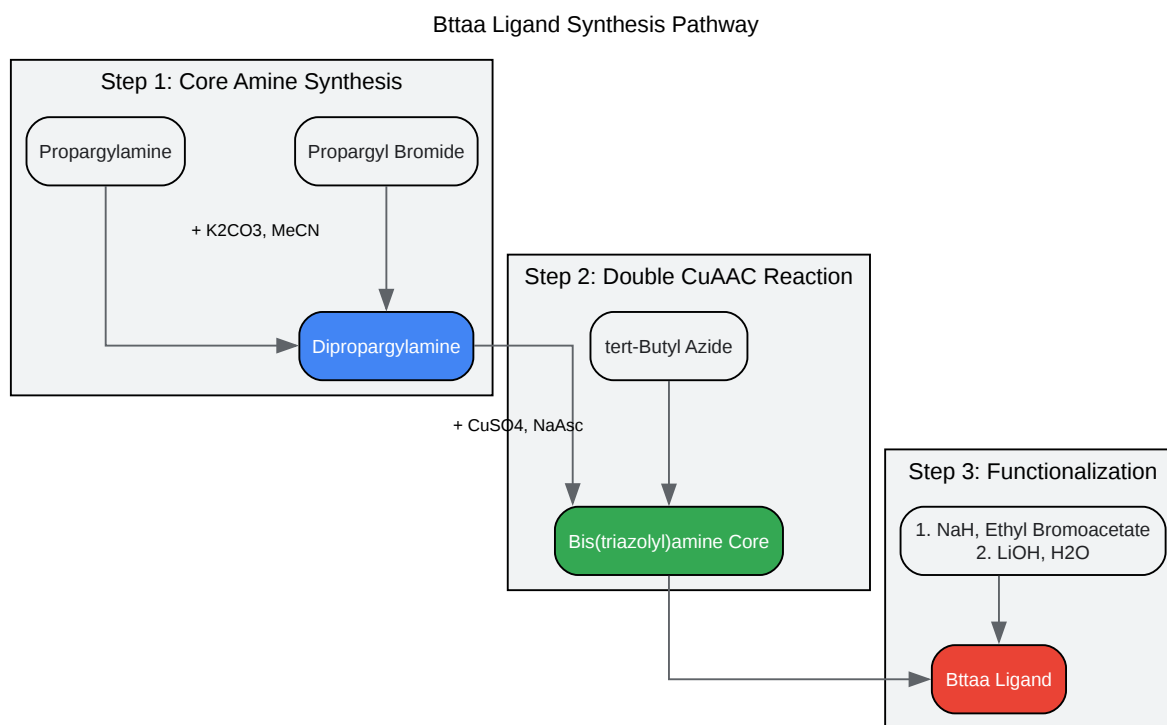

[Click to download full resolution via product page](#)

Caption: A diagram illustrating the three main stages of **Bttaa** ligand synthesis.

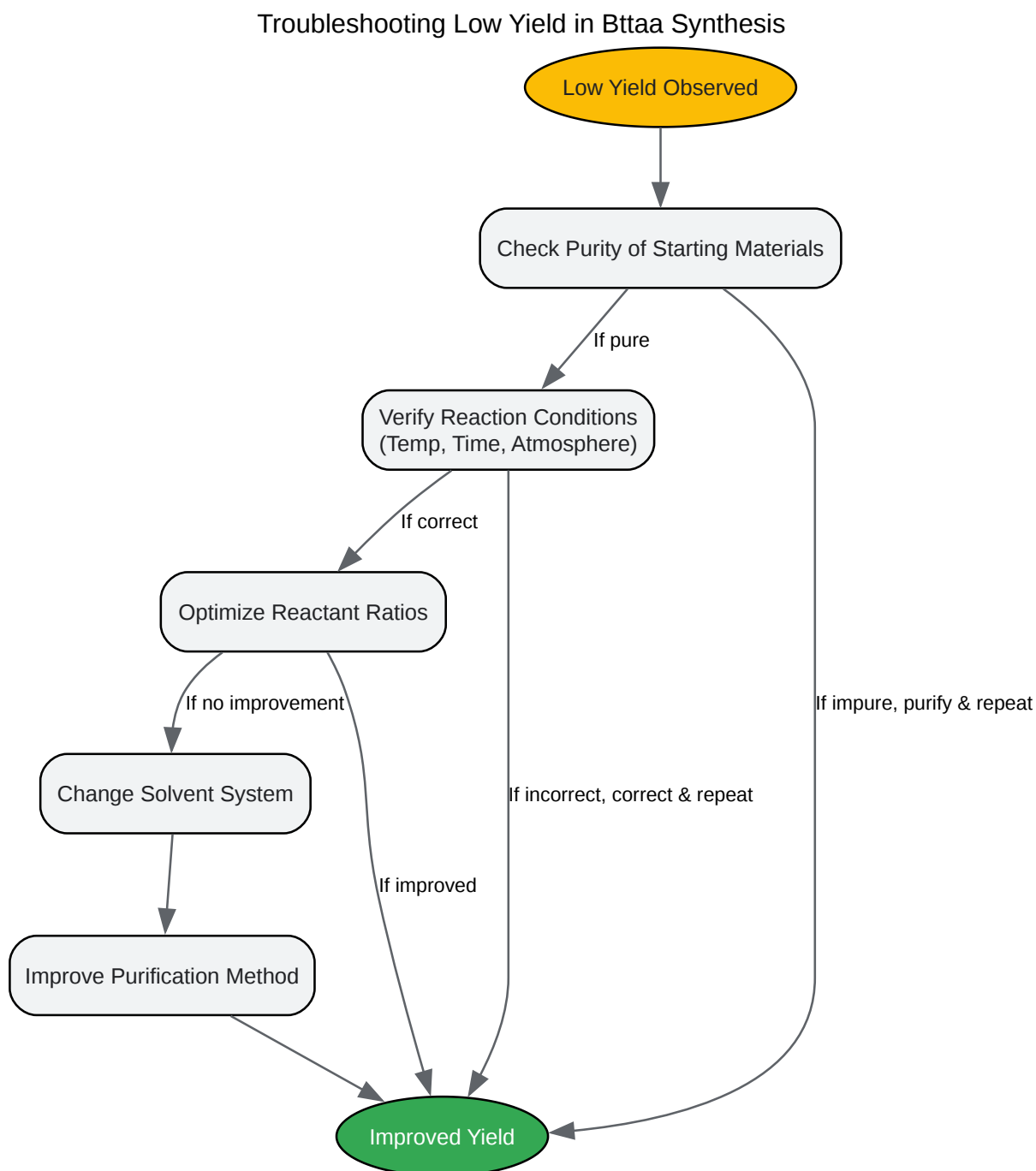

[Click to download full resolution via product page](#)

Caption: A logical workflow for troubleshooting low yield issues in the synthesis of **Bttaa**.

- To cite this document: [BenchChem. \[Technical Support Center: Bttaa Ligand Synthesis\]. BenchChem, \[2026\]. \[Online PDF\]. Available at:](#)

[\[https://www.benchchem.com/product/b1139149/docs#technical-support-center-bttaa-ligand-synthesis\]](https://www.benchchem.com/product/b1139149/docs#technical-support-center-bttaa-ligand-synthesis)

Disclaimer & Data Validity:

The information provided in this document is for Research Use Only (RUO) and is strictly not intended for diagnostic or therapeutic procedures. While BenchChem strives to provide accurate protocols, we make no warranties, express or implied, regarding the fitness of this product for every specific experimental setup.

Technical Support: The protocols provided are for reference purposes. Unsure if this reagent suits your experiment?

Need Industrial/Bulk Grade? [Request Custom Synthesis Quote](#)

BenchChem

Our mission is to be the trusted global source of essential and advanced chemicals, empowering scientists and researchers to drive progress in science and industry.

Contact

Address: 3281 E Guasti Rd
Ontario, CA 91761, United States
Phone: (601) 213-4426
Email: info@benchchem.com

[Contact our Ph.D. Support Team for a compatibility check](#)