

# Pembrolizumab: A Comparative Analysis of Monotherapy and Combination Therapies in Oncology

**Author:** BenchChem Technical Support Team. **Date:** December 2025

## Compound of Interest

Compound Name: *Pembrolizumab*

Cat. No.: *B1139204*

[Get Quote](#)

For Researchers, Scientists, and Drug Development Professionals

**Pembrolizumab**, an immune checkpoint inhibitor targeting the programmed cell death-1 (PD-1) receptor, has revolutionized the treatment landscape for a multitude of malignancies.[1][2] Its mechanism of action, which involves blocking the interaction between PD-1 on T-cells and its ligands (PD-L1 and PD-L2) on tumor cells, effectively unleashes the body's own immune system to combat cancer.[3] While **pembrolizumab** monotherapy has demonstrated significant efficacy, the quest for enhanced anti-tumor activity and strategies to overcome resistance has led to extensive investigation into its use in combination with other therapeutic agents.

This guide provides a comparative analysis of **pembrolizumab** monotherapy versus combination therapies across three key cancer types: Non-Small Cell Lung Cancer (NSCLC), Melanoma, and Renal Cell Carcinoma (RCC). The objective is to present a clear, data-driven comparison of treatment efficacy and safety, supported by experimental data from pivotal clinical trials.

## Mechanism of Action: Releasing the Brakes on T-Cells

**Pembrolizumab's** therapeutic effect is rooted in its ability to restore T-cell-mediated anti-tumor immunity.[2] In the tumor microenvironment, cancer cells can express PD-L1 and PD-L2, which bind to the PD-1 receptor on activated T-cells.[3] This interaction triggers an inhibitory signal,

leading to T-cell "exhaustion," a state of dysfunction characterized by reduced proliferation and cytokine production.[2] By binding to the PD-1 receptor, **pembrolizumab** blocks this interaction, thereby "releasing the brakes" on T-cells and enabling them to recognize and eliminate cancer cells.[1][2]

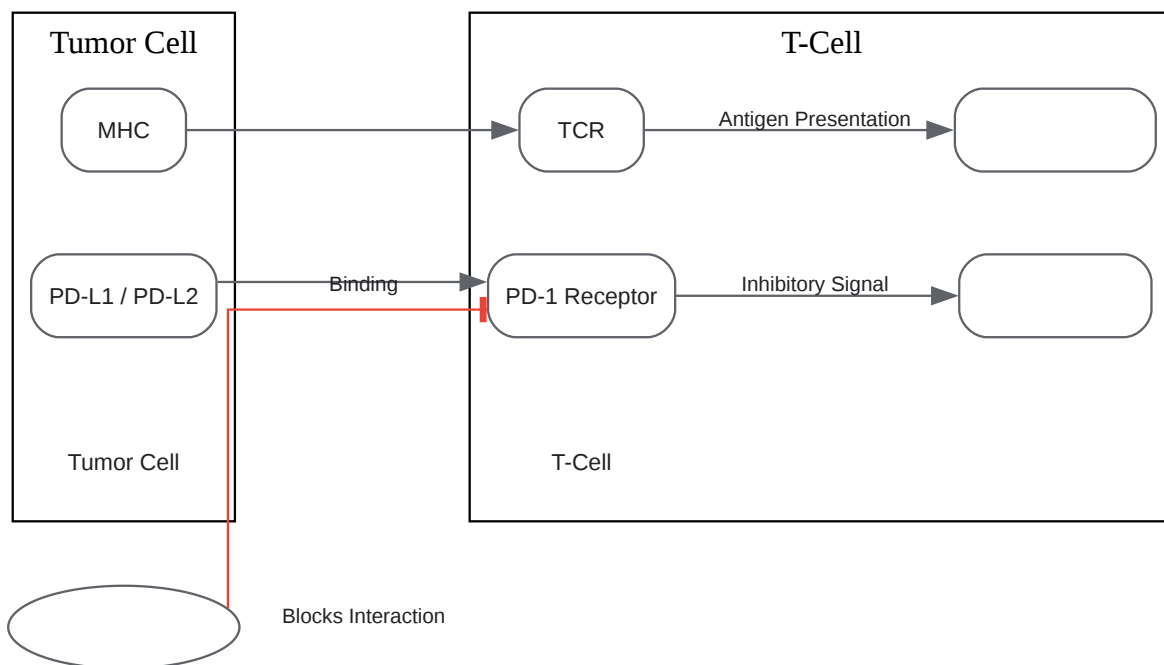

[Click to download full resolution via product page](#)

### Pembrolizumab's Mechanism of Action

## Non-Small Cell Lung Cancer (NSCLC)

In the first-line treatment of metastatic NSCLC without EGFR or ALK genomic tumor aberrations, **pembrolizumab** in combination with chemotherapy has demonstrated superior efficacy compared to chemotherapy alone. The pivotal KEYNOTE-189 (for non-squamous NSCLC) and KEYNOTE-407 (for squamous NSCLC) trials established this combination as a standard of care.

## Quantitative Data Summary: Pembrolizumab in First-Line Metastatic NSCLC

Trial (Histology)	Treatment Arm	N	Median Overall Survival (OS)	Median Progression-Free Survival (PFS)	Objective Response Rate (ORR)
KEYNOTE-189 (Non-Squamous)	Pembrolizumab + Pemetrexed/Platinum	410	22.0 months	9.0 months	48.0%
	Placebo + Pemetrexed/Platinum	206	10.7 months	4.9 months	19.0%
KEYNOTE-407 (Squamous)	Pembrolizumab + Carboplatin/Paclitaxel or Nab-Paclitaxel	278	17.1 months	8.0 months	62.6%
	Placebo + Carboplatin/Paclitaxel or Nab-Paclitaxel	281	11.6 months	5.1 months	38.8%

Data from KEYNOTE-189 and KEYNOTE-407 final analyses.

## Experimental Protocol: KEYNOTE-189

The KEYNOTE-189 trial was a phase 3, randomized, double-blind, placebo-controlled study.<sup>[4]</sup>

- Patient Population:** Patients with previously untreated metastatic non-squamous NSCLC without sensitizing EGFR or ALK mutations.<sup>[5]</sup> Key inclusion criteria included no prior systemic treatment for metastatic disease and an ECOG performance status of 0 or 1.<sup>[6]</sup> Exclusion criteria included active autoimmune disease requiring systemic therapy and known active central nervous system metastases.<sup>[5]</sup>

- Treatment Arms:
  - **Pembrolizumab** (200 mg intravenously every 3 weeks) in combination with pemetrexed and a platinum-based chemotherapy (cisplatin or carboplatin) for 4 cycles, followed by maintenance **pembrolizumab** and pemetrexed.
  - Placebo in combination with pemetrexed and a platinum-based chemotherapy for 4 cycles, followed by maintenance placebo and pemetrexed.
- Primary Endpoints: Overall Survival (OS) and Progression-Free Survival (PFS).[4]

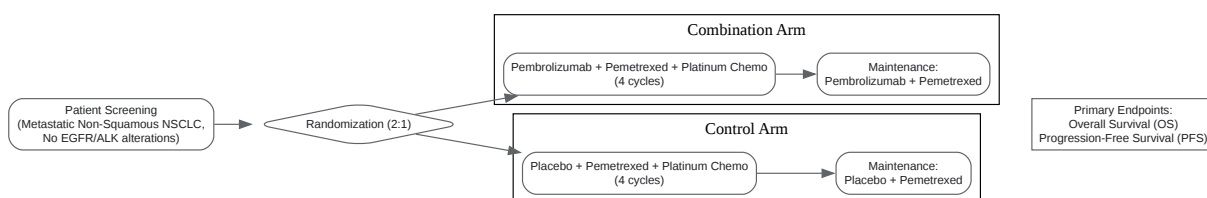

[Click to download full resolution via product page](#)

### KEYNOTE-189 Experimental Workflow

## Melanoma

For patients with advanced melanoma, **pembrolizumab** monotherapy has demonstrated a significant survival advantage over the anti-CTLA-4 antibody, ipilimumab. The KEYNOTE-006 trial established **pembrolizumab** as a standard of care in this setting.[7][8] Combination strategies are also being explored to further improve outcomes.

## Quantitative Data Summary: Pembrolizumab in Advanced Melanoma

Trial	Treatment Arm	N	Median Overall Survival (OS)	Median Progression-Free Survival (PFS)	Objective Response Rate (ORR)	7-Year OS Rate
KEYNOTE-006	Pembrolizumab	556	32.7 months	9.4 months	36-37%	37.8%
	Ipilimumab	278	15.9 months	3.8 months	13%	25.3%

Data from the 7-year follow-up of the KEYNOTE-006 trial.[\[8\]](#)[\[9\]](#)

## Experimental Protocol: KEYNOTE-006

The KEYNOTE-006 trial was a phase 3, randomized, open-label study.

- Patient Population: Patients with unresectable stage III or IV melanoma who had received up to one prior systemic therapy (excluding anti-CTLA-4, PD-1, or PD-L1 agents).
- Treatment Arms:
  - **Pembrolizumab** 10 mg/kg every 2 weeks.
  - **Pembrolizumab** 10 mg/kg every 3 weeks.
  - Ipilimumab 3 mg/kg every 3 weeks for four doses.[\[8\]](#)
- Primary Endpoints: Overall Survival (OS) and Progression-Free Survival (PFS).

## Renal Cell Carcinoma (RCC)

In advanced clear cell RCC, the combination of **pembrolizumab** with the tyrosine kinase inhibitor (TKI) axitinib has shown superior efficacy compared to sunitinib monotherapy. The KEYNOTE-426 trial demonstrated significant improvements in survival and response rates for the combination therapy.[\[10\]](#) Another immunotherapy combination, nivolumab plus ipilimumab,

has also proven to be an effective first-line treatment for intermediate- and poor-risk advanced RCC, as shown in the CheckMate 214 trial.[\[11\]](#)[\[12\]](#)

## Quantitative Data Summary: Pembrolizumab Combination in Advanced RCC

Trial	Treatment Arm	N	Median Overall Survival (OS)	Median Progression-Free Survival (PFS)	Objective Response Rate (ORR)
KEYNOTE-426	Pembrolizumab + Axitinib	432	47.2 months	15.7 months	60.6%
Sunitinib		429	40.8 months	11.1 months	39.6%
CheckMate 214 (Intermediate/Poor Risk)	Nivolumab + Ipilimumab	425	48.1 months	11.6 months	42%
Sunitinib		422	26.6 months	8.3 months	27%

Data from the final analysis of KEYNOTE-426 and long-term follow-up of CheckMate 214.[\[13\]](#)[\[14\]](#)[\[15\]](#)

## Experimental Protocol: KEYNOTE-426

The KEYNOTE-426 trial was a phase 3, randomized, open-label study.[\[10\]](#)

- Patient Population: Patients with previously untreated, advanced or metastatic clear cell RCC.
- Treatment Arms:
  - **Pembrolizumab** (200 mg intravenously every 3 weeks) plus axitinib (5 mg orally twice daily).

- Sunitinib (50 mg orally once daily for 4 weeks on, 2 weeks off).
- Primary Endpoints: Overall Survival (OS) and Progression-Free Survival (PFS).[10]

## Safety and Tolerability: A Comparative Overview

While combination therapies often lead to improved efficacy, they can also be associated with a higher incidence of adverse events. Careful monitoring and management of treatment-related toxicities are crucial.

### Selected Grade 3-5 Treatment-Related Adverse Events (%)

Adverse Event	Pembrolizuma b + Chemo (NSCLC - KEYNOTE-189)	Pembrolizuma b Monotherapy (Melanoma - KEYNOTE-006)	Pembrolizuma b + Axitinib (RCC - KEYNOTE-426)	Nivolumab + Ipilimumab (RCC - CheckMate 214)
Any Grade 3-5	67.2	14.0	62.9	46.0
Pneumonitis	2.7	1.5	3.0	1.0
Colitis	2.0	1.1	1.4	4.0
Hepatitis	2.5	0.7	7.0	4.0
Hypothyroidism	0.2	0.4	0.2	0.0
Hyperthyroidism	0.5	0.4	0.7	1.0

Data compiled from respective clinical trial publications. Note that direct cross-trial comparisons should be made with caution due to differences in study populations and methodologies.

## Conclusion

The evidence from large-scale clinical trials overwhelmingly supports the benefit of **pembrolizumab**, both as a monotherapy and as a component of combination regimens, across a range of advanced cancers. For first-line treatment of metastatic NSCLC and advanced RCC, combination strategies have demonstrated superior efficacy over monotherapy or older

standards of care. In advanced melanoma, **pembrolizumab** monotherapy has proven to be a highly effective treatment with a favorable long-term survival benefit.

The choice between **pembrolizumab** monotherapy and combination therapy is dependent on several factors, including cancer type, histological subtype, biomarker status (such as PD-L1 expression), and patient-specific characteristics. The increased efficacy of combination therapies must be weighed against the potential for increased toxicity. Ongoing research continues to explore novel combinations and biomarkers to further optimize patient outcomes and personalize cancer immunotherapy.

### Need Custom Synthesis?

BenchChem offers custom synthesis for rare earth carbides and specific isotopic labeling.

Email: [info@benchchem.com](mailto:info@benchchem.com) or [Request Quote Online](#).

## References

- 1. What is the mechanism of action of Pembrolizumab? [synapse.patsnap.com]
- 2. benchchem.com [benchchem.com]
- 3. Mechanism of Action of KEYTRUDA® (pembrolizumab) | Health Care Professionals [keytrudahcp.com]
- 4. Clinical insights: five-year follow-up of KEYNOTE-189 trial outcomes and more - PMC [pmc.ncbi.nlm.nih.gov]
- 5. ClinicalTrials.gov [clinicaltrials.gov]
- 6. Pembrolizumab Plus Chemotherapy in Newly Diagnosed NSCLC - The ASCO Post [ascopost.com]
- 7. Pembrolizumab versus ipilimumab for advanced melanoma: 10-year follow-up of the phase III KEYNOTE-006 study - PubMed [pubmed.ncbi.nlm.nih.gov]
- 8. Long-Term Survival Outcomes With Pembrolizumab vs Ipilimumab in Advanced Melanoma 7-Year Follow-up of KEYNOTE-006 - The ASCO Post [ascopost.com]
- 9. ascopubs.org [ascopubs.org]
- 10. Pembrolizumab plus axitinib versus sunitinib as first-line therapy for advanced renal cell carcinoma (RCC): Updated analysis of KEYNOTE-426 - UROONCO Kidney Cancer [kidney.uroonco.uroweb.org]



- 11. Nivolumab plus Ipilimumab versus Sunitinib in Advanced Renal-Cell Carcinoma - PubMed [pubmed.ncbi.nlm.nih.gov]
- 12. urotoday.com [urotoday.com]
- 13. urologytimes.com [urologytimes.com]
- 14. Nivolumab plus ipilimumab versus sunitinib for first-line treatment of advanced renal cell carcinoma: extended 8-year follow-up results of efficacy and safety from the phase III CheckMate 214 trial - PubMed [pubmed.ncbi.nlm.nih.gov]
- 15. cancernetwork.com [cancernetwork.com]
- To cite this document: BenchChem. [Pembrolizumab: A Comparative Analysis of Monotherapy and Combination Therapies in Oncology]. BenchChem, [2025]. [Online PDF]. Available at: [https://www.benchchem.com/product/b1139204#comparative-analysis-of-pembrolizumab-monotherapy-versus-combination-therapy]

---

#### Disclaimer & Data Validity:

The information provided in this document is for Research Use Only (RUO) and is strictly not intended for diagnostic or therapeutic procedures. While BenchChem strives to provide accurate protocols, we make no warranties, express or implied, regarding the fitness of this product for every specific experimental setup.

**Technical Support:** The protocols provided are for reference purposes. Unsure if this reagent suits your experiment? [[Contact our Ph.D. Support Team for a compatibility check](#)]

**Need Industrial/Bulk Grade?** [Request Custom Synthesis Quote](#)

## BenchChem

Our mission is to be the trusted global source of essential and advanced chemicals, empowering scientists and researchers to drive progress in science and industry.

#### Contact

Address: 3281 E Guasti Rd  
Ontario, CA 91761, United States  
Phone: (601) 213-4426  
Email: [info@benchchem.com](mailto:info@benchchem.com)