

Definitive Guide to PSB 11 Hydrochloride: Cross-Reactivity & A3AR Selectivity

Author: BenchChem Technical Support Team. **Date:** May 2026

Compound of Interest

Compound Name: PSB 11 hydrochloride

CAS No.: 453591-58-7

Cat. No.: B1139462

[Get Quote](#)

Executive Summary

PSB 11 hydrochloride (also known as PSB-11) is a high-affinity, selective antagonist for the human A3 adenosine receptor (hA3AR).[1][2] Its defining characteristic—and its primary pitfall for unwary researchers—is its extreme species selectivity. While it exhibits single-digit nanomolar affinity (

nM) for human A3 receptors, it is effectively inert at rat and mouse A3 receptors.

This guide provides a rigorous comparative analysis of PSB 11 against industry-standard alternatives (MRS 1220, MRS 1523), detailing cross-reactivity profiles and establishing a self-validating experimental framework for its use in drug discovery.

Compound Profile: PSB 11 Hydrochloride[1][3]

- Chemical Name: (R)-8-ethyl-4-methyl-2-phenyl-7,8-dihydro-3H-imidazo[2,1-i]purin-5(4H)-one hydrochloride[3]
- Primary Target: Human Adenosine A3 Receptor (hA3AR)

- Mechanism of Action: Competitive Antagonist / Inverse Agonist
- Key Utility: High-affinity radioligand (PSB-11) for labeling hA3AR due to low non-specific binding.[2]

Mechanistic Insight

Unlike non-selective xanthines (e.g., caffeine, theophylline), PSB 11 utilizes a specific imidazo-purinone scaffold that locks into the orthosteric site of the human A3 receptor. However, the orthosteric binding pocket of the A3 receptor diverges significantly between primates and rodents. PSB 11 relies on specific residues present in the human receptor that are absent or modified in the rodent homologs, rendering it ineffective for in vivo rodent models.

Comparative Analysis: Selectivity & Cross-Reactivity[4]

The following data contrasts PSB 11 with other common A3 antagonists. Note the "Species Gap" highlighted in the A3 (Rat/Mouse) column.

Table 1: Affinity Profile (in nM)[5][6]

Compound	hA3 (Human)	r/m A3 (Rodent)	hA1	hA2A	hA2B	Selectivity Profile
PSB 11	2.3	> 10,000 (Inactive)	> 10,000	> 10,000	> 10,000	Highly Selective (Human Only)
MRS 1220	0.65	> 1,000 (Weak)	> 1,000	> 1,000	189	Selective (Human Preferred)
MRS 1523	19	113 (Active)	15,600	2,100	> 1,000	Cross-Species Active
CGS 15943	14	N/A	3.5	1.2	5.0	Non-Selective (Pan-Antagonist)

Data compiled from Müller et al. and standard medicinal chemistry literature.

Selectivity Visualization

The following diagram illustrates the decision logic for selecting an A3 antagonist based on the model system, preventing false negatives in rodent studies.

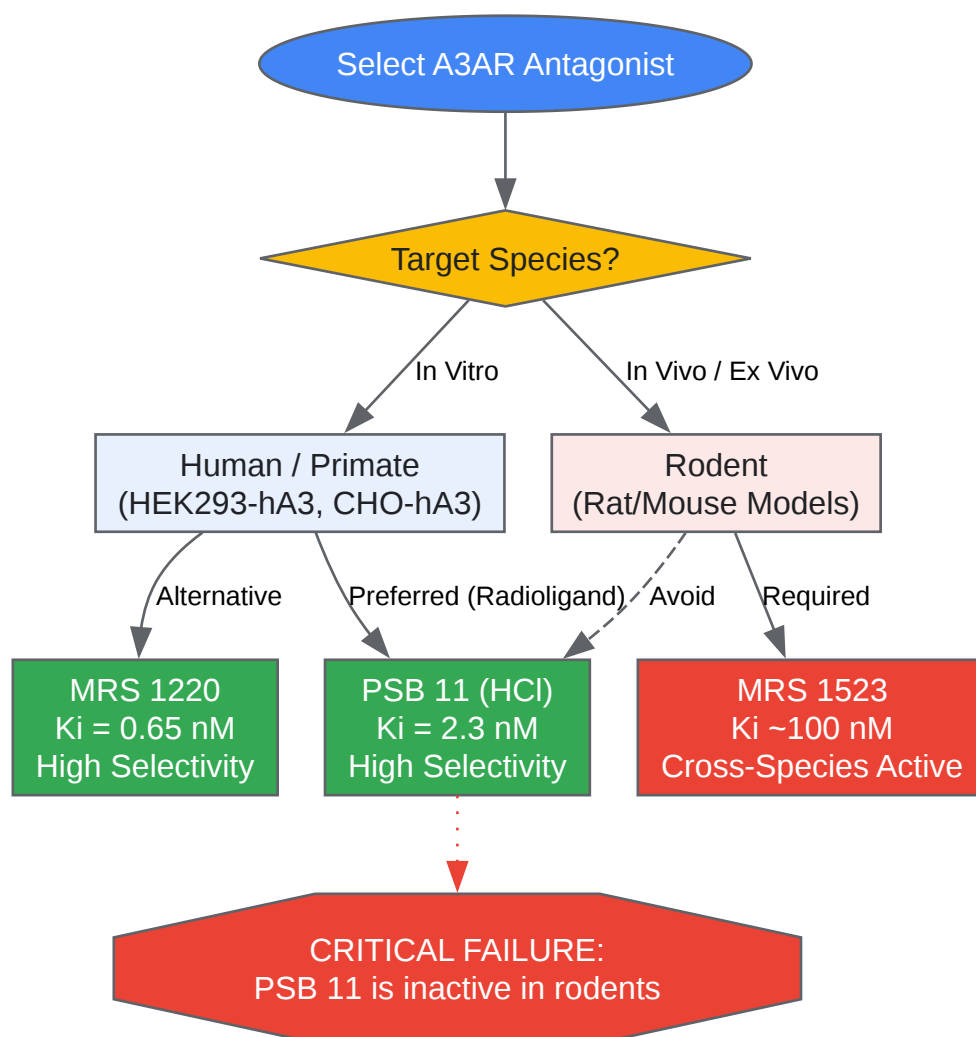

[Click to download full resolution via product page](#)

Figure 1: Decision tree for A3 Adenosine Receptor Antagonist selection. Note the critical divergence for rodent models.

Experimental Protocol: Self-Validating Radioligand Binding

Because PSB 11 is often used as a tritiated radioligand (

PSB-11), this protocol describes how to use it to validate other compounds or characterize receptor expression. If using non-labeled PSB 11 as a competitor, invert the logic (use a reference ligand like

AB-MECA).

Principle

The assay validates specific binding by defining "Total Binding" (Radioligand only) versus "Non-Specific Binding" (Radioligand + Excess Cold Competitor). A successful assay must show a Signal-to-Noise ratio

Materials

- Membrane Prep: CHO or HEK293 cells stably expressing human A3AR (do not use rodent lines).

- Radioligand:

PSB-11 (Specific Activity ~50-80 Ci/mmol).

- Displacer (Non-Specific Definer): 10

M R-PIA or NECA (Agonists) or 10

M unlabelled PSB 11.

- Buffer: 50 mM Tris-HCl, 10 mM MgCl

, 1 mM EDTA, pH 7.4. (Adenosine deaminase, 2 U/mL, is crucial to remove endogenous adenosine).

Step-by-Step Workflow

- Pre-Incubation (Adenosine Removal):
 - Incubate membranes with Adenosine Deaminase (ADA) for 30 mins at 30°C. Causality: Endogenous adenosine competes with the ligand, artificially inflating the calculated K_i .
- Binding Reaction:
 - Tube A (Total): Membrane (20-50
 - g) +

PSB-11 (0.5 - 1.0 nM).

- Tube B (Non-Specific): Membrane +

PSB-11 + 10

M Cold Competitor.

- Tube C (Test): Membrane +

PSB-11 + Test Compound (various concentrations).

- Volume: Adjust to 200-500

L with Tris Buffer.

- Equilibrium:

- Incubate for 60-90 minutes at 25°C. Note: A3 receptors internalize rapidly in whole cells; membrane preps are preferred to ensure stable surface receptor availability.

- Termination:

- Rapid filtration through GF/B filters (pre-soaked in 0.3% PEI).
- Wash 3x with ice-cold buffer.
- Causality: PEI reduces filter binding of the hydrophobic ligand; ice-cold wash prevents dissociation of the bound complex.

- Data Analysis:

- Calculate Specific Binding = (Total - Non-Specific).

- Fit to a one-site competition model to derive

.

- Convert to

using the Cheng-Prusoff equation:

.

Protocol Visualization

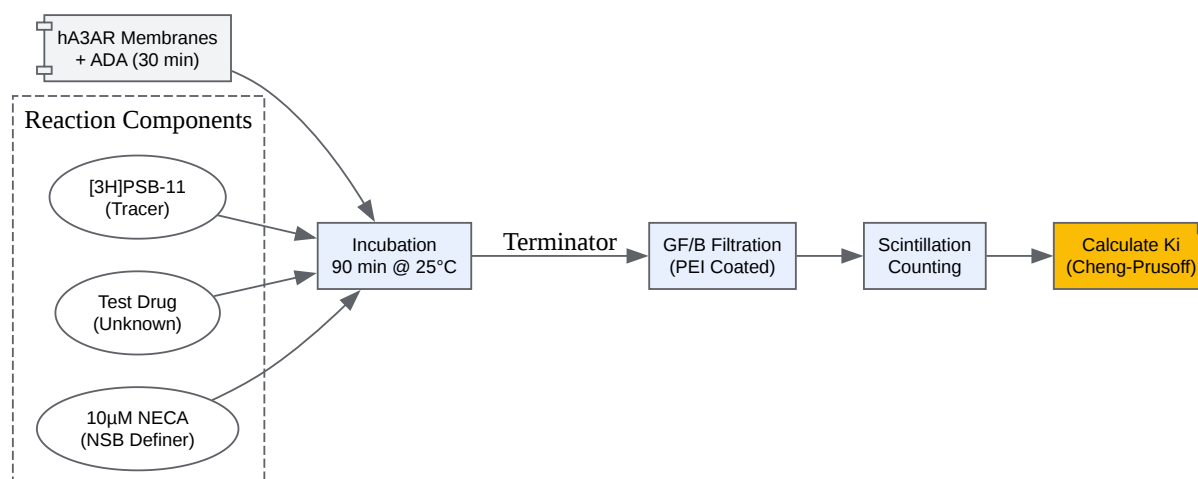

[Click to download full resolution via product page](#)

Figure 2: Radioligand binding workflow for validating A3AR affinity using PSB 11.

Cross-Reactivity Deep Dive: The "Imidazo" Advantage

The structural specificity of PSB 11 arises from its tricyclic imidazo[2,1-i]purin-5-one core.

- vs. A1 Receptor: The A1 pocket is smaller and more hydrophilic. The 8-ethyl and 2-phenyl substitutions on PSB 11 create steric clashes within the A1 transmembrane domains, resulting in

nM affinity (effectively zero cross-reactivity).

- vs. A2A Receptor: The A2A receptor accommodates bulky substituents in the N6 position (adenosine numbering) or C2 position. However, PSB 11's specific stereochemistry at the 8-position (R-configuration) is unfavorable for A2A binding, maintaining high selectivity.
- vs. A2B Receptor: Often the "off-target" for many adenosine ligands. PSB 11 shows negligible activity (nM), unlike its cousin PSB-1115, which is an A2B-selective antagonist. Caution: Do not confuse PSB 11 (A3) with PSB-1115 (A2B).

References

- Müller, C. E., et al. (2002). [3H]8-Ethyl-4-methyl-2-phenyl-(8R)-4,5,7,8-tetrahydro-1H-imidazo[2,1-i]purin-5-one ([3H]PSB-11), a novel high-affinity antagonist radioligand for human A3 adenosine receptors.[1] *Bioorganic & Medicinal Chemistry Letters*. [1]
- Jacobson, K. A., & Müller, C. E. (2016). Medicinal chemistry of adenosine, P2Y and P2X receptors. *Neuropharmacology*.
- Klotz, K. N., et al. (1998). Comparative pharmacology of human adenosine receptor subtypes - characterization of stable mammalian cell lines expressing human adenosine receptors. *Naunyn-Schmiedeberg's Archives of Pharmacology*.
- Tajiri, M., et al. (2021). Pharmacological characterization of DPTN and other selective A3 adenosine receptor antagonists.[4] *Purinergic Signalling*.

Need Custom Synthesis?

BenchChem offers custom synthesis for rare earth carbides and specific isotopic labeling.

Email: info@benchchem.com or [Request Quote Online](#).

Sources

- [1. medchemexpress.com \[medchemexpress.com\]](https://www.medchemexpress.com)
- [2. Progress in the Pursuit of Therapeutic Adenosine Receptor Antagonists - PMC \[pmc.ncbi.nlm.nih.gov\]](https://pubmed.ncbi.nlm.nih.gov/)

- [3. apexbt.com \[apexbt.com\]](#)
- [4. Pharmacological characterization of DPTN and other selective A3 adenosine receptor antagonists - PMC \[pmc.ncbi.nlm.nih.gov\]](#)
- To cite this document: BenchChem. [Definitive Guide to PSB 11 Hydrochloride: Cross-Reactivity & A3AR Selectivity]. BenchChem, [2026]. [Online PDF]. Available at: [\[https://www.benchchem.com/product/b1139462/docs#definitive-guide-to-psb-11-hydrochloride-cross-reactivity-a3ar-selectivity\]](https://www.benchchem.com/product/b1139462/docs#definitive-guide-to-psb-11-hydrochloride-cross-reactivity-a3ar-selectivity)

Disclaimer & Data Validity:

The information provided in this document is for Research Use Only (RUO) and is strictly not intended for diagnostic or therapeutic procedures. While BenchChem strives to provide accurate protocols, we make no warranties, express or implied, regarding the fitness of this product for every specific experimental setup.

Technical Support: The protocols provided are for reference purposes. Unsure if this reagent suits your experiment?

Need Industrial/Bulk Grade? [Request Custom Synthesis Quote](#)

BenchChem

Our mission is to be the trusted global source of essential and advanced chemicals, empowering scientists and researchers to drive progress in science and industry.

Contact

Address: 3281 E Guasti Rd
Ontario, CA 91761, United States
Phone: (601) 213-4426
Email: info@benchchem.com

[Contact our Ph.D. Support Team for a compatibility check](#)

