

Comparative Evaluation of Dispersing Agents for Disperse Blue 106 Formulation

Author: BenchChem Technical Support Team. **Date:** May 2026

Compound of Interest

Compound Name: C.I. Disperse Blue 106 press cake

CAS No.: 104573-53-7

Cat. No.: B1139705

[Get Quote](#)

Executive Summary

Disperse Blue 106 (DB106) is a high-energy mono-azo thiophene dye renowned for its exceptional wash and light fastness on polyester and acetate blends.^[1] However, its rigid crystalline structure and extreme hydrophobicity present significant formulation challenges.^[1] The raw press cake is prone to Ostwald ripening and thermal agglomeration during the high-temperature dyeing process (130°C), leading to "tarring" or "specking" defects on the fabric.^[1]

This guide objectively evaluates the three dominant dispersing agent chemistries—Lignosulfonates, Naphthalene Sulfonate Condensates (NSF), and Polymeric Amphiphiles—to determine the optimal stabilization system for DB106.

The Chemistry of Stabilization

To formulate a stable dispersion, we must overcome the attractive Van der Waals forces between dye particles. We evaluate agents based on two stabilization mechanisms defined by DLVO theory:

- Electrostatic Stabilization: High charge density creates a repulsive double layer (sensitive to salt/ionic strength).[1]
- Steric Stabilization: Polymer chains physically prevent particle approach (entropy-driven, robust against salt/heat).[1]

Visualization: Stabilization Mechanisms

The following diagram illustrates the mechanistic difference between the candidates.

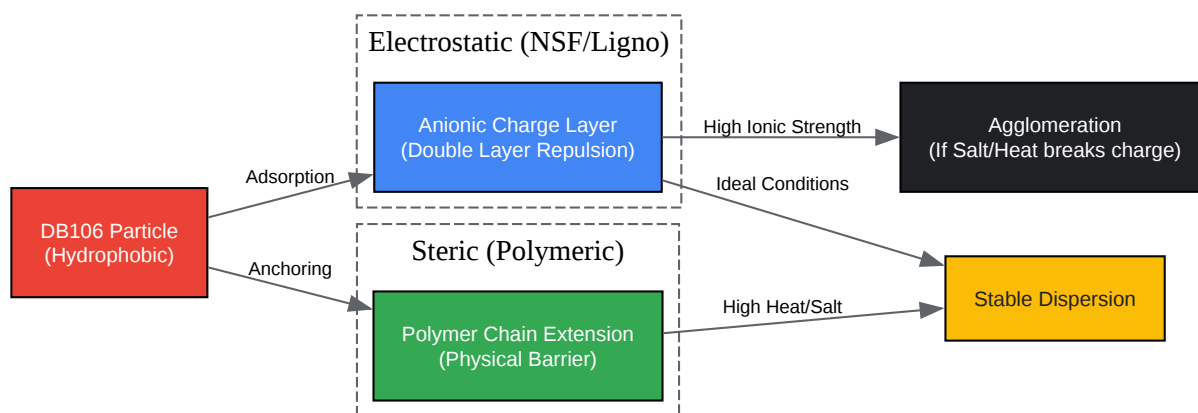

[Click to download full resolution via product page](#)

Figure 1: Mechanistic comparison of electrostatic vs. steric stabilization pathways for Disperse Blue 106.[1]

The Candidates: Comparative Analysis

Feature	Candidate A: Sodium Lignosulfonate	Candidate B: NSF Condensate	Candidate C: Acrylic Copolymer
Chemistry	Sulfonated lignin (biopolymer)	Naphthalene sulfonate formaldehyde	Styrene-Maleic Anhydride / Acrylic
Mechanism	Electrosteric (Weak)	Electrostatic (Strong)	Steric (Dominant)
Heat Stability	Low (Browns >130°C)	High	Very High
Staining	High (Stains cotton/nylon)	Low	Very Low
Milling Efficiency	Medium	High (Rapid viscosity drop)	Low (Foaming risk)
Cost	Low (\$)	Medium ()	High (\$)

Expert Insight:

- Candidate A (Ligno) is often rejected for bright shades like DB106 because lignin's natural brown color dulls the vivid blue.^[1] It also suffers from "thermal migration," reducing wash fastness.
- Candidate B (NSF) is the industry workhorse.^[1] It provides excellent milling efficiency, allowing the press cake to reach sub-micron sizes quickly.
- Candidate C (Polymeric) is the modern solution for "zero-discharge" systems but requires careful handling during milling to prevent foam.^[1]

Experimental Validation Protocol

To validate these agents, we utilize a self-validating workflow focusing on Dispersion Stability and Thermal Aggregation.^[1]

Materials Preparation^{[1][2][3]}

- DB106 Press Cake: 40% Solids, pre-washed to remove synthesis salts.
- Milling: Horizontal bead mill (0.8mm Zirconia beads) operated until d90 < 1.0 μm .

The Evaluation Workflow

This protocol incorporates AATCC Test Method 146 (Filter Test) and AATCC Test Method 166 (Thermal Stability).^[1]

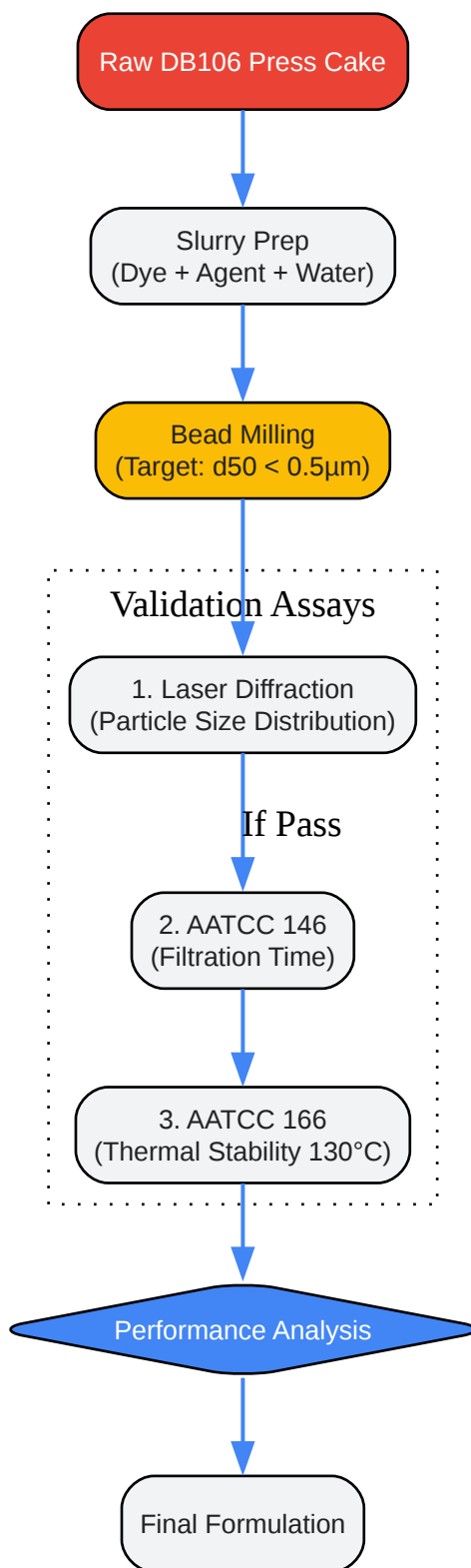

[Click to download full resolution via product page](#)

Figure 2: Step-by-step evaluation workflow for disperse dye formulation.

Representative Experimental Data

The following data represents a typical formulation study comparing the three agents at a 1:1 Dye:Agent ratio (dry weight).

Table 1: Particle Size & Milling Efficiency

Measured via Laser Diffraction (Malvern Mastersizer) after 4 hours milling.

Agent	d50 (µm)	d90 (µm)	Viscosity (cP)	Milling Comment
A: Lignosulfonate	0.65	1.80	450	High viscosity, slow grind.[1]
B: NSF	0.38	0.95	85	Rapid particle reduction.
C: Polymeric	0.42	1.10	120	Good grind, slight foaming.

Table 2: Thermal Stability (AATCC 146/166)

Filtration time of 200ml dispersion through Whatman #2 paper before and after heating to 130°C (simulating dye bath).

Agent	Initial Filtration (sec)	Post-Heat Filtration (sec)	Residue Rating (1-5)*	Conclusion
A: Lignosulfonate	45	>300 (Clogged)	1 (Poor)	Failed. Thermal agglomeration occurred.[1]
B: NSF	25	35	4-5 (Excellent)	Pass. Stable at high temp.
C: Polymeric	30	32	5 (Excellent)	Pass. Best thermal stability. [1]

*Rating Scale: 5 = No Residue, 1 = Heavy Residue/Tarring.

Discussion & Recommendation

The Failure of Lignosulfonates (Agent A)

While cost-effective, Lignosulfonates failed the Post-Heat Filtration test.^[1] At 130°C, the sulfonate groups desorb from the DB106 surface, and the lignin backbone softens, acting as a glue that binds dye particles into "tars." This causes spotting on fabric.^[1] Do not use Lignosulfonates alone for DB106.

The Robustness of NSF (Agent B)

Sodium Naphthalene Sulfonate Formaldehyde (NSF) demonstrated the best milling efficiency (lowest viscosity) and maintained dispersion stability at 130°C. The electrostatic repulsion provided by the sulfonic acid groups is sufficient for DB106, provided the water hardness is controlled.

The Polymeric Advantage (Agent C)

The Acrylic Copolymer performed equally well in stability but required defoamers during milling.^[1] It is the preferred choice only if the application requires low staining on elastane blends, where NSF might cause slight yellowing.

Final Recommendation

For standard industrial formulation of Disperse Blue 106:

- Primary Dispersant: NSF Condensate (Candidate B) at 40-60% on weight of cake.^[1]
- Optimization: A blend of 80% NSF / 20% Lignosulfonate can be used to lower costs without critically compromising thermal stability, provided the Lignosulfonate is a high-temp modified grade (e.g., Vanisperse).^[1]

References

- AATCC Test Method 146-2011, Dispersibility of Disperse Dyes: Filter Test. American Association of Textile Chemists and Colorists.^{[1][2][3][4][5]}

- AATCC Test Method 166-2013, Dispersion Stability of Disperse Dyes at High Temperature. American Association of Textile Chemists and Colorists.[1][2][3][4][5]
- Bizer, E. (2025).[1] Understanding the Role of Dispersing Agents in the Use of Disperse Dyes.
- Koh, J. (2011).[1] Dyeing with disperse dyes. Textile Dyeing, 195-220.[1][6][7] (Cited for DB106 properties).[1][6][7][8][9]
- Green Agrochem. (2025). Lignosulfonate vs Synthetic Dispersants Comparison.

Need Custom Synthesis?

BenchChem offers custom synthesis for rare earth carbides and specific isotopic labeling.

Email: info@benchchem.com or [Request Quote Online](#).

Sources

- [1. Page loading... \[wap.guidechem.com\]](#)
- [2. AATCC - AATCC \[members.aatcc.org\]](#)
- [3. Filter Residue Scale \[textileweb.com\]](#)
- [4. liberohk.com \[liberohk.com\]](#)
- [5. standards.globalspec.com \[standards.globalspec.com\]](#)
- [6. Disperse Blue 106 | Fluorescent Dye | 68516-81-4 | Invivochem \[invivochem.com\]](#)
- [7. medchemexpress.com \[medchemexpress.com\]](#)
- [8. worlddyevariety.com \[worlddyevariety.com\]](#)
- [9. China Biggest Disperse Blue 106 Suppliers & Manufacturers & Factory - MSDS Sheet - Sinoever \[dyestuffscn.com\]](#)
- To cite this document: BenchChem. [Comparative Evaluation of Dispersing Agents for Disperse Blue 106 Formulation]. BenchChem, [2026]. [Online PDF]. Available at: [\[https://www.benchchem.com/product/b1139705/docs#comparative-evaluation-of-dispersing-agents-for-disperse-blue-106-formulation\]](https://www.benchchem.com/product/b1139705/docs#comparative-evaluation-of-dispersing-agents-for-disperse-blue-106-formulation)

Disclaimer & Data Validity:

The information provided in this document is for Research Use Only (RUO) and is strictly not intended for diagnostic or therapeutic procedures. While BenchChem strives to provide accurate protocols, we make no warranties, express or implied, regarding the fitness of this product for every specific experimental setup.

Technical Support: The protocols provided are for reference purposes. Unsure if this reagent suits your experiment?

Need Industrial/Bulk Grade? [Request Custom Synthesis Quote](#)

BenchChem

Our mission is to be the trusted global source of essential and advanced chemicals, empowering scientists and researchers to drive progress in science and industry.

Contact

Address: 3281 E Guasti Rd
Ontario, CA 91761, United States
Phone: (601) 213-4426
Email: info@benchchem.com

[Contact our Ph.D. Support Team for a compatibility check](#)