

# Technical Support Center: Optimizing C450-0730 Incubation Time

**Author:** BenchChem Technical Support Team. **Date:** December 2025

## Compound of Interest

Compound Name: C450-0730

Cat. No.: B11037527

[Get Quote](#)

Introduction: This technical support center provides researchers, scientists, and drug development professionals with comprehensive guidance on optimizing the incubation time for **C450-0730**, a potent and selective inhibitor of the PI3K/Akt/mTOR signaling pathway. Proper incubation time is critical for achieving maximal therapeutic effect while minimizing off-target effects and cytotoxicity. This guide offers troubleshooting advice, detailed experimental protocols, and data interpretation resources in a user-friendly question-and-answer format.

## Frequently Asked Questions (FAQs) & Troubleshooting

Q1: What is the recommended starting incubation time for **C450-0730** in a cell-based assay?

A1: The optimal incubation time for **C450-0730** is highly dependent on the specific cell line and the biological question being addressed. For initial experiments, we recommend a time-course experiment to determine the ideal duration.

- For assessing downstream signaling inhibition (e.g., phosphorylation of Akt or S6K): A shorter incubation time is generally sufficient. We recommend starting with a time course of 30 minutes, 1, 2, 4, and 8 hours.[1]
- For evaluating effects on cell viability or proliferation (e.g., MTT or colony formation assays): A longer incubation period is typically necessary to observe significant changes. We suggest starting with 24, 48, and 72-hour time points.[1]

Q2: My results show high variability between replicate wells. What could be the cause?

A2: High variability in replicate wells is a common issue in cell-based assays and can stem from several factors.<sup>[2][3]</sup>

- **Inconsistent Cell Seeding:** Ensure your cell suspension is homogenous before and during plating. Allow the plate to sit at room temperature on a level surface for 15-20 minutes before incubation to promote even cell distribution.<sup>[2]</sup>
- **Pipetting Errors:** Calibrate your pipettes regularly and use appropriate pipetting techniques, such as reverse pipetting for viscous solutions.<sup>[2][3]</sup>
- **Edge Effects:** The outer wells of a microplate are prone to evaporation and temperature fluctuations.<sup>[2][3]</sup> It is best to avoid using these wells for experimental samples and instead fill them with sterile media or PBS to create a humidity barrier.<sup>[2]</sup>

Q3: I am not observing the expected inhibitory effect of **C450-0730** on my target pathway, even at high concentrations. What should I troubleshoot?

A3: Several factors could contribute to a lack of efficacy. Consider the following troubleshooting steps:

- **Incubation Time:** The incubation time may be too short for the inhibitor to exert its effect. Conversely, for some targets, the inhibitory effect can be transient. A time-course experiment is crucial.
- **Compound Stability:** Verify the stability of **C450-0730** in your specific cell culture media at 37°C. Degradation of the compound will lead to a loss of activity.
- **Cell Line Resistance:** The cell line you are using may have intrinsic or acquired resistance mechanisms, such as mutations in the PI3K/Akt/mTOR pathway or upregulation of compensatory signaling pathways.<sup>[4]</sup>
- **ATP Concentration:** As **C450-0730** is an ATP-competitive inhibitor, high intracellular ATP concentrations can reduce its apparent potency.<sup>[3][5]</sup>

Q4: I am observing significant cytotoxicity at concentrations where I expect to see specific inhibition. How can I mitigate this?

A4: Distinguishing between on-target cytotoxic effects and off-target toxicity is crucial.

- **Optimize Concentration and Incubation Time:** Perform a detailed dose-response and time-course experiment to identify a therapeutic window where you observe target inhibition with minimal cytotoxicity.
- **Assess Off-Target Effects:** Consider performing kinome profiling to assess the selectivity of **C450-0730**.<sup>[6]</sup> Comparing the phenotype with other inhibitors targeting the same pathway but with different chemical scaffolds can also be informative.<sup>[6]</sup>
- **Rescue Experiments:** If possible, perform rescue experiments by overexpressing a drug-resistant mutant of the target kinase. This can help confirm that the observed cytotoxicity is an on-target effect.<sup>[6]</sup>

## Data Presentation

Table 1: Effect of Incubation Time on **C450-0730** IC50 in A549 Cells

Incubation Time (hours)	IC50 (nM) for p-Akt (S473) Inhibition	IC50 (nM) for Cell Viability (MTT Assay)
2	15.2 ± 2.1	> 10,000
8	12.8 ± 1.9	8,543 ± 976
24	14.1 ± 2.5	1,234 ± 154
48	Not Determined	452 ± 58
72	Not Determined	211 ± 32

Table 2: Cytotoxicity Profile of **C450-0730** in HEK293 Cells

Concentration (nM)	% Viability at 24 hours	% Viability at 48 hours	% Viability at 72 hours
100	98.7 ± 2.3	95.4 ± 3.1	92.1 ± 4.5
500	96.2 ± 3.1	88.1 ± 4.2	75.6 ± 5.8
1000 (1µM)	90.5 ± 4.5	72.3 ± 5.5	51.2 ± 6.2
5000 (5µM)	65.8 ± 5.9	41.7 ± 6.8	22.4 ± 4.9
10000 (10µM)	42.1 ± 6.2	15.9 ± 4.1	5.7 ± 2.1

## Experimental Protocols

### Protocol 1: Time-Course Western Blot for p-Akt Inhibition

- Cell Seeding: Plate cells at a density that will result in 70-80% confluency at the time of the experiment.
- Treatment: Treat cells with the desired concentration of **C450-0730** for various time points (e.g., 0, 0.5, 1, 2, 4, 8 hours).
- Cell Lysis: Wash cells with ice-cold PBS and lyse with RIPA buffer supplemented with protease and phosphatase inhibitors.[1]
- Protein Quantification: Determine the protein concentration of each lysate using a BCA assay.[7]
- SDS-PAGE and Transfer: Load equal amounts of protein onto an SDS-PAGE gel, run the gel, and transfer the proteins to a PVDF membrane.[8]
- Antibody Incubation: Block the membrane and incubate with primary antibodies against p-Akt (S473), total Akt, and a loading control (e.g., GAPDH or β-actin) overnight at 4°C.[7] Follow with incubation with the appropriate HRP-conjugated secondary antibody for 1 hour at room temperature.[7][8]
- Detection: Visualize the protein bands using an ECL substrate and an imaging system.

## Protocol 2: Cell Viability MTT Assay

- Cell Seeding: Seed cells in a 96-well plate at a predetermined optimal density.[9]
- Treatment: After allowing the cells to adhere overnight, treat them with a serial dilution of **C450-0730** for the desired incubation times (e.g., 24, 48, 72 hours).
- MTT Addition: Add MTT solution (final concentration 0.5 mg/mL) to each well and incubate for 3-4 hours at 37°C.[10]
- Solubilization: Add a solubilization solution (e.g., DMSO or a solution of SDS in HCl) to dissolve the formazan crystals.[9]
- Absorbance Reading: Measure the absorbance at 570 nm using a microplate reader.[9][11]

## Mandatory Visualizations

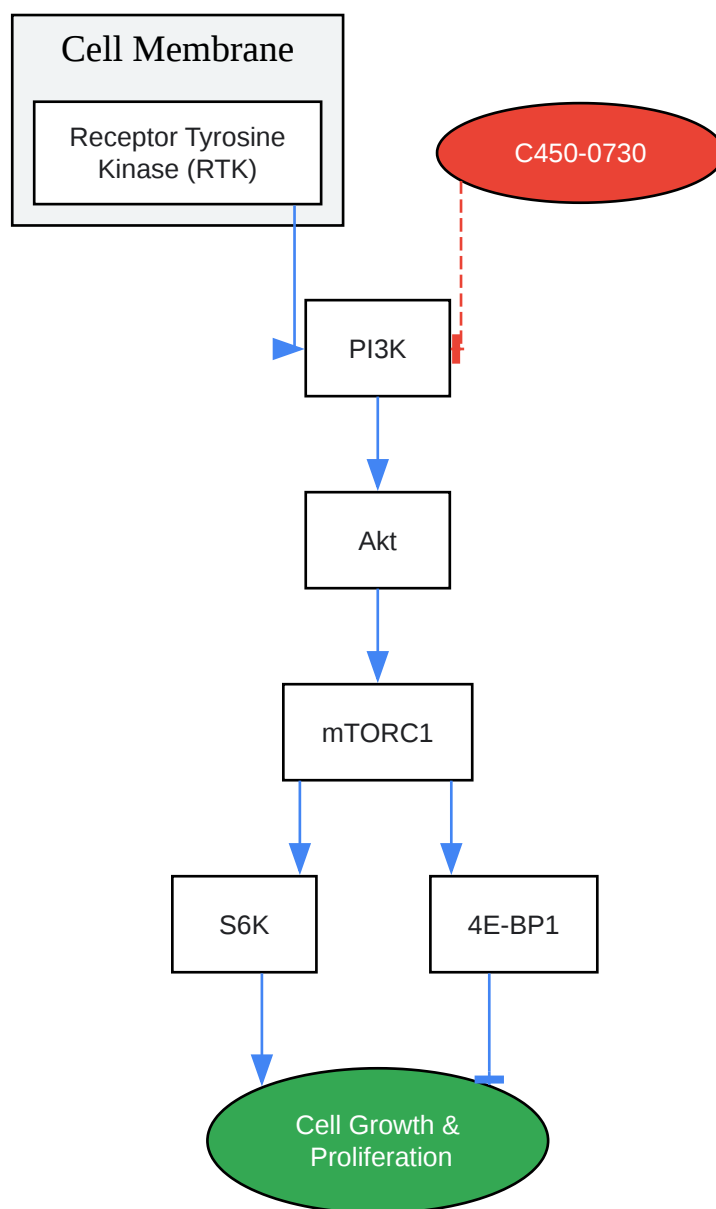

[Click to download full resolution via product page](#)

Caption: **C450-0730** inhibits the PI3K/Akt/mTOR signaling pathway.

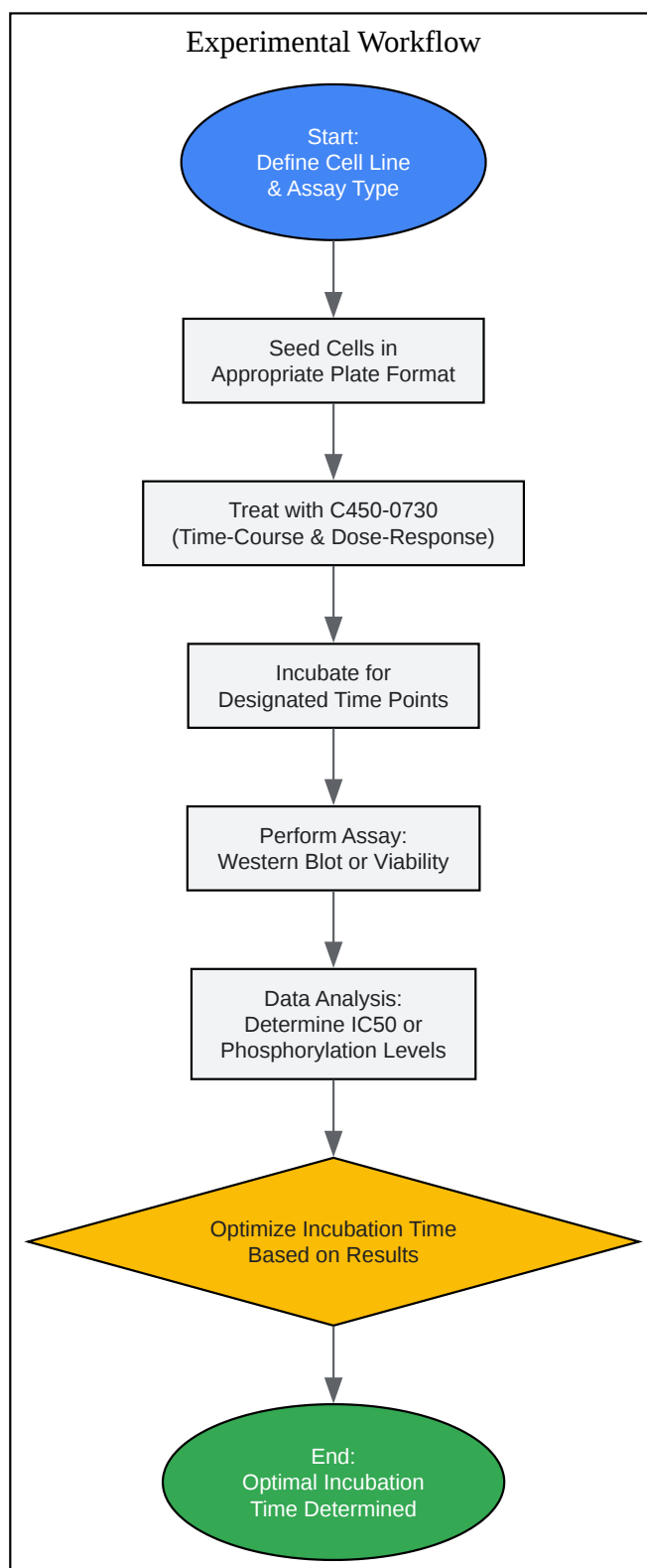

[Click to download full resolution via product page](#)

Caption: Workflow for optimizing **C450-0730** incubation time.

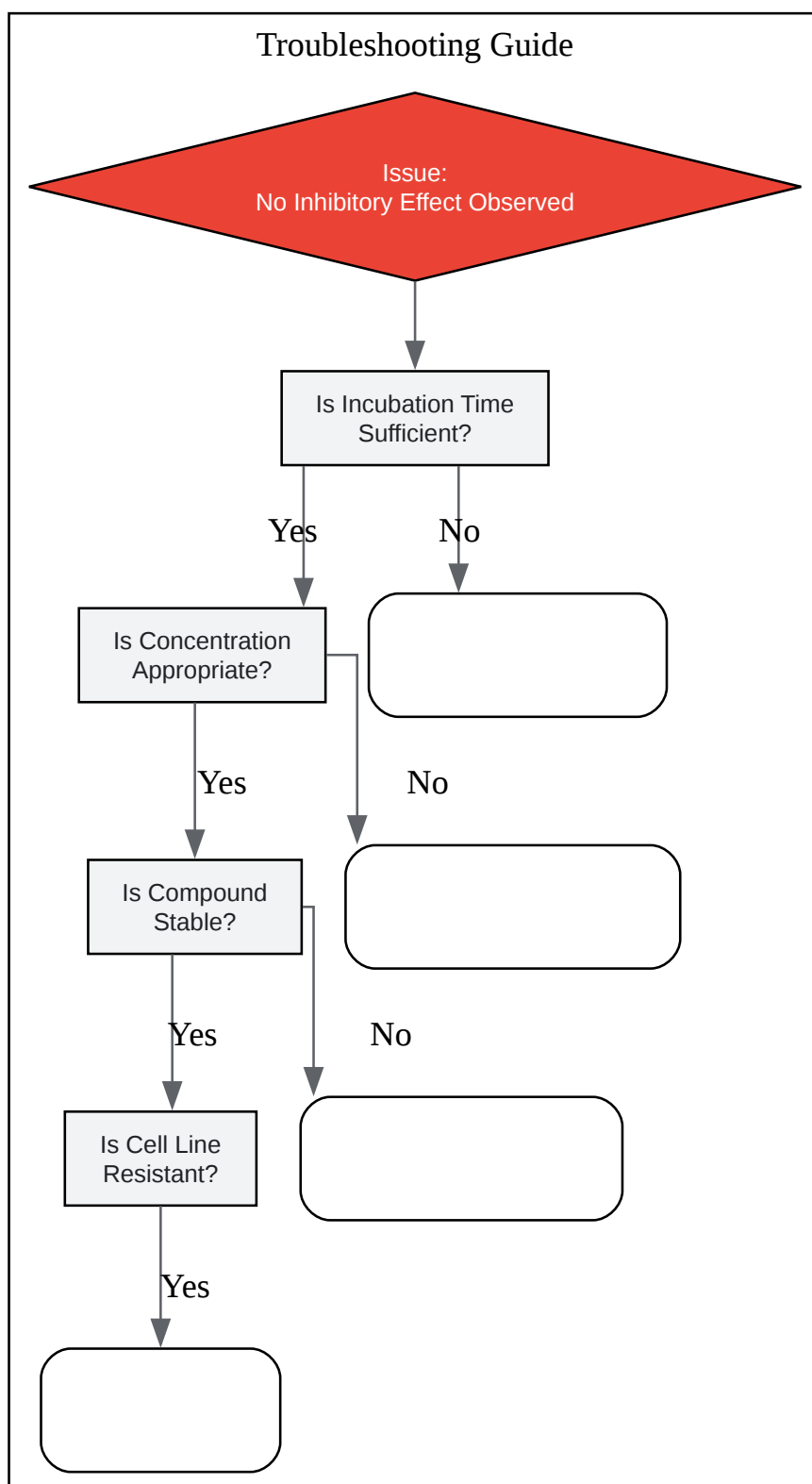

[Click to download full resolution via product page](#)



### Need Custom Synthesis?

BenchChem offers custom synthesis for rare earth carbides and specific isotopic labeling.

Email: [info@benchchem.com](mailto:info@benchchem.com) or [Request Quote Online](#).

## References

- 1. benchchem.com [benchchem.com]
- 2. benchchem.com [benchchem.com]
- 3. benchchem.com [benchchem.com]
- 4. The PI3K/AKT/mTOR pathway in breast cancer: targets, trials and biomarkers - PMC [pmc.ncbi.nlm.nih.gov]
- 5. Assessing the Inhibitory Potential of Kinase Inhibitors In Vitro: Major Pitfalls and Suggestions for Improving Comparability of Data Using CK1 Inhibitors as an Example - PMC [pmc.ncbi.nlm.nih.gov]
- 6. benchchem.com [benchchem.com]
- 7. blog.addgene.org [blog.addgene.org]
- 8. Experimental Protocol for Western Blotting Clinisciences [clinisciences.com]
- 9. CyQUANT MTT Cell Proliferation Assay Kit Protocol | Thermo Fisher Scientific - JP [thermofisher.com]
- 10. broadpharm.com [broadpharm.com]
- 11. MTT assay protocol | Abcam [abcam.com]
- To cite this document: BenchChem. [Technical Support Center: Optimizing C450-0730 Incubation Time]. BenchChem, [2025]. [Online PDF]. Available at: [https://www.benchchem.com/product/b11037527#optimizing-c450-0730-incubation-time-for-maximal-effect]

---

### Disclaimer & Data Validity:

The information provided in this document is for Research Use Only (RUO) and is strictly not intended for diagnostic or therapeutic procedures. While BenchChem strives to provide accurate protocols, we make no warranties, express or implied, regarding the fitness of this product for every specific experimental setup.

**Technical Support:** The protocols provided are for reference purposes. Unsure if this reagent suits your experiment? [[Contact our Ph.D. Support Team for a compatibility check](#)]

**Need Industrial/Bulk Grade?** [Request Custom Synthesis Quote](#)

## BenchChem

Our mission is to be the trusted global source of essential and advanced chemicals, empowering scientists and researchers to drive progress in science and industry.

### Contact

Address: 3281 E Guasti Rd

Ontario, CA 91761, United States

Phone: (601) 213-4426

Email: [info@benchchem.com](mailto:info@benchchem.com)