

In-Depth Technical Guide: 6-Chloropyridazine-4-carboxylic acid

Author: BenchChem Technical Support Team. **Date:** May 2026

Compound of Interest

Compound Name:	6-Chloropyridazine-4-carboxylic acid
CAS No.:	1256794-24-7
Cat. No.:	B110448

[Get Quote](#)

CAS Number: 1256794-24-7

For Researchers, Scientists, and Drug Development Professionals

This technical guide provides a comprehensive overview of **6-Chloropyridazine-4-carboxylic acid**, a heterocyclic building block with significant potential in medicinal chemistry and drug discovery. The document details its chemical and physical properties, provides a likely synthetic protocol, outlines expected analytical data, and explores its applications, particularly in the development of novel therapeutics.

Chemical Properties

6-Chloropyridazine-4-carboxylic acid is a chlorinated pyridazine derivative. The presence of the chlorine atom, carboxylic acid, and the pyridazine ring makes it a versatile scaffold for chemical modification.

Property	Value	Source
Molecular Formula	C ₅ H ₃ ClN ₂ O ₂	
Molecular Weight	158.54 g/mol	
IUPAC Name	6-chloropyridazine-4-carboxylic acid	
SMILES	<chem>O=C(O)c1cnnc(Cl)c1</chem>	
InChIKey	GYRNORMCWYVKCT-UHFFFAOYSA-N	
Purity	Typically ≥95% - 97%	
Appearance	Off-white solid	
Storage	2-8 °C, under inert atmosphere	

Synthesis and Purification

While a specific, peer-reviewed synthesis for **6-chloropyridazine-4-carboxylic acid** is not readily available in the public domain, a likely and chemically sound method can be inferred from patented procedures for its isomer, 6-chloropyridazine-3-carboxylic acid. The most common approach involves the oxidation of a corresponding methyl-substituted pyridazine.

Experimental Protocol: Oxidation of 4-methyl-6-chloropyridazine

This protocol is adapted from the synthesis of a related isomer and represents a probable route. Researchers should perform their own optimization and safety assessments.

Reaction Scheme:

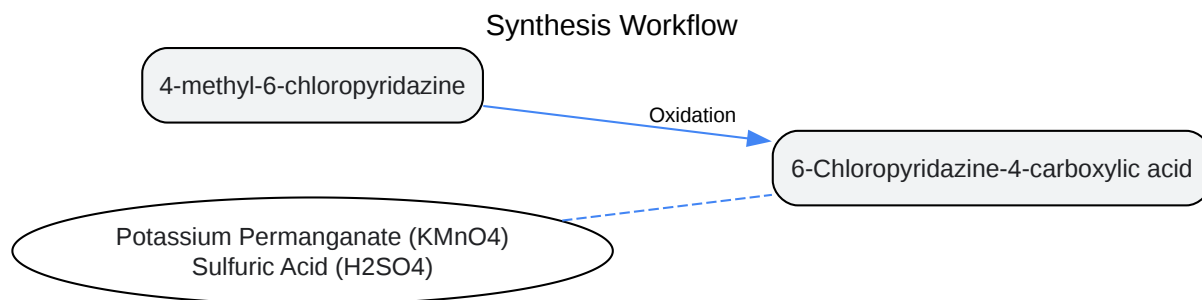

[Click to download full resolution via product page](#)

Caption: Probable synthesis route for **6-Chloropyridazine-4-carboxylic acid**.

Materials:

- 4-methyl-6-chloropyridazine
- Potassium permanganate (KMnO₄)
- Concentrated sulfuric acid (H₂SO₄)
- Ice
- Ethyl acetate
- Anhydrous sodium sulfate (Na₂SO₄)
- Methanol (for recrystallization)

Procedure:

- Reaction Setup: In a three-necked flask equipped with a mechanical stirrer and a thermometer, carefully add 4-methyl-6-chloropyridazine to concentrated sulfuric acid while cooling in an ice bath.
- Oxidation: Slowly add powdered potassium permanganate in portions, ensuring the internal temperature does not exceed 50-60 °C.

- **Reaction Monitoring:** After the addition is complete, allow the mixture to stir at a controlled temperature (e.g., 50 °C) for several hours. Monitor the reaction progress using an appropriate technique like Thin Layer Chromatography (TLC).
- **Quenching:** Once the reaction is complete, carefully pour the reaction mixture over a large volume of crushed ice with stirring.
- **Extraction:** Extract the aqueous solution multiple times with ethyl acetate.
- **Drying and Concentration:** Combine the organic extracts and dry over anhydrous sodium sulfate. Filter and concentrate the solvent under reduced pressure to obtain the crude product.
- **Purification:** Recrystallize the crude solid from a suitable solvent, such as methanol, to yield the purified **6-chloropyridazine-4-carboxylic acid**.

Spectroscopic and Physical Data

Detailed experimental spectra for this specific compound are not widely published. The following tables provide expected data based on the chemical structure and general spectroscopic principles.

Nuclear Magnetic Resonance (NMR) Spectroscopy (Predicted)

Nucleus	Predicted Chemical Shift (δ) ppm	Multiplicity	Notes
^1H NMR	~8.0 - 8.5	Singlet	Proton on the pyridazine ring adjacent to the carboxylic acid.
	~9.0 - 9.5	Singlet	Proton on the pyridazine ring adjacent to the chlorine.
	~13.0 - 14.0	Broad Singlet	Acidic proton of the carboxylic acid group.
^{13}C NMR	~165 - 170	Singlet	Carbonyl carbon of the carboxylic acid.
	~150 - 160	Singlet	Carbon atoms of the pyridazine ring attached to chlorine and nitrogen.
	~130 - 140	Singlet	Carbon atoms of the pyridazine ring.

Infrared (IR) Spectroscopy (Predicted)

Wavenumber (cm ⁻¹)	Intensity	Vibration
2500-3300	Broad, Strong	O-H stretch (from carboxylic acid dimer)
1710-1760	Strong	C=O stretch (carbonyl of carboxylic acid)
1550-1600	Medium	C=N and C=C stretching in the pyridazine ring
1200-1300	Medium-Strong	C-O stretch
700-800	Medium	C-Cl stretch

Mass Spectrometry (MS) (Predicted)

m/z	Interpretation
158/160	Molecular ion peak (M ⁺) and its isotope peak (M+2) due to the presence of Chlorine-35 and Chlorine-37 in a ~3:1 ratio.
141/143	Loss of OH radical (M-17).
113/115	Loss of COOH group (M-45).

Applications in Drug Discovery

6-Chloropyridazine-4-carboxylic acid is a valuable building block in medicinal chemistry due to its functional handles that allow for diverse chemical modifications.

Antiviral and Antibacterial Research

Pyridazine derivatives are known to exhibit a wide range of biological activities, including antiviral and antibacterial properties. The presence of a carboxylic acid allows for the formation of amides, esters, and other derivatives, which can be explored for their potential as novel antimicrobial agents. The chlorine atom can also be substituted via nucleophilic aromatic substitution to introduce further diversity.

Protein Degraders (PROTACs)

This molecule is particularly relevant in the field of targeted protein degradation. Proteolysis-targeting chimeras (PROTACs) are bifunctional molecules that induce the degradation of specific proteins. They typically consist of a ligand for a target protein and a ligand for an E3 ubiquitin ligase, connected by a linker. **6-Chloropyridazine-4-carboxylic acid** can serve as a rigid core or a component of the linker in PROTAC design. The carboxylic acid can be functionalized to connect to either the target protein ligand or the E3 ligase ligand.

PROTAC Mechanism of Action

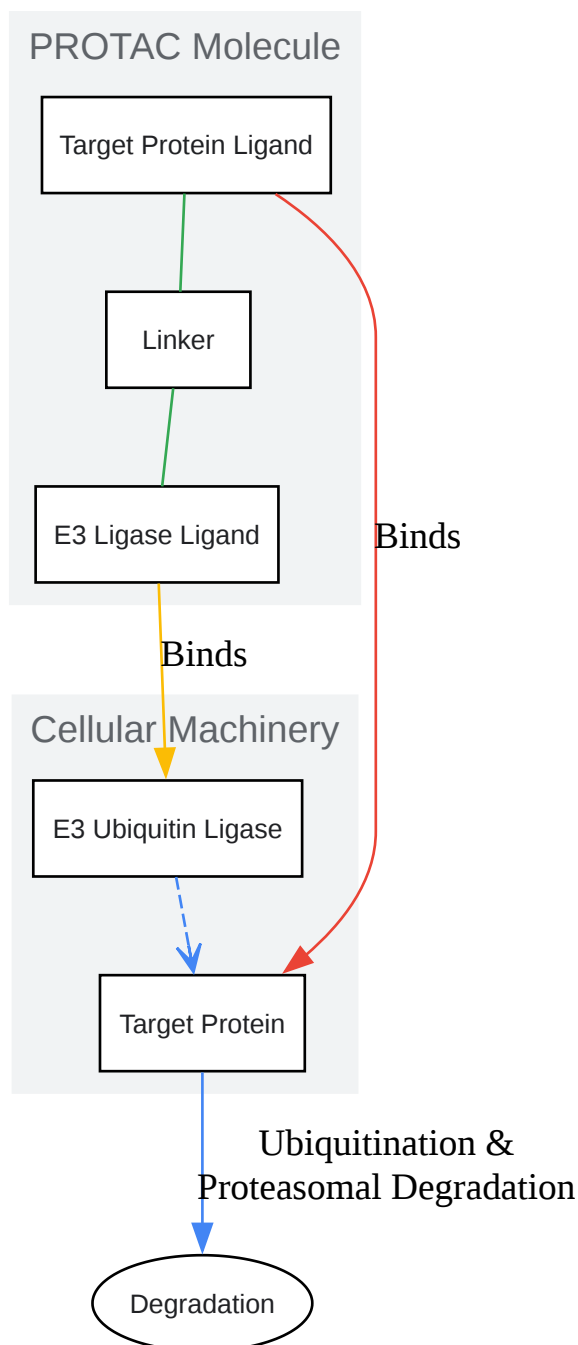

[Click to download full resolution via product page](#)

Caption: General mechanism of action for a PROTAC molecule.

Safety Information

Hazard Statements:

- Harmful if swallowed.
- Causes skin irritation.
- Causes serious eye irritation.
- May cause respiratory irritation.

Precautionary Statements:

- Avoid breathing dust/fume/gas/mist/vapors/spray.
- Wash skin thoroughly after handling.
- Wear protective gloves/protective clothing/eye protection/face protection.

For detailed safety information, please consult the Safety Data Sheet (SDS) from the supplier.

- To cite this document: BenchChem. [In-Depth Technical Guide: 6-Chloropyridazine-4-carboxylic acid]. BenchChem, [2026]. [Online PDF]. Available at: [\[https://www.benchchem.com/product/b110448/docs#in-depth-technical-guide-6-chloropyridazine-4-carboxylic-acid\]](https://www.benchchem.com/product/b110448/docs#in-depth-technical-guide-6-chloropyridazine-4-carboxylic-acid)

Disclaimer & Data Validity:

The information provided in this document is for Research Use Only (RUO) and is strictly not intended for diagnostic or therapeutic procedures. While BenchChem strives to provide accurate protocols, we make no warranties, express or implied, regarding the fitness of this product for every specific experimental setup.

Technical Support: The protocols provided are for reference purposes. Unsure if this reagent suits your experiment?

Need Industrial/Bulk Grade? [Request Custom Synthesis Quote](#)

BenchChem

Our mission is to be the trusted global source of essential and advanced chemicals, empowering scientists and researchers to drive progress in science and industry.

Contact

Address: 3281 E Guasti Rd

Ontario, CA 91761, United States

Phone: (601) 213-4426

Email: info@benchchem.com

[Contact our Ph.D. Support Team for a compatibility check](#)