

# Application Notes & Protocols: Atalafoline for Targeted Drug Delivery Research

**Author:** BenchChem Technical Support Team. **Date:** December 2025

## Compound of Interest

Compound Name: Atalafoline

Cat. No.: B011924

[Get Quote](#)

For Researchers, Scientists, and Drug Development Professionals

## Introduction

**Atalafoline** is a novel synthetic quinoline derivative that has demonstrated significant potential as a payload for targeted drug delivery systems, particularly in the context of oncology.[1][2] Its mechanism of action is believed to involve the inhibition of key signaling pathways implicated in tumor cell proliferation and survival. This document provides detailed application notes and protocols for the formulation, characterization, and in vitro evaluation of **Atalafoline**-loaded nanoparticles for targeted cancer therapy research.

## Data Presentation

**Table 1: Physicochemical Properties of Atalafoline**

Property	Value
Molecular Formula	C <sub>22</sub> H <sub>20</sub> N <sub>2</sub> O <sub>4</sub>
Molecular Weight	376.41 g/mol
Appearance	Yellow crystalline solid
Solubility	Soluble in DMSO, sparingly soluble in ethanol, insoluble in water
Purity (HPLC)	>98%

## Table 2: Characterization of Atalafoline-Loaded Nanoparticles

Formulation	Particle Size (nm)[3][4][5]	Polydispersity Index (PDI)[5][6]	Zeta Potential (mV)[5][7]	Encapsulation Efficiency (%) [3][4][7]	Drug Loading (%) [3][4]
Atalafoline-PLGA-NPs	155.2 ± 4.8	0.15 ± 0.02	-18.5 ± 1.2	88.3 ± 3.1	8.1 ± 0.5
FA-Atalafoline-PLGA-NPs	162.7 ± 5.1	0.17 ± 0.03	-15.2 ± 1.5	85.1 ± 2.9	7.8 ± 0.4
Atalafoline-Lipo	120.4 ± 6.3	0.21 ± 0.04	-12.8 ± 2.1	75.6 ± 4.5	6.2 ± 0.7
FA-Atalafoline-Lipo	128.9 ± 5.9	0.19 ± 0.02	-10.5 ± 1.8	72.4 ± 3.8	5.9 ± 0.6

Data are presented as mean ± standard deviation (n=3). PLGA: Poly(lactic-co-glycolic acid); FA: Folic Acid; Lipo: Liposome; NPs: Nanoparticles.

## Table 3: In Vitro Cytotoxicity of Atalafoline Formulations in MCF-7 Cells (IC<sub>50</sub> Values in μM)

Formulation	24 hours	48 hours	72 hours
Free Atalafoline	15.8 ± 1.2	8.2 ± 0.9	4.1 ± 0.5
Atalafoline-PLGA-NPs	12.5 ± 1.1	6.5 ± 0.7	3.2 ± 0.4
FA-Atalafoline-PLGA-NPs	8.1 ± 0.9	3.9 ± 0.5	1.8 ± 0.2

Data are presented as mean ± standard deviation (n=3). IC<sub>50</sub> values were determined by MTT assay.

## Signaling Pathways

### Proposed Mechanism of Action for Atalafoline

**Atalafoline** is hypothesized to exert its anti-tumor effects by inhibiting the HER1 (EGFR) signaling pathway, which is frequently overactivated in various cancers.[8] Inhibition of this pathway can lead to decreased cell proliferation, survival, and angiogenesis.

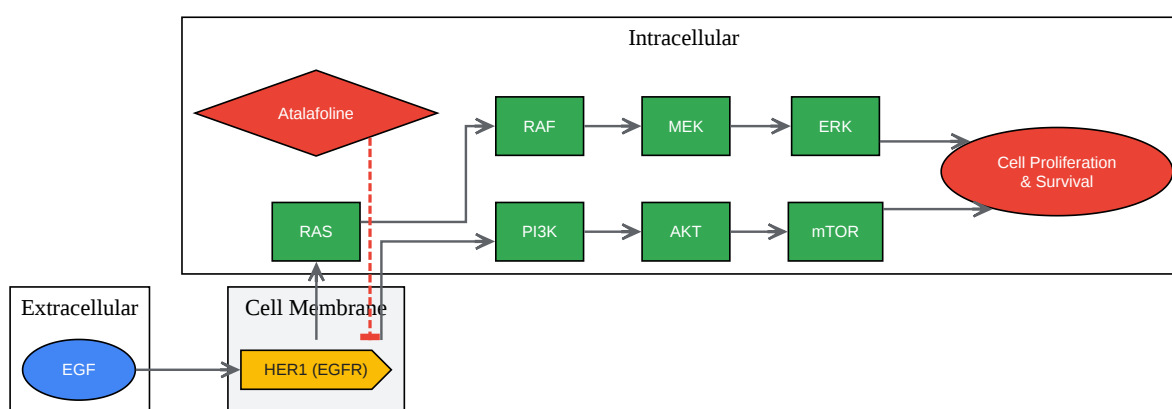

[Click to download full resolution via product page](#)

Caption: Proposed inhibition of the HER1 signaling pathway by **Atalafoline**.

## Experimental Protocols

### Protocol 1: Formulation of Folic Acid-Conjugated Atalafoline-PLGA Nanoparticles (FA-Atalafoline-PLGA-NPs)

This protocol describes the synthesis of targeted nanoparticles using an oil-in-water single emulsion solvent evaporation method.[9]

Materials:

- **Atalafoline**
- Poly(lactic-co-glycolic acid) (PLGA)
- Folic acid-conjugated PLGA (FA-PLGA)
- Polyvinyl alcohol (PVA)
- Dichloromethane (DCM)
- Deionized water

Procedure:

- Dissolve 10 mg of **Atalafoline**, 80 mg of PLGA, and 20 mg of FA-PLGA in 2 mL of DCM. This forms the organic phase.
- Prepare a 2% (w/v) PVA solution in deionized water. This is the aqueous phase.
- Add the organic phase to 10 mL of the aqueous phase.
- Emulsify the mixture by sonication for 2 minutes on an ice bath.
- Stir the resulting emulsion at room temperature for 4 hours to allow for solvent evaporation and nanoparticle formation.
- Collect the nanoparticles by centrifugation at 15,000 rpm for 20 minutes at 4°C.
- Wash the nanoparticle pellet three times with deionized water to remove excess PVA.
- Resuspend the final nanoparticle pellet in deionized water and lyophilize for storage.

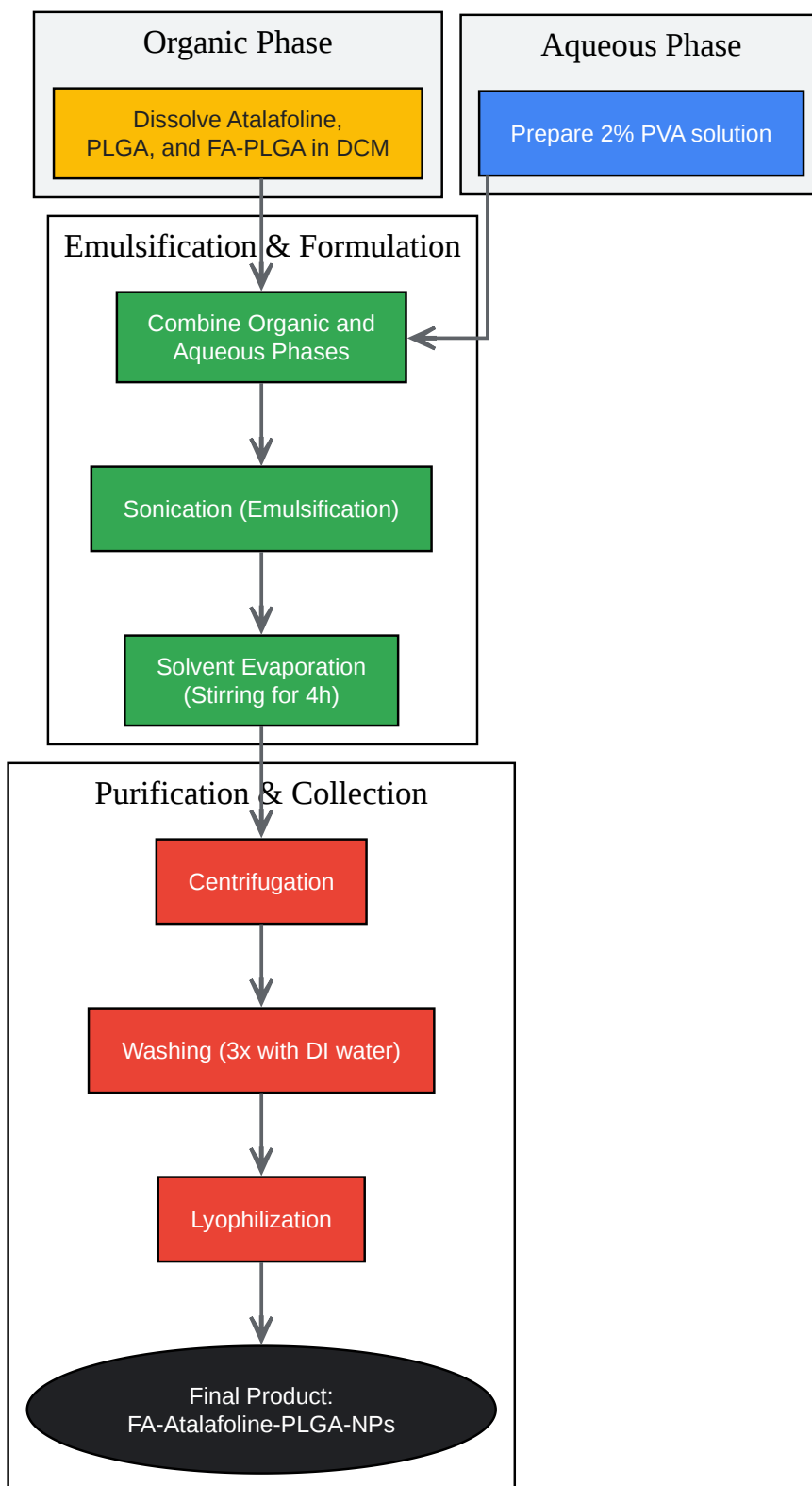

[Click to download full resolution via product page](#)

Caption: Workflow for the formulation of FA-**Atalafoline**-PLGA-NPs.

## Protocol 2: In Vitro Cytotoxicity Assessment using MTT Assay

This protocol details the determination of the cytotoxic effects of **Atalafoline** and its nanoformulations on cancer cells.[\[10\]](#)[\[11\]](#)

Materials:

- MCF-7 breast cancer cells
- DMEM supplemented with 10% FBS and 1% penicillin-streptomycin
- Free **Atalafoline**, **Atalafoline**-PLGA-NPs, and FA-**Atalafoline**-PLGA-NPs
- MTT (3-(4,5-dimethylthiazol-2-yl)-2,5-diphenyltetrazolium bromide) solution (5 mg/mL in PBS)
- Dimethyl sulfoxide (DMSO)
- 96-well plates

Procedure:

- Seed MCF-7 cells in a 96-well plate at a density of  $5 \times 10^3$  cells per well and incubate for 24 hours at 37°C in a 5% CO<sub>2</sub> atmosphere.
- Prepare serial dilutions of the free drug and nanoformulations in the cell culture medium.
- Replace the medium in the wells with 100 µL of the prepared drug dilutions. Include wells with untreated cells as a control.
- Incubate the plates for 24, 48, or 72 hours.
- After the incubation period, add 10 µL of MTT solution to each well and incubate for an additional 4 hours.
- Carefully remove the medium and add 100 µL of DMSO to each well to dissolve the formazan crystals.

- Measure the absorbance at 570 nm using a microplate reader.
- Calculate cell viability as a percentage of the untreated control and determine the IC<sub>50</sub> values.

## Protocol 3: Cellular Uptake Study by Flow Cytometry

This protocol is for quantifying the cellular uptake of fluorescently labeled nanoparticles.

Materials:

- Fluorescently labeled FA-**Atalafoline**-PLGA-NPs (e.g., encapsulating Coumarin-6)
- MCF-7 cells
- Folic acid solution (for competition assay)
- PBS
- Trypsin-EDTA
- Flow cytometer

Procedure:

- Seed MCF-7 cells in a 6-well plate and grow to 80-90% confluency.
- For the competition assay, pre-incubate a set of wells with a high concentration of free folic acid for 1 hour to block folate receptors.
- Treat the cells with the fluorescently labeled nanoparticles (and the control nanoparticles) for 4 hours.
- Wash the cells three times with cold PBS to remove non-internalized nanoparticles.
- Harvest the cells using Trypsin-EDTA and resuspend them in PBS.
- Analyze the cell suspension using a flow cytometer to measure the fluorescence intensity, which corresponds to the amount of nanoparticle uptake.

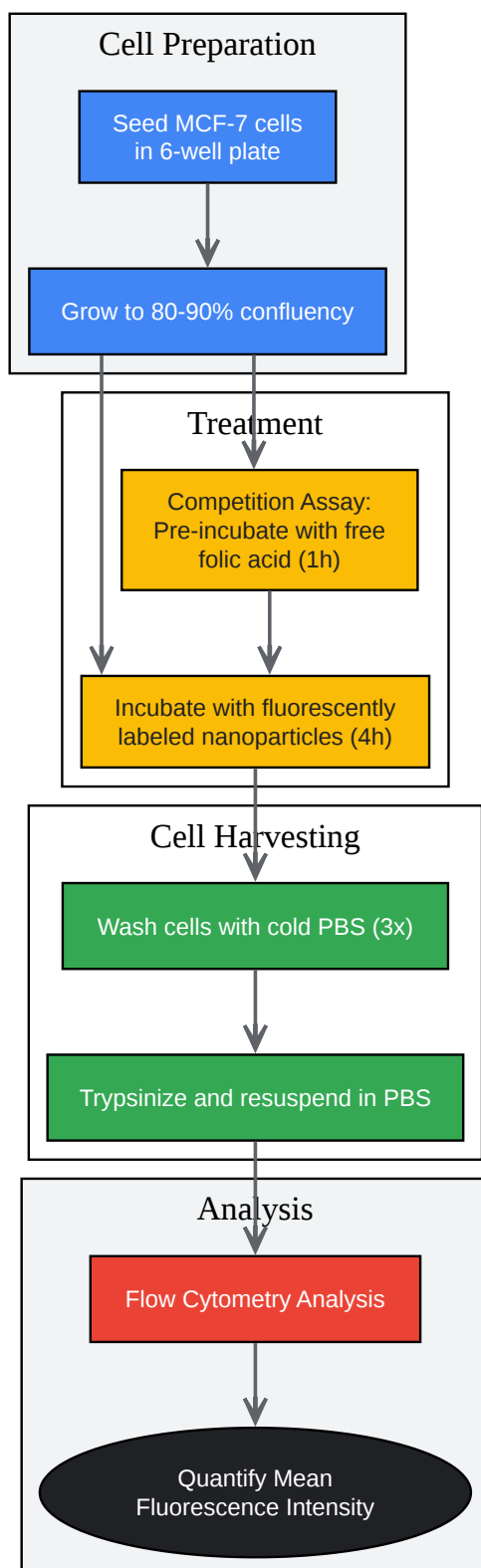

[Click to download full resolution via product page](#)

Caption: Workflow for quantifying cellular uptake via flow cytometry.



## Biocompatibility

Preliminary biocompatibility studies are essential for any novel drug delivery system.[12][13][14][15] In vitro cytotoxicity assays against normal cell lines (e.g., fibroblasts) and hemolysis assays should be conducted to assess the safety of the **Atalafoline** nanoformulations. In vivo studies should monitor for any signs of toxicity or inflammatory response.[15]

## Conclusion

**Atalafoline**, when formulated into targeted nanoparticles, presents a promising strategy for enhancing the efficacy of cancer therapy. The protocols and data provided herein offer a foundational framework for researchers to further explore the potential of this novel compound in targeted drug delivery applications. Further studies should focus on in vivo efficacy, pharmacokinetic profiling, and comprehensive toxicity assessments.

### *Need Custom Synthesis?*

*BenchChem offers custom synthesis for rare earth carbides and specific isotopic labeling.*

*Email: [info@benchchem.com](mailto:info@benchchem.com) or [Request Quote Online](#).*

## References

1. Synthesis of new quinoline derivatives as inhibitors of human tumor cells growth - PubMed [pubmed.ncbi.nlm.nih.gov]
2. Design, synthesis, and docking study of new quinoline derivatives as antitumor agents - PubMed [pubmed.ncbi.nlm.nih.gov]
3. A Novel Folic Acid Receptor-Targeted Drug Delivery System Based on Curcumin-Loaded  $\beta$ -Cyclodextrin Nanoparticles for Cancer Treatment - PubMed [pubmed.ncbi.nlm.nih.gov]
4. A Novel Folic Acid Receptor-Targeted Drug Delivery System Based on Curcumin-Loaded  $\beta$ -Cyclodextrin Nanoparticles for Cancer Treatment - PMC [pmc.ncbi.nlm.nih.gov]
5. Formulation and Characterization of Nanomedicine (Solid Lipid Nanoparticle) Associate with the Extract of Pterospermum acerifolium for the Screening of Neurochemicals and Neuroendocrine Effects - PMC [pmc.ncbi.nlm.nih.gov]
6. Chemistry and Art of Developing Lipid Nanoparticles for Biologics Delivery: Focus on Development and Scale-Up - PMC [pmc.ncbi.nlm.nih.gov]

- 7. Intranasal agomelatine solid lipid nanoparticles to enhance brain delivery: formulation, optimization and in vivo pharmacokinetics - PMC [pmc.ncbi.nlm.nih.gov]
- 8. NRF2 Regulates HER1 Signaling Pathway to Modulate the Sensitivity of Ovarian Cancer Cells to Lapatinib and Erlotinib - PubMed [pubmed.ncbi.nlm.nih.gov]
- 9. Nanoparticle formulation of ormeloxifene for pancreatic cancer - PubMed [pubmed.ncbi.nlm.nih.gov]
- 10. Cell Viability Assays - Assay Guidance Manual - NCBI Bookshelf [ncbi.nlm.nih.gov]
- 11. m.youtube.com [m.youtube.com]
- 12. A Review of the Biocompatibility of Implantable Devices: Current Challenges to Overcome Foreign Body Response - PMC [pmc.ncbi.nlm.nih.gov]
- 13. End of Life Biocompatibility Assessment for Chronically Implanted Cardiac Leads - PubMed [pubmed.ncbi.nlm.nih.gov]
- 14. mdpi.com [mdpi.com]
- 15. In Vivo Evaluation of Biodegradability and Biocompatibility of Fe30Mn Alloy - PubMed [pubmed.ncbi.nlm.nih.gov]
- To cite this document: BenchChem. [Application Notes & Protocols: Atalafoline for Targeted Drug Delivery Research]. BenchChem, [2025]. [Online PDF]. Available at: [https://www.benchchem.com/product/b011924#atalafoline-for-targeted-drug-delivery-research]

---

### Disclaimer & Data Validity:

The information provided in this document is for Research Use Only (RUO) and is strictly not intended for diagnostic or therapeutic procedures. While BenchChem strives to provide accurate protocols, we make no warranties, express or implied, regarding the fitness of this product for every specific experimental setup.

**Technical Support:** The protocols provided are for reference purposes. Unsure if this reagent suits your experiment? [[Contact our Ph.D. Support Team for a compatibility check](#)]

**Need Industrial/Bulk Grade?** [Request Custom Synthesis Quote](#)

# BenchChem

Our mission is to be the trusted global source of essential and advanced chemicals, empowering scientists and researchers to drive progress in science and industry.

## Contact

Address: 3281 E Guasti Rd

Ontario, CA 91761, United States

Phone: (601) 213-4426

Email: [info@benchchem.com](mailto:info@benchchem.com)