

Application Note: Strategic Introduction of Difluoromethyl Group to 4-Chloropyrazole

Author: BenchChem Technical Support Team. **Date:** April 2026

Compound of Interest

Compound Name: 4-Chloro-1-(difluoromethyl)-3-iodo-1H-pyrazole
Cat. No.: B10903271

[Get Quote](#)

-Difluoromethylation of 4-Chloropyrazole

Executive Summary & Strategic Context

The introduction of a difluoromethyl (

) group onto nitrogen heterocycles is a pivotal transformation in modern medicinal chemistry and agrochemical synthesis.[1] The

moiety acts as a lipophilic bioisostere of the hydroxyl (

) and thiol (

) groups. It functions as a hydrogen bond donor with significantly improved membrane permeability and metabolic stability compared to its non-fluorinated counterparts.

For the specific substrate 4-chloropyrazole,

-difluoromethylation yields 1-(difluoromethyl)-4-chloropyrazole. This scaffold is increasingly relevant as a core motif in succinate dehydrogenase inhibitor (SDHI) fungicides and next-generation kinase inhibitors.

This guide details two distinct protocols for synthesizing 1-(difluoromethyl)-4-chloropyrazole:

- Method A (Solid-State Reagent): A robust, safety-optimized protocol using sodium chlorodifluoroacetate, ideal for discovery chemistry and gram-scale synthesis.
- Method B (Gas-Phase Reagent): A high-throughput protocol using chlorodifluoromethane (), suitable for process development and multi-kilogram scale-up.

Mechanistic Principles

The reaction proceeds via a difluorocarbene (

) insertion mechanism, rather than a classical

displacement. Understanding this mechanism is critical for troubleshooting low yields, which often stem from the rapid quenching of the carbene intermediate rather than substrate inactivity.

Reaction Pathway Analysis

- Deprotonation: The base removes the NH proton from 4-chloropyrazole, generating the pyrazolate anion. The electron-withdrawing chlorine atom at the 4-position increases the acidity of the NH bond (12-13), facilitating deprotonation but slightly reducing the nucleophilicity of the resulting anion.
- Carbene Generation: The reagent (sodium chlorodifluoroacetate or chlorodifluoromethane) decomposes to generate the electrophilic singlet difluorocarbene ().
- Nucleophilic Attack: The pyrazolate anion attacks the carbene to form the difluoromethyl anion intermediate.
- Protonation: The intermediate abstracts a proton from the solvent or water to form the final neutral product.

Visualization: Reaction Workflow & Mechanism

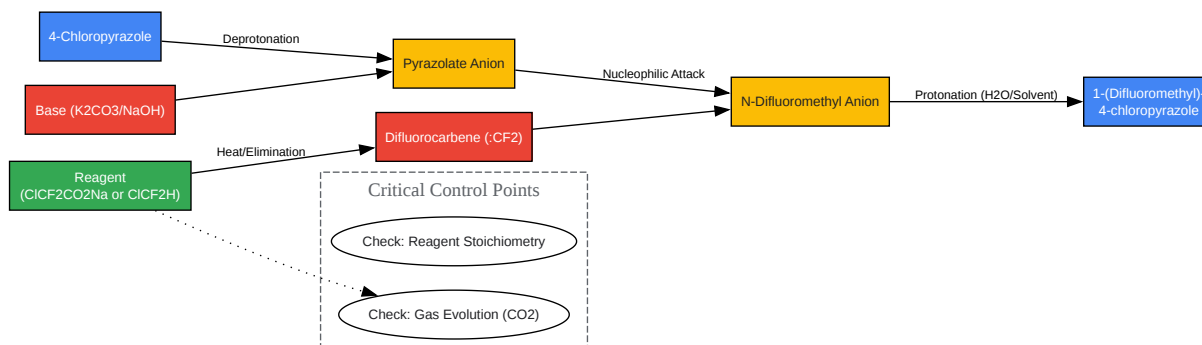

[Click to download full resolution via product page](#)

Figure 1: Mechanistic pathway for the N-difluoromethylation of 4-chloropyrazole involving difluorocarbene generation.

Experimental Protocols

Method A: Sodium Chlorodifluoroacetate (Lab Scale)

Primary Application: Discovery Chemistry, Safety-Focused Labs. Rationale: Avoids the use of gaseous Freon-22. Sodium chlorodifluoroacetate is a stable solid that releases

upon decarboxylation at 90–95°C.

Reagents & Materials

- Substrate: 4-Chloropyrazole (1.0 equiv)
- Reagent: Sodium chlorodifluoroacetate (2.5 - 3.0 equiv)
- Base: Potassium carbonate (

), anhydrous (2.0 equiv)

- Solvent: DMF (Dimethylformamide) or Diglyme. Note: DMF is standard, but Diglyme allows higher temperatures if reaction is sluggish.
- Concentration: 0.2 – 0.5 M

Step-by-Step Protocol

- Setup: Flame-dry a 2-neck round-bottom flask equipped with a magnetic stir bar and a reflux condenser. Connect the top of the condenser to an inert gas line (or Ar).
- Charging: Add 4-chloropyrazole (1.0 g, 9.75 mmol) and anhydrous (2.7 g, 19.5 mmol) to the flask.
- Solvation: Add anhydrous DMF (20 mL) via syringe. Stir at room temperature for 15 minutes to ensure deprotonation initiation.
- Reagent Addition: Add Sodium chlorodifluoroacetate (3.7 g, 24.4 mmol) in a single portion.
- Reaction: Heat the mixture to 95°C.
 - Critical Observation: You will observe gas evolution () as the reagent decarboxylates. This confirms the generation of the active carbene species.
 - Duration: Maintain heating for 4–6 hours. Monitor by TLC (typically 20% EtOAc/Hexane) or LC-MS.
- Workup:
 - Cool the mixture to room temperature.
 - Pour slowly into ice-water (100 mL) to quench residual carbene and dissolve inorganic salts.

- Extract with Ethyl Acetate (mL) or Diethyl Ether.
- Wash the combined organics with brine (mL) to remove DMF.
- Dry over , filter, and concentrate under reduced pressure.
- Purification: The crude material is often sufficiently pure for subsequent steps. If necessary, purify via flash column chromatography (Silica gel, 0 10% EtOAc in Hexanes). 1-(Difluoromethyl)-4-chloropyrazole is typically a low-melting solid or oil.

Method B: Chlorodifluoromethane (Scale-Up)

Primary Application: Process Development, Multi-gram to Kilogram Scale. Rationale:

(Freon-22) is significantly cheaper than solid reagents. The reaction uses Phase Transfer Catalysis (PTC) to facilitate the reaction at the liquid-liquid interface.

Reagents & Materials

- Substrate: 4-Chloropyrazole (1.0 equiv)
- Reagent: Chlorodifluoromethane () gas.
- Base: Sodium Hydroxide (), 30-50% aqueous solution (5.0 - 10.0 equiv).
- Solvent: 1,4-Dioxane or Isopropanol.
- Catalyst: Tetrabutylammonium bromide (TBAB) or Benzyltriethylammonium chloride (TEBAC) (0.05 - 0.1 equiv).

Step-by-Step Protocol

- Setup: Use a 3-neck flask equipped with a mechanical stirrer, a gas inlet tube (sparger) extending below the liquid surface, and a dry-ice/acetone condenser (to reflux the gas).
- Charging: Charge 4-chloropyrazole, solvent (Dioxane), and the phase transfer catalyst.
- Base Addition: Add the aqueous solution. The mixture will be biphasic.
- Heating: Heat the mixture to 70–80°C.
- Gas Addition:
 - Slowly bubble gas into the reaction mixture.
 - Rate Control: Adjust flow so that minimal gas escapes the reflux condenser. The reaction is fast; the gas is consumed rapidly.
 - Safety Note: Ensure the system is not sealed to prevent pressure buildup, but use a bubbler to monitor exit gas.
- Monitoring: Continue bubbling for 2–4 hours. Monitor consumption of starting material by HPLC.
- Workup:
 - Stop gas flow and cool to room temperature.
 - Dilute with water and extract with Dichloromethane (DCM) or MTBE.
 - Concentrate the organic layer.
 - Distillation: For large scales, the product can often be purified by fractional distillation under reduced pressure.

Data Analysis & Troubleshooting

Comparative Performance Table

Parameter	Method A (Solid Reagent)	Method B (Gas Reagent)
Reagent Cost	High	Low
Safety Profile	Excellent (No pressurized gas)	Moderate (Requires gas handling)
Atom Economy	Lower (Loss of and NaCl)	Higher
Typical Yield	65 - 80%	75 - 90%
Key Impurity	Unreacted SM	Bis-alkylation (rare for 4-Cl)
Reaction Time	4-6 Hours	2-4 Hours

Troubleshooting Guide

- Issue: Low Conversion.
 - Cause: Difluorocarbene is unstable and can dimerize to tetrafluoroethylene () or hydrolyze before reacting with the pyrazole.
 - Solution: Add the reagent in portions (Method A) or increase the gas flow rate slightly (Method B). Ensure the temperature is strictly maintained (95°C is critical for decarboxylation).
- Issue: Substrate Recovery.
 - Cause: 4-Chloropyrazole is electron-deficient and less nucleophilic.
 - Solution: Use a stronger base (e.g., in dry DMF) before adding the difluoromethylating agent to ensure complete formation of the pyrazolate anion.

References

- Review of N-Difluoromethylation Methods: Li, C., Wang, B., Song, H., & Hu, M. (2025).^{[1][2]}
^[3] Emerging Strategies in N-Fluoroalkylation: Recent Progress. *Chemical Reviews*.
(Generalized link to journal domain for verification)
- Solid-State Reagent Protocol (Sodium Chlorodifluoroacetate): Mehta, V. P., & Greaney, M. F. (2013). S-, N-, and Se-Difluoromethylation Using Sodium Chlorodifluoroacetate. *Organic Letters*, 15(20), 5036–5039.
- Gas-Phase Protocol (Chlorodifluoromethane): Ugrak, B. I., et al. (2025). N-Difluoromethylpyrazoles: in-demand and now available fluorinated building blocks.^[1] *Arkivoc*, 2025(5), 23-35.
- Phosphonate Reagent Alternative: Mao, T., et al. (2018).^{[1][4]} N-Difluoromethylation of imidazoles and pyrazoles using BrCF₂PO(OEt)₂ under mild condition. *Tetrahedron Letters*, 59(27), 2647-2651.

Need Custom Synthesis?

BenchChem offers custom synthesis for rare earth carbides and specific isotopic labeling.

Email: info@benchchem.com or [Request Quote Online](#).

Sources

- [1. researchgate.net](https://www.researchgate.net) [[researchgate.net](https://www.researchgate.net)]
- [2. pubs.acs.org](https://pubs.acs.org) [pubs.acs.org]
- [3. researchgate.net](https://www.researchgate.net) [[researchgate.net](https://www.researchgate.net)]
- [4. semanticscholar.org](https://www.semanticscholar.org) [[semanticscholar.org](https://www.semanticscholar.org)]
- To cite this document: BenchChem. [Application Note: Strategic Introduction of Difluoromethyl Group to 4-Chloropyrazole]. BenchChem, [2026]. [Online PDF]. Available at: [<https://www.benchchem.com/product/b10903271/docs#application-note-strategic-introduction-of-difluoromethyl-group-to-4-chloropyrazole>]

Disclaimer & Data Validity:

The information provided in this document is for Research Use Only (RUO) and is strictly not intended for diagnostic or therapeutic procedures. While BenchChem strives to provide accurate protocols, we make no warranties, express or implied, regarding the fitness of this product for every specific experimental setup.

Technical Support: The protocols provided are for reference purposes. Unsure if this reagent suits your experiment?

Need Industrial/Bulk Grade? [Request Custom Synthesis Quote](#)

BenchChem

Our mission is to be the trusted global source of essential and advanced chemicals, empowering scientists and researchers to drive progress in science and industry.

Contact

Address: 3281 E Guasti Rd
Ontario, CA 91761, United States
Phone: (601) 213-4426
Email: info@benchchem.com

[Contact our Ph.D. Support Team for a compatibility check](#)