

Technical Support Center: Catalyst Selection for 4-Nitroheptanedial Synthesis

Author: BenchChem Technical Support Team. **Date:** April 2026

Compound of Interest

Compound Name: 4-Nitroheptanedial

CAS No.: 147189-43-3

Cat. No.: B109749

[Get Quote](#)

Welcome to the technical support center for the synthesis of **4-Nitroheptanedial**. This guide is designed for researchers, scientists, and drug development professionals to provide in-depth technical guidance, troubleshooting protocols, and answers to frequently asked questions regarding the catalytic synthesis of this important γ -nitroaldehyde.

The most plausible and efficient route to **4-Nitroheptanedial** is the double Michael addition of nitromethane to acrolein. This reaction, while powerful, is sensitive to catalyst choice and reaction conditions, which can significantly impact yield and purity. This document provides a comprehensive overview of catalyst selection and reaction optimization to address challenges you may encounter.

Frequently Asked Questions (FAQs)

Q1: What is the most common synthetic strategy for **4-Nitroheptanedial**, and why is catalyst selection so critical?

A1: The most direct and common strategy is the base-catalyzed double Michael addition (or conjugate addition) of nitromethane to two equivalents of acrolein. In this reaction, a catalyst

deprotonates nitromethane to form a nitronate anion. This anion then acts as a nucleophile, attacking the β -carbon of the α,β -unsaturated aldehyde, acrolein. This process occurs twice to form the seven-carbon dialdehyde backbone with a nitro group at the 4-position.

Catalyst selection is critical for several reasons:

- **Acidity of Nitromethane:** The protons on the carbon adjacent to the nitro group are acidic enough to be removed by a base, but the choice of base determines the concentration of the reactive nitronate anion.[1]
- **Acrolein Polymerization:** Acrolein is highly susceptible to polymerization under basic conditions. A catalyst that is too strong or used in high concentration can lead to significant polymer formation, drastically reducing the yield of the desired product.[2]
- **Reaction Rate and Selectivity:** The catalyst influences the rate of the Michael addition versus competing side reactions. An optimal catalyst will promote the desired C-C bond formation efficiently while minimizing side product formation.
- **Mild Conditions:** The powerful electron-withdrawing nature of the nitro group allows for the use of very mild bases, which helps to avoid unwanted side reactions involving the aldehyde functional groups.[1]

Q2: What are the main classes of catalysts used for the synthesis of γ -nitroaldehydes like 4-Nitroheptanedial?

A2: There are three main classes of catalysts employed for this type of transformation:

- **Base Catalysts:** These are the most common and include inorganic bases (e.g., NaOH, KOH, K_2CO_3) and organic bases (e.g., DBU, triethylamine).[3][4][5][6] Mild bases are often preferred to prevent side reactions.[1]
- **Organocatalysts:** These are small organic molecules that can catalyze the reaction, often with high enantioselectivity if a chiral catalyst is used. Proline and its derivatives, as well as certain peptides and chiral amines, are effective for the conjugate addition of aldehydes or nitroalkanes.[7][8][9][10][11][12] They typically operate through enamine or iminium ion intermediates.[13][14][15]

- Phase-Transfer Catalysts (PTCs): These are particularly useful when using a biphasic reaction system (e.g., an aqueous base and an organic solvent). Catalysts like quaternary ammonium salts (e.g., tetrabutylammonium chloride, TBAC) facilitate the transfer of the nitronate anion from the aqueous phase to the organic phase where the reaction with acrolein occurs.^{[2][16][17]} This can improve yields by bringing the reactants together while maintaining a low concentration of base in the organic phase.^{[2][17]}

Q3: I am observing a significant amount of a polymeric, insoluble material in my reaction flask. What is causing this and how can I prevent it?

A3: The formation of a polymeric substance is a very common issue and is almost certainly due to the polymerization of acrolein.^[2] This is typically initiated by a base that is too strong or a localized high concentration of base.

To prevent this:

- Use a Milder Base: Switch from strong bases like NaOH or KOH to milder options like triethylamine, DBU, or even heterogeneous catalysts like basic alumina.^[1]
- Control Temperature: Polymerization is often exothermic. Running the reaction at a lower temperature (e.g., 0 °C or even lower) can significantly reduce the rate of polymerization.^[18]
- Slow Addition of Acrolein: Instead of adding all the acrolein at once, add it slowly to the mixture of nitromethane and catalyst using a syringe pump. This keeps the instantaneous concentration of the acceptor low, favoring the desired bimolecular reaction over polymerization.^[2]
- Consider a Phase-Transfer Catalyst: Using a PTC in a biphasic system can be very effective at minimizing polymerization.^{[2][17]}

Q4: My final product is a ketone instead of an aldehyde. What happened?

A4: You have likely encountered a subsequent reaction known as the Nef reaction.^[2] The initial Michael adduct is a nitro compound, which exists in equilibrium with its nitronate salt form under basic conditions. If the reaction is worked up using a strong acid (typically pH < 1), the nitronate is hydrolyzed to a carbonyl group.^{[2][19][20][21]} Since your target molecule is a primary nitroalkane derivative, this would convert the nitro group into an aldehyde, but if the

starting nitroalkane were secondary, it would form a ketone. It's also possible that one of the existing aldehyde groups was involved in an intramolecular cyclization followed by rearrangement.

To avoid the Nef reaction:

- Use a Neutral or Mildly Acidic Quench: When the reaction is complete, quench it with a saturated aqueous solution of NH_4Cl or a dilute buffer solution instead of a strong acid.
- Careful pH Control: Ensure the pH of your workup and purification steps does not drop to strongly acidic levels.

Troubleshooting Guide

Problem	Potential Cause(s)	Recommended Solution(s)
Low or No Yield	<p>1. Catalyst Ineffective: The chosen base may be too weak to deprotonate nitromethane sufficiently. 2. Poor Solubility: Reactants and catalyst may not be adequately dissolved in the chosen solvent. 3. Reaction Temperature Too Low: Insufficient thermal energy to overcome the activation barrier.[18] 4. Retro-Michael Reaction: The reaction is reversible and the equilibrium may not favor the product.[2]</p>	<p>1. Catalyst Screening: Try a slightly stronger base or a different class of catalyst (e.g., organocatalyst). 2. Solvent Optimization: Switch to a solvent that provides better solubility for all components. Polar aprotic solvents are often a good choice. For biphasic systems, ensure vigorous stirring.[17] 3. Temperature Adjustment: Gradually increase the reaction temperature, but monitor closely for acrolein polymerization. 4. Product Trapping: In some cases, converting the product in situ to a more stable derivative can shift the equilibrium.</p>
Formation of Multiple Side Products	<p>1. Poly-addition Products: The initial Michael adduct can react again if it still has acidic protons.[2] 2. Henry Reaction (Nitroaldol): Nitromethane can react with the aldehyde group of acrolein (1,2-addition) instead of the double bond.[2] 3. Acrolein Self-Condensation: Acrolein can undergo aldol-type reactions with itself. 4. Oxidation of Aldehydes: The aldehyde groups can be sensitive to oxidation, especially during workup.</p>	<p>1. Stoichiometry Control: Use a slight excess of nitromethane to favor the double addition product. 2. Catalyst Choice: Use catalysts known to favor conjugate addition. Lewis acidic conditions can sometimes favor 1,4-addition. 3. Low Temperature & Slow Addition: As with polymerization, keeping the temperature and acrolein concentration low minimizes self-condensation.[18] 4. Inert Atmosphere & Careful Workup:</p>

Run the reaction under an inert atmosphere (N₂ or Ar). During workup, avoid exposure to strong oxidizing agents or prolonged exposure to air.

Product Decomposes During Purification	<p>1. Instability on Silica Gel: Nitroaldehydes can be sensitive to the acidic nature of standard silica gel, leading to dehydration or other side reactions.[22] 2. Thermal Instability: The product may be unstable at the temperatures used for solvent evaporation or distillation.</p>	<p>1. Neutralize Silica Gel: Pre-treat the silica gel with a base (e.g., wash with a triethylamine/hexane mixture) before performing column chromatography. Alternatively, use a different stationary phase like alumina or Florisil. 2. Low-Temperature Purification: Use a rotary evaporator with a low-temperature water bath. Avoid high-vacuum distillation if possible. Recrystallization from a suitable solvent system is often a better alternative.[22]</p>
--	---	---

Difficulty in Product Isolation/Purification	<p>1. Oily Product: The product may be a viscous oil that is difficult to handle and crystallize.[22] 2. Contamination with Byproducts: Close-running spots on TLC can make chromatographic separation difficult.</p>	<p>1. Derivative Formation: Consider converting the crude aldehyde to a more crystalline derivative (e.g., a bisulfite adduct or an oxime) for purification, followed by regeneration of the aldehyde. 2. Recrystallization: Extensive screening of solvents and solvent mixtures may be required to find suitable conditions for crystallization. [22] 3. Alternative Purification: Techniques like preparative HPLC or centrifugal</p>
--	---	--

chromatography may be necessary for high purity.

Visualizing the Reaction Pathway

The synthesis of **4-Nitroheptanedial** via the double Michael addition of nitromethane to acrolein can be visualized as a two-step sequence initiated by a base catalyst.

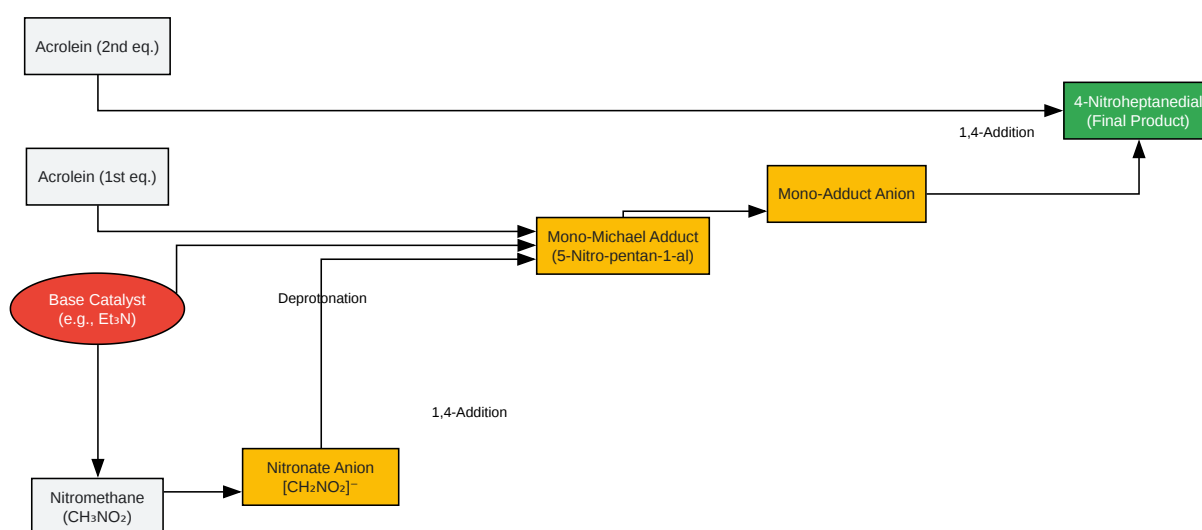

[Click to download full resolution via product page](#)

Caption: Catalytic cycle for the double Michael addition.

Experimental Protocols

Protocol 1: Phase-Transfer Catalyzed Synthesis

This protocol is adapted for minimizing the polymerization of acrolein by using a biphasic system.[2]

- **Setup:** To a 250 mL round-bottom flask equipped with a magnetic stirrer and an addition funnel, add nitromethane (1.0 eq) and dichloromethane (CH_2Cl_2).
- **Catalyst Addition:** Add a catalytic amount of tetrabutylammonium chloride (TBAC) (1-5 mol%).
- **Base Solution:** In a separate beaker, prepare a dilute aqueous solution of sodium hydroxide (e.g., 0.1 M). Add this to the reaction flask.
- **Acrolein Addition:** Add acrolein (2.1 eq) to the addition funnel, diluted with an equal volume of CH_2Cl_2 .
- **Reaction:** Begin vigorous stirring to ensure good mixing of the two phases. Add the acrolein solution dropwise over 2-3 hours at 0 °C (ice bath). Allow the reaction to stir for an additional 12-24 hours at room temperature, monitoring progress by TLC or GC.
- **Workup:** Once the reaction is complete, separate the organic layer. Wash the organic layer with a saturated solution of NH_4Cl , followed by brine.
- **Purification:** Dry the organic layer over anhydrous Na_2SO_4 , filter, and concentrate the solvent under reduced pressure. Purify the crude product by column chromatography on neutralized silica gel.

Protocol 2: Organocatalyzed Synthesis

This protocol uses a primary amino acid lithium salt as a catalyst, which can facilitate the reaction under mild conditions.^{[7][8]}

- **Catalyst Preparation:** In a dry 100 mL flask under an inert atmosphere (N_2), suspend the amino acid catalyst (e.g., O-tert-butyldiphenylsilyl L-tyrosine lithium salt, 0.1 eq) and anhydrous MgSO_4 (1.0 eq) in CH_2Cl_2 (1 mL per 0.5 mmol of aldehyde).
- **Reactant Addition:** To the catalyst slurry, add nitromethane (5.0 eq) followed by acrolein (2.0 eq) at room temperature. Note: For this specific synthesis, a stepwise addition of acrolein might be necessary to control the reaction.
- **Reaction:** Stir the mixture at room temperature for 48-72 hours. Monitor the reaction by TLC.

- **Workup:** Upon completion, quench the reaction with a saturated aqueous NH_4Cl solution. Extract the aqueous layer with CH_2Cl_2 (3x).
- **Purification:** Combine the organic layers, dry over anhydrous Na_2SO_4 , filter, and concentrate. Purify the residue by flash column chromatography.

Data Summary: Catalyst Performance

The choice of catalyst has a profound effect on the outcome of the Michael addition. The following table provides a qualitative summary of what to expect from different catalyst classes.

Catalyst Class	Typical Examples	Advantages	Disadvantages	Best For
Inorganic Bases	NaOH, K ₂ CO ₃ , Cs ₂ CO ₃	Inexpensive, readily available.	High risk of acrolein polymerization, can promote side reactions (Nef, Henry).[2]	Reactions where cost is the primary concern and optimization can mitigate side reactions.
Organic Bases	DBU, Triethylamine	Milder than inorganic bases, good solubility in organic solvents.	Can still cause polymerization if not used carefully, can be difficult to remove.	General purpose synthesis where mild conditions are needed to improve selectivity.
Organocatalysts	Proline derivatives, Chiral amines[8][10]	High selectivity, can provide asymmetric induction, mild reaction conditions.	Can be expensive, may require higher catalyst loading, longer reaction times.[10][11]	Asymmetric synthesis or when very high selectivity is required to avoid side products.
Phase-Transfer Catalysts	TBAC, Cinchona alkaloid derivatives[2][16]	Excellent for biphasic systems, minimizes polymerization by keeping base concentration low in the organic phase, often improves yield.[17]	Requires a two-phase system, vigorous stirring is essential.	Overcoming reactant solubility issues and significantly reducing polymerization of sensitive substrates like acrolein.

References

- Nitroalkanes are superb nucleophiles for conjug

- Hayashi, Y., et al. (2011). One-Pot Asymmetric Synthesis of γ -Nitroaldehydes from Aldehydes and Nitroalkanes through a Catalytic Tandem Reaction Using an Amino Acid Lithium Salt. *The Journal of Organic Chemistry*, 76(7), 2317-2320. [[Link](#)]
- Pandey, R., & Anand, R. V. (2018). Base-Catalyzed 1,6-Conjugate Addition of Nitroalkanes to p-Quinone Methides under Continuous Flow. *ACS Omega*, 3(10), 14331-14339. [[Link](#)]
- Pandey, R., & Anand, R. V. (2018). Base-Catalyzed 1,6-Conjugate Addition of Nitroalkanes to p-Quinone Methides under Continuous Flow. PMC. [[Link](#)]
- Pandey, R., & Anand, R. V. (2018). Base-Catalyzed 1,6-Conjugate Addition of Nitroalkanes to p-Quinone Methides under Continuous Flow. Semantic Scholar. [[Link](#)]
- Park, H. G., et al. (2001). Enantioselective Michael reaction of nitroalkanes and chalcones by phase-transfer catalysis using chiral quaternary ammonium salts. *Tetrahedron: Asymmetry*, 12(20), 2885-2889. [[Link](#)]
- Hayashi, Y., et al. (2011). One-Pot Asymmetric Synthesis of γ -Nitroaldehydes from Aldehydes and Nitroalkanes through a Catalytic Tandem Reaction Using an A. American Chemical Society.
- Alfa Chemistry. (n.d.). Nef Reaction. Alfa Chemistry.
- Wiesner, M., et al. (2008). Peptide Catalyzed Asymmetric Conjugate Addition Reactions of Aldehydes to Nitroethylene - A Convenient Entry into γ -Amino Acids. *Organic Chemistry Portal*. [[Link](#)]
- Company, R. M. (2015). A General, Scalable, Organocatalytic Nitro-Michael Addition to Enones: Enantioselective Access to All-Carbon Quaternary Stereocenters. *Organic Letters*. [[Link](#)]
- Company, R. M. (2015).
- BenchChem. (n.d.). Overcoming low yields in the Michael addition with 2-Nitropentane. BenchChem.
- BenchChem. (n.d.).
- Marrades-Gumbau, A., & Carda, M. (2017). Recent Advances in Asymmetric Organocatalyzed Conjugate Additions to Nitroalkenes. *Molecules*, 22(6), 913. [[Link](#)]

- Wikipedia. (n.d.). Nef reaction. Wikipedia.
- BenchChem. (n.d.). Common side products in the Michael addition of nitroalkanes. BenchChem.
- Okuyama, K., et al. (2025). Development and Mechanistic Insights into Nef Reaction for Preparation of Aldehydes Using Singlet Oxygen. *Organic Letters*. [[Link](#)]
- Unknown. (n.d.).
- Organic Syntheses Procedure. (n.d.). o-NITROBENZALDEHYDE. *Organic Syntheses*.
- Organic Chemistry Portal. (n.d.). Nef Reaction. *Organic Chemistry Portal*.
- Palomo, C., & Oiarbide, M. (2011). Asymmetric Organocatalytic Synthesis of γ -Nitrocarbonyl Compounds Through Michael and Domino Reactions.
- van der Meer, J. Y., et al. (2019). Biocatalytic Asymmetric Michael Additions of Nitromethane to α,β -Unsaturated Aldehydes via Enzyme-bound Iminium Ion Intermediates. *PMC*. [[Link](#)]
- Taylor & Francis. (n.d.). Nef reaction – Knowledge and References. Taylor & Francis.
- BenchChem. (n.d.). Managing reaction temperature for selective Michael addition. BenchChem.
- Das, T., et al. (2020). Enantioselective double Michael-Henry reaction of acrolein, α , β -nitroolefins and 2-methylcyclopentane-1, 3-dione.
- Kanemasa, S., et al. (2002). Enantioselective Michael additions of nitromethane by a catalytic double activation method using chiral Lewis Acid and achiral amine catalysts. *PubMed*. [[Link](#)]
- Attanasi, O. A., et al. (2022). Asymmetric Phase Transfer Catalysed Michael Addition of γ -Butenolide and N-Boc-Pyrrolidone to 4-Nitro-5-styrylisoxazoles. *MDPI*. [[Link](#)]
- Unknown. (2017).
- Unknown. (2017). The Reaction Mechanism of Organocatalytic Michael Addition of Nitromethane to Cinnamaldehyde: A Case Study on Catalyst Regeneration and Solvent Effect.
- Buchler GmbH. (n.d.).
- Vanderbilt, B. M. (n.d.). Process for the purification of nitro aliphatic compounds.
- Organic Syntheses Procedure. (n.d.). p-NITROBENZALDEHYDE. *Organic Syntheses*.
- Reddit. (2024).

- Lin, D., et al. (2011). Protein modification by acrolein: Formation and stability of cysteine adducts. PMC. [[Link](#)]
- Stevens, J. F., & Maier, C. S. (2008). Acrolein: Sources, metabolism, and biomolecular interactions relevant to human health and disease. PMC. [[Link](#)]
- Li, Y., et al. (2023). Acrolein-Mediated Conversion of Lysine to Electrophilic Heterocycles for Protein Diversification and Toxicity Profiling. Journal of the American Chemical Society. [[Link](#)]
- Batool, S., et al. (2019). Covalent Modifiers: A Chemical Perspective on the Reactivity of α,β -Unsaturated Carbonyls with Thiols via Hetero-Michael Addition Reactions. PMC. [[Link](#)]
- Chakhmakhchyan, A. Z., et al. (2021). Recent Progress in the Synthesis of Drugs and Bioactive Molecules Incorporating Nitro(het)arene Core. PMC. [[Link](#)]
- Kádas, I., et al. (2000). Synthesis of 4-cyano- and 4-nitrophenyl 2,5-anhydro- 1,6-dithio- α -D-gluco- and - α -L-guloseptanosides carrying different substituents at C-3 and C-4. PubMed. [[Link](#)]
- Unknown. (n.d.). Reactions of nitromethane and secondary nitroalkanes with arenes in polyphosphoric acid.
- Unknown. (n.d.). Enantioselective cascade double Michael addition of 3-nitro-2H-chromenes and acyclic enones: efficient synthesis of functionalized tricyclic chroman derivatives. Organic & Biomolecular Chemistry (RSC Publishing).
- Unknown. (n.d.). Asymmetric Michael addition reaction of acrolein, 3-nitro-2H-chromene,...
- Chemistry Steps. (2020). Michael Addition Reaction Mechanism. Chemistry Steps.
- Carocci, A., et al. (2022). Synthesis, Chiral Resolution and Enantiomers Absolute Configuration of 4-Nitropropranolol and 7-Nitropropranolol. MDPI. [[Link](#)]
- Unknown. (n.d.). Synthesis of 4- and 6-Substituted Nitroindoles.

Need Custom Synthesis?

BenchChem offers custom synthesis for rare earth carbides and specific isotopic labeling.

Email: info@benchchem.com or [Request Quote Online](#).

Sources

- [1. Nitroalkanes are superb nucleophiles for conjugate addition \[ns1.almerja.com\]](#)
- [2. pdf.benchchem.com \[pdf.benchchem.com\]](#)
- [3. pubs.acs.org \[pubs.acs.org\]](#)
- [4. Base-Catalyzed 1,6-Conjugate Addition of Nitroalkanes to p-Quinone Methides under Continuous Flow - PMC \[pmc.ncbi.nlm.nih.gov\]](#)
- [5. semanticscholar.org \[semanticscholar.org\]](#)
- [6. taylorandfrancis.com \[taylorandfrancis.com\]](#)
- [7. pubs.acs.org \[pubs.acs.org\]](#)
- [8. pubs.acs.org \[pubs.acs.org\]](#)
- [9. organic-chemistry.org \[organic-chemistry.org\]](#)
- [10. pubs.acs.org \[pubs.acs.org\]](#)
- [11. pubs.acs.org \[pubs.acs.org\]](#)
- [12. mdpi.com \[mdpi.com\]](#)
- [13. Biocatalytic Asymmetric Michael Additions of Nitromethane to \$\alpha,\beta\$ -Unsaturated Aldehydes via Enzyme-bound Iminium Ion Intermediates - PMC \[pmc.ncbi.nlm.nih.gov\]](#)
- [14. files01.core.ac.uk \[files01.core.ac.uk\]](#)
- [15. researchgate.net \[researchgate.net\]](#)
- [16. Redirecting \[linkinghub.elsevier.com\]](#)
- [17. pdf.benchchem.com \[pdf.benchchem.com\]](#)
- [18. pdf.benchchem.com \[pdf.benchchem.com\]](#)
- [19. alfa-chemistry.com \[alfa-chemistry.com\]](#)
- [20. Nef reaction - Wikipedia \[en.wikipedia.org\]](#)
- [21. Nef Reaction \[organic-chemistry.org\]](#)
- [22. reddit.com \[reddit.com\]](#)
- To cite this document: BenchChem. [Technical Support Center: Catalyst Selection for 4-Nitroheptanedial Synthesis]. BenchChem, [2026]. [Online PDF]. Available at: [\[https://www.benchchem.com/product/b109749/docs#technical-support-center-catalyst-selection-for-4-nitroheptanedial-synthesis\]](https://www.benchchem.com/product/b109749/docs#technical-support-center-catalyst-selection-for-4-nitroheptanedial-synthesis)

Disclaimer & Data Validity:

The information provided in this document is for Research Use Only (RUO) and is strictly not intended for diagnostic or therapeutic procedures. While BenchChem strives to provide accurate protocols, we make no warranties, express or implied, regarding the fitness of this product for every specific experimental setup.

Technical Support: The protocols provided are for reference purposes. Unsure if this reagent suits your experiment?

Need Industrial/Bulk Grade? [Request Custom Synthesis Quote](#)

BenchChem

Our mission is to be the trusted global source of essential and advanced chemicals, empowering scientists and researchers to drive progress in science and industry.

Contact

Address: 3281 E Guasti Rd
Ontario, CA 91761, United States
Phone: (601) 213-4426
Email: info@benchchem.com

[Contact our Ph.D. Support Team for a compatibility check](#)