

Validating NICE-01's On-Target Effects: A Comparison of Methodologies

Author: BenchChem Technical Support Team. **Date:** April 2026

Compound of Interest

Compound Name: NICE-01
Cat. No.: B10862022

[Get Quote](#)

A definitive guide for researchers on validating the mechanism of bifunctional molecules, comparing control-based approaches with genetic knockdown and knockout strategies.

The novel bifunctional molecule **NICE-01** (also known as AP1867-PEG2-JQ1) presents a powerful tool for cellular biologists, enabling the induced nuclear translocation of cytosolic proteins.[1] Its mechanism relies on the simultaneous binding of its two moieties to distinct targets: the JQ1 component engages with BET bromodomain proteins, primarily the nuclear-localized BRD4, while the AP1867 component binds to a user-defined cytosolic protein of interest (POI) tagged with a mutant FKBP (FKBPF36V).[1][2] This ternary complex formation effectively hijacks the nuclear localization of BRD4 to shuttle the tagged cytosolic protein into the nucleus.

Given the critical role of BRD4 in this process, rigorous validation of **NICE-01**'s on-target effects is paramount to ensure that the observed nuclear import is a direct consequence of BRD4 engagement and not an artifact of off-target interactions. This guide compares the validation methodologies employed in the seminal study of **NICE-01** with the gold-standard approaches of target knockout and knockdown, providing researchers with a comprehensive overview of the available techniques.

Comparison of On-Target Validation Strategies

While direct knockout or knockdown of BRD4 was not the primary validation method in the initial characterization of **NICE-01**, the study by Gibson et al. employed a series of robust control experiments to confirm its mechanism of action. In contrast, the broader field of BET inhibitor research, including studies on JQ1 (a key component of **NICE-01**), frequently utilizes genetic approaches like siRNA-mediated knockdown and CRISPR-Cas9-mediated knockout to validate on-target effects.

Validation Method	Principle	Key Advantages	Key Limitations
Control Compound Analysis (used for NICE-01)	The activity of the bifunctional molecule is compared to its individual, non-functional components or a competitive inhibitor.	- Directly tests the necessity of the bifunctional linkage. - Relatively straightforward to implement.	- Does not definitively rule out off-target effects of the intact bifunctional molecule. - Relies on the assumption that the individual components have no confounding activities.
siRNA-Mediated Knockdown of BRD4	Transiently reduces the expression of BRD4 by degrading its mRNA, thus preventing the synthesis of the target protein.	- High specificity for the target mRNA. - Allows for the study of essential genes where complete knockout might be lethal.	- Incomplete knockdown can lead to residual protein activity. - Potential for off-target effects of the siRNA itself.
CRISPR-Cas9 Mediated Knockout of BRD4	Permanently ablates the gene encoding BRD4, resulting in a complete and heritable loss of the target protein.	- Provides a true null background for the target protein. - Heritable modification allows for the creation of stable knockout cell lines.	- Potential for off-target gene editing. - Can be lethal if the target gene is essential for cell survival. - More technically demanding and time-consuming to generate knockout cell lines.

Quantitative Data Summary

The following tables summarize the quantitative data from representative experiments for each validation method.

Table 1: Validation of **NICE-01** using Control Compounds

Treatment	Concentration	Nuclear Localization of FKBP36V-mEGFP	Reference
NICE-01	250 nM	Enriched in the nucleus	[3]
JQ1-PEG2-NH2 + AP1867 (unlinked)	250 nM each	No nuclear enrichment	[3]
JQ1 (competitor)	10 μ M	Complemented (inhibited) NICE-01 effect	[3]

Table 2: Validation of JQ1 On-Target Effects using BRD4 Knockdown

Cell Line	Treatment	BRD4 Protein Level (relative to control)	c-Myc Protein Level (relative to control)	Reference
HEC-1A	BRD4 siRNA	Significantly Reduced	Significantly Reduced	[4]
Ishikawa	BRD4 siRNA	Significantly Reduced	Significantly Reduced	[4]
HEC-1A	JQ1 (1 μ M)	Significantly Reduced	Significantly Reduced	[4]
Ishikawa	JQ1 (1 μ M)	Significantly Reduced	Significantly Reduced	[4]

Table 3: Validation of On-Target Effects using BRD4 Knockout

Cell Line/Model	Genotype	Phenotype/Observation	Conclusion
Mouse Aorta Smooth Muscle	BRD4 Knockout	JQ1-induced inhibition of contraction is not replicated	Suggests off-target effect of JQ1 in this context
Human iPSC-derived Cardiomyocytes	BRD4 Knockout	Decreased cardiomyocyte differentiation	BRD4 is necessary for cardiomyocyte differentiation

Experimental Protocols

I. On-Target Validation of NICE-01 with Control Compounds

This protocol is based on the methods described by Gibson et al. for validating the bifunctional nature of **NICE-01**.

1. Cell Culture and Transfection:

- Culture 293T or U2OS cells in DMEM supplemented with 10% FBS and 1% penicillin/streptomycin.
- For visualization of nuclear import, co-transfect cells with plasmids encoding the cytosolic protein of interest fused to FKBP36V-mEGFP and a nuclear marker (e.g., mCherry-BRD4).

2. Compound Treatment:

- Prepare stock solutions of **NICE-01**, JQ1-PEG2-NH₂, and AP1867 in DMSO.
- Treat transfected cells with:
 - **NICE-01** (e.g., 250 nM).
 - A combination of JQ1-PEG2-NH₂ and AP1867 (e.g., 250 nM each).
 - DMSO as a vehicle control.

- For competition experiments, pre-treat cells with a high concentration of JQ1 (e.g., 10 μ M) before adding **NICE-01**.

3. Imaging and Analysis:

- Image the cells using fluorescence microscopy at various time points after treatment (e.g., 0, 20, 40, 60 minutes).
- Quantify the nuclear to cytosolic fluorescence ratio of the FKBP36V-mEGFP signal. A significant increase in this ratio in the **NICE-01** treated group compared to the control groups indicates on-target activity.

II. siRNA-Mediated Knockdown of BRD4 for JQ1

Validation

This protocol provides a general workflow for validating the on-target effects of JQ1 by knocking down its primary target, BRD4.

1. Cell Culture and siRNA Transfection:

- Seed cells (e.g., HEC-1A, Ishikawa) in a 6-well plate to reach 50-60% confluency at the time of transfection.
- Transfect cells with BRD4-specific siRNA or a non-targeting control siRNA using a lipid-based transfection reagent according to the manufacturer's instructions.

2. JQ1 Treatment:

- 48 hours post-transfection, treat the cells with JQ1 (e.g., 1 μ M) or DMSO for 24-48 hours.

3. Western Blot Analysis:

- Harvest cells and lyse to extract total protein.
- Separate proteins by SDS-PAGE and transfer to a PVDF membrane.
- Probe the membrane with primary antibodies against BRD4, a downstream target (e.g., c-Myc), and a loading control (e.g., β -actin).

- Incubate with HRP-conjugated secondary antibodies and visualize using an ECL substrate.
- Quantify band intensities to confirm BRD4 knockdown and assess the effect on downstream protein levels. The effect of JQ1 on c-Myc should be blunted in the BRD4 knockdown cells if the effect is on-target.

III. CRISPR-Cas9 Mediated Knockout of BRD4

This protocol outlines the steps for generating a BRD4 knockout cell line to serve as a negative control for validating on-target effects.

1. gRNA Design and Cloning:

- Design and clone two or more gRNAs targeting a critical exon of the BRD4 gene into a Cas9 expression vector.

2. Transfection and Clonal Selection:

- Transfect the host cell line with the Cas9/gRNA plasmids.
- Select for transfected cells using an appropriate marker (e.g., puromycin).
- Isolate single-cell clones by limiting dilution or FACS.

3. Knockout Validation:

- Expand individual clones and screen for BRD4 knockout by:
 - Genomic DNA sequencing: To confirm the presence of indel mutations.
 - Western Blot: To confirm the absence of BRD4 protein.^{[5][6][7]}

4. On-Target Effect Validation:

- Treat the validated BRD4 knockout and wild-type parental cells with **NICE-01**.
- Assess the nuclear translocation of the FKBP36V-tagged protein of interest. The absence of nuclear translocation in the knockout cells would provide definitive evidence of BRD4-dependent on-target activity.

Visualizations

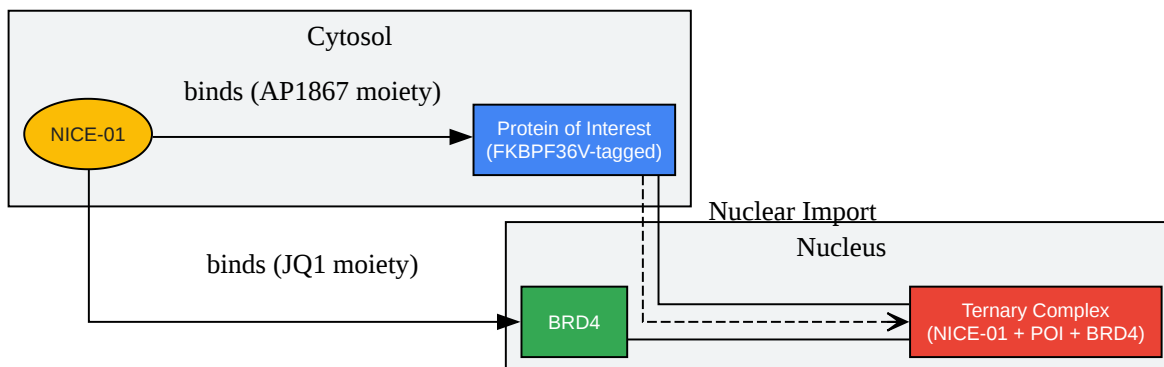

[Click to download full resolution via product page](#)

Caption: Signaling pathway of **NICE-01** induced nuclear import.

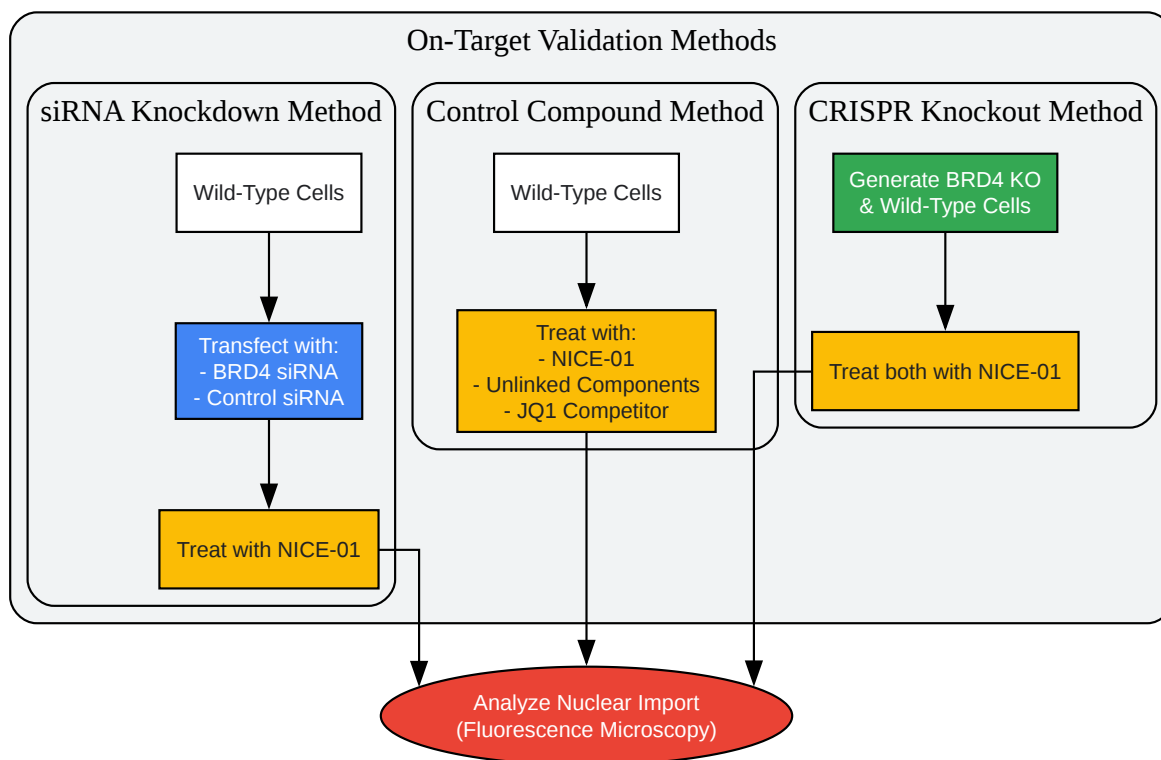

[Click to download full resolution via product page](#)

Caption: Experimental workflow for comparing validation methods.

Need Custom Synthesis?

BenchChem offers custom synthesis for rare earth carbides and specific isotopic labeling.

Email: info@benchchem.com or [Request Quote Online](#).

References

- 1. [biorxiv.org](https://www.biorxiv.org) [[biorxiv.org](https://www.biorxiv.org)]
- 2. pubs.acs.org [pubs.acs.org]
- 3. pdfs.semanticscholar.org [pdfs.semanticscholar.org]

- [4. researchgate.net \[researchgate.net\]](https://www.researchgate.net)
- [5. Overcoming the pitfalls of validating knockout cell lines by western blot \[horizondiscovery.com\]](https://www.horizondiscovery.com)
- [6. resources.revvity.com \[resources.revvity.com\]](https://www.resources.revvity.com)
- [7. Validate CRISPR-Edited Cells using Imaging and Western Blot Detection on a Microplate Reader \[moleculardevices.com\]](https://www.moleculardevices.com)
- To cite this document: BenchChem. [Validating NICE-01's On-Target Effects: A Comparison of Methodologies]. BenchChem, [2026]. [Online PDF]. Available at: [\[https://www.benchchem.com/product/b10862022/docs#validating-nice-01-s-on-target-effects-a-comparison-of-methodologies\]](https://www.benchchem.com/product/b10862022/docs#validating-nice-01-s-on-target-effects-a-comparison-of-methodologies)

Disclaimer & Data Validity:

The information provided in this document is for Research Use Only (RUO) and is strictly not intended for diagnostic or therapeutic procedures. While BenchChem strives to provide accurate protocols, we make no warranties, express or implied, regarding the fitness of this product for every specific experimental setup.

Technical Support: The protocols provided are for reference purposes. Unsure if this reagent suits your experiment?

Need Industrial/Bulk Grade? [Request Custom Synthesis Quote](#)

BenchChem

Our mission is to be the trusted global source of essential and advanced chemicals, empowering scientists and researchers to drive progress in science and industry.

Contact

Address: 3281 E Guasti Rd
Ontario, CA 91761, United States
Phone: (601) 213-4426
Email: info@benchchem.com

Contact our Ph.D. Support Team for a compatibility check