

Technical Support Center: GK13S Click Chemistry Reactions

Author: BenchChem Technical Support Team. **Date:** April 2026

Compound of Interest

Compound Name: GK13S
Cat. No.: B10862056

[Get Quote](#)

This technical support center provides researchers, scientists, and drug development professionals with a comprehensive guide to troubleshooting click chemistry reactions involving the alkyne-containing UCHL1 inhibitor, **GK13S**.

Frequently Asked Questions (FAQs)

Q1: What is **GK13S** and how is it used in click chemistry?

GK13S is a ligand and inhibitor of the deubiquitinase UCHL1.[1] It contains a terminal alkyne group, making it a valuable reagent for copper-catalyzed azide-alkyne cycloaddition (CuAAC) reactions, a cornerstone of click chemistry.[1][2] This allows for the covalent labeling and conjugation of **GK13S** to azide-modified molecules, such as proteins, nucleic acids, or fluorescent probes, to study its biological targets and mechanism of action.

Q2: What are the most common reasons for low or no product yield in a **GK13S** click chemistry reaction?

Low or no yield in a copper-catalyzed azide-alkyne cycloaddition (CuAAC) reaction involving **GK13S** can stem from several factors:

- **Catalyst Inactivity:** The active catalyst is Cu(I), which can be easily oxidized to the inactive Cu(II) state by dissolved oxygen.[3][4]
- **Poor Reagent Quality:** Degradation of the azide-containing reaction partner or impurities in solvents can inhibit the reaction.[3][4]
- **Substrate-Specific Issues:** Steric hindrance around the azide group on the binding partner can impede the reaction with **GK13S**.[3] Additionally, other functional groups on the azide-containing molecule might chelate the copper catalyst, rendering it inactive.[3]
- **Inappropriate Reaction Conditions:** Incorrect solvent, pH, temperature, or reactant concentrations can all lead to poor yields.[3]

Q3: What are the primary side reactions in **GK13S** click chemistry, and how can they be minimized?

The most common side reaction is the oxidative homocoupling of **GK13S** (Glaser coupling), where two molecules of **GK13S** react with each other.[3] This can be minimized by:

- **Maintaining Anaerobic Conditions:** Degassing solvents and running the reaction under an inert atmosphere (e.g., nitrogen or argon) can reduce oxygen levels.[5]
- **Using an Adequate Amount of Reducing Agent:** A sufficient concentration of a reducing agent like sodium ascorbate helps to keep the copper in the active Cu(I) state.
- **Utilizing a Copper-Stabilizing Ligand:** Ligands such as THPTA or BTAA can protect the Cu(I) catalyst from oxidation and disproportionation.[5][6]

Troubleshooting Guide

Low or No Product Yield

Potential Cause	Recommended Solution
Inactive Copper Catalyst	Ensure fresh sodium ascorbate solution is used to reduce Cu(II) to Cu(I). Degas all solvents and consider running the reaction under an inert atmosphere (nitrogen or argon).[5]
Poor Reagent Quality	Use high-purity, fresh reagents. If degradation of the azide partner is suspected, verify its integrity.
Suboptimal Reagent Concentrations	Optimize the concentrations of GK13S, the azide partner, copper sulfate, and sodium ascorbate. A typical starting point is a slight excess of the azide.[7]
Inhibitory Functional Groups	If the azide-containing molecule has groups that can chelate copper (e.g., thiols), consider using a copper-chelating ligand to protect the catalyst.[8]
Steric Hindrance	If steric hindrance is suspected, consider increasing the reaction time or temperature.[3] Alternatively, redesigning the linker on the azide partner to be longer and more flexible may be necessary.[9]
Incorrect pH	Ensure the reaction pH is within the optimal range of 4 to 12.[2][10]

Inconsistent or Poor Reproducibility

Potential Cause	Recommended Solution
Oxygen Contamination	Standardize the degassing procedure for all reactions. Capping reaction tubes can help minimize oxygen exposure.[5][11]
Variability in Reagent Preparation	Prepare fresh stock solutions of reagents, especially sodium ascorbate, for each set of experiments.[12][13]
Inconsistent Reaction Setup	Follow a consistent order of addition for all reagents. It is often recommended to pre-mix the copper salt and ligand before adding them to the reaction mixture.[5]

Experimental Protocols

General Protocol for **GK13S** Click Chemistry Reaction

This protocol provides a starting point and may require optimization for specific applications.

1. Prepare Stock Solutions:

- **GK13S**: Prepare a stock solution (e.g., 10 mM) in an appropriate solvent like DMSO.
- Azide-Containing Molecule: Prepare a stock solution in a compatible solvent.
- Copper(II) Sulfate (CuSO₄): Prepare a 20 mM stock solution in water.[5]
- Ligand (e.g., THPTA): Prepare a 50 mM stock solution in water.[5]
- Sodium Ascorbate: Prepare a 100 mM stock solution in water. This solution should always be prepared fresh.[5]

2. Reaction Setup:

- In a microcentrifuge tube, combine the azide-containing molecule and **GK13S** in a suitable buffer (e.g., phosphate buffer, pH 7.4).

- In a separate tube, premix the CuSO₄ and ligand solutions. A 1:5 copper-to-ligand ratio is common.[5][7]
- Add the copper/ligand mixture to the reaction tube containing the azide and **GK13S**.
- Initiate the reaction by adding the freshly prepared sodium ascorbate solution.
- Gently mix the reaction and allow it to proceed at room temperature. Reaction times can vary from minutes to several hours.[5]

3. Work-up and Purification:

- Upon completion, the method for purification will depend on the nature of the product. For biomolecules, techniques like size-exclusion chromatography or dialysis against a buffer containing EDTA can be used to remove the copper catalyst and unreacted reagents.[3] For small molecules, column chromatography may be appropriate.[3]

Reagent	Typical Final Concentration
GK13S (Alkyne)	10-100 μM
Azide Molecule	1.2 - 2 fold excess to alkyne[7]
Copper(II) Sulfate	50-250 μM[7]
Ligand (e.g., THPTA)	250-1250 μM (5-fold excess to copper)[7]
Sodium Ascorbate	5 mM[7]

Visualizations

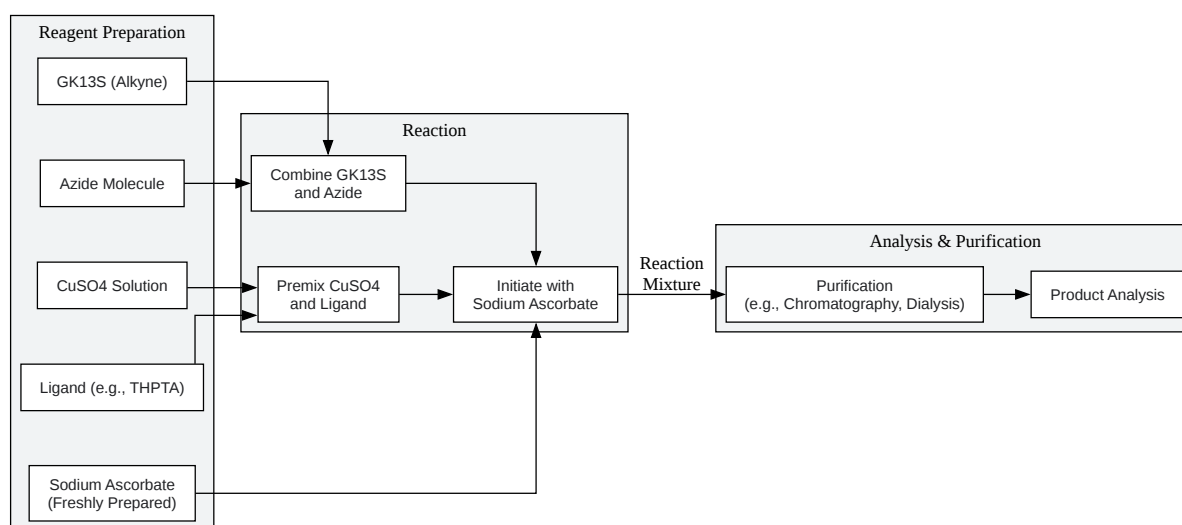

[Click to download full resolution via product page](#)

Caption: Experimental workflow for a **GK13S** click chemistry reaction.

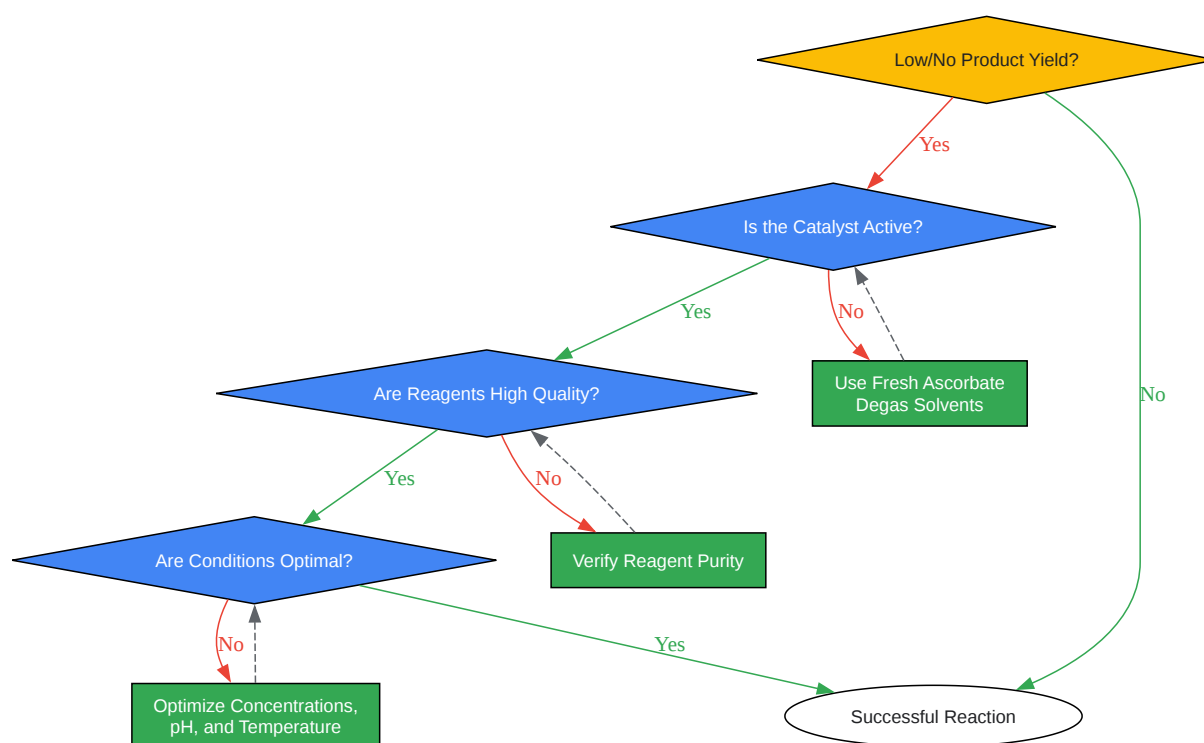

[Click to download full resolution via product page](#)

Caption: Troubleshooting decision tree for low yield in **GK13S** reactions.

Need Custom Synthesis?

BenchChem offers custom synthesis for rare earth carbides and specific isotopic labeling.

Email: info@benchchem.com or [Request Quote Online](#).

References

- [1. medchemexpress.com](https://www.medchemexpress.com) [[medchemexpress.com](https://www.medchemexpress.com)]
- [2. Click Chemistry](https://www.organic-chemistry.org) [[organic-chemistry.org](https://www.organic-chemistry.org)]
- [3. benchchem.com](https://www.benchchem.com) [[benchchem.com](https://www.benchchem.com)]
- [4. benchchem.com](https://www.benchchem.com) [[benchchem.com](https://www.benchchem.com)]
- [5. benchchem.com](https://www.benchchem.com) [[benchchem.com](https://www.benchchem.com)]
- [6. mdpi.com](https://www.mdpi.com) [[mdpi.com](https://www.mdpi.com)]
- [7. jenabioscience.com](https://www.jenabioscience.com) [[jenabioscience.com](https://www.jenabioscience.com)]
- [8. Problems and Solutions in Click Chemistry Applied to Drug Probes - PMC](#) [[pmc.ncbi.nlm.nih.gov](https://pubmed.ncbi.nlm.nih.gov/)]
- [9. benchchem.com](https://www.benchchem.com) [[benchchem.com](https://www.benchchem.com)]
- [10. interchim.fr](https://www.interchim.fr) [[interchim.fr](https://www.interchim.fr)]
- [11. Copper-Catalyzed Azide–Alkyne Click Chemistry for Bioconjugation - PMC](#) [[pmc.ncbi.nlm.nih.gov](https://pubmed.ncbi.nlm.nih.gov/)]
- [12. vectorlabs.com](https://www.vectorlabs.com) [[vectorlabs.com](https://www.vectorlabs.com)]
- [13. lumiprobe.com](https://www.lumiprobe.com) [[lumiprobe.com](https://www.lumiprobe.com)]
- To cite this document: BenchChem. [Technical Support Center: GK13S Click Chemistry Reactions]. BenchChem, [2026]. [Online PDF]. Available at: [<https://www.benchchem.com/product/b10862056/docs#technical-support-center-gk13s-click-chemistry-reactions>]

Disclaimer & Data Validity:

The information provided in this document is for Research Use Only (RUO) and is strictly not intended for diagnostic or therapeutic procedures. While BenchChem strives to provide accurate protocols, we make no warranties, express or implied, regarding the fitness of this product for every specific experimental setup.

Technical Support: The protocols provided are for reference purposes. Unsure if this reagent suits your experiment?

Need Industrial/Bulk Grade? [Request Custom Synthesis Quote](#)

BenchChem

Our mission is to be the trusted global source of essential and advanced chemicals, empowering scientists and researchers to drive progress in science and industry.

Contact

Address: 3281 E Guasti Rd

Ontario, CA 91761, United States

Phone: (601) 213-4426

Email: info@benchchem.com

[Contact our Ph.D. Support Team for a compatibility check](#)