

Validating the Specificity of BAY 1892005 for p53 Condensates: A Comparative Guide

Author: BenchChem Technical Support Team. **Date:** April 2026

Compound of Interest

Compound Name: BAY 1892005

Cat. No.: B10861678

[Get Quote](#)

For Researchers, Scientists, and Drug Development Professionals

This guide provides an objective comparison of **BAY 1892005**'s performance in modulating p53 condensates against other alternatives, supported by experimental data and detailed protocols.

Introduction to p53 Condensates and Therapeutic Targeting

The tumor suppressor protein p53 plays a critical role in preventing cancer by inducing cell cycle arrest or apoptosis in response to cellular stress.[1] Recent research has highlighted that p53 can undergo liquid-liquid phase separation (LLPS) to form dynamic, liquid-like structures known as condensates.[2][3] These condensates are thought to be important for p53's function; however, certain cancer-associated mutations in p53 can alter its phase separation properties, leading to the formation of aberrant, non-functional aggregates.[2][4] This has opened up a new avenue for therapeutic intervention, with small molecules being developed to specifically target and modulate these p53 condensates.

BAY 1892005 is a novel small molecule identified as a modulator of mutant p53 condensation. Unlike some other p53-targeting compounds that aim to reactivate mutant p53's transcriptional

functions, **BAY 1892005** acts on the physical state of p53 condensates without causing this reactivation. This guide delves into the specificity of **BAY 1892005** for p53 condensates, comparing its activity with other molecules and providing the necessary experimental framework for its validation.

Comparative Analysis of p53 Condensate Modulators

Here, we compare **BAY 1892005** with its analogue BAY 249716 and other small molecules known to affect p53 function.

Feature	BAY 1892005	BAY 249716	PRIMA-1 / APR-246	CP-31398	STIMA-1
Primary Mechanism	Modulates mutant p53 condensation ; leads to dissolution of structural mutant condensates.	Modulates mutant p53 condensation .	Covalently binds to thiols in mutant p53, restoring wild-type conformation and function. [5][6]	Stabilizes wild-type p53 and restores DNA-binding activity to some p53 mutants. [7][8] [9][10][11]	Stimulates mutant p53 DNA binding. [1][12]
Effect on p53 Condensates	Dissolves structural mutant p53 condensates; induces condensation of DNA-binding mutant p53.	Similar activity to BAY 1892005 in modulating mutant p53 condensates.	Inhibits the aggregation of mutant p53, which is a process related to condensate maturation. [13][14]	Primarily targets p53 function, with less characterized direct effects on condensates.	Primarily targets p53 function, with less characterized direct effects on condensates.
Binding to p53	Covalent binding to mutant p53 (R175H and Y220C confirmed).	Direct, non-covalent interaction with p53.	Covalent modification of mutant p53. [5][6]	Interacts with mutant p53 to restore wild-type function. [9]	Stimulates mutant p53 DNA binding in vitro. [1][12]
Mutant Specificity	Differentially affects structural (e.g., R175H, Y220C) vs. DNA-binding (e.g., R273H) mutants.	Shows activity across different p53 mutants.	Broadly active against various p53 mutants.	Active on both wild-type and some mutant p53. [7][9]	Active on certain p53 mutants (e.g., R175H). [1]
Reactivation of p53	Does not lead to mutant p53	Does not lead to mutant p53	Reactivates mutant p53	Restores transcriptiona	Induces expression of

Function	reactivation.	reactivation.	transcriptiona l function.[14]	l activation of p53 target genes.[7][9]	p53 target proteins.[1]
----------	---------------	---------------	-----------------------------------	---	----------------------------

Experimental Protocols

Detailed methodologies for key experiments to validate the specificity of **BAY 1892005** for p53 condensates are provided below.

Live-Cell Imaging of p53 Condensate Dynamics

This protocol allows for the real-time visualization of the effect of **BAY 1892005** on p53 condensates in living cells.

Materials:

- Cancer cell line expressing fluorescently tagged p53 (e.g., tagRFP-p53)
- Cell culture medium and supplements
- Glass-bottom imaging dishes
- Confocal microscope with live-cell imaging capabilities (environmental chamber to maintain 37°C and 5% CO₂)
- **BAY 1892005** stock solution (in DMSO)
- DMSO (vehicle control)

Procedure:

- Seed cells expressing fluorescently tagged p53 onto glass-bottom imaging dishes and allow them to adhere overnight.
- The following day, replace the medium with fresh, pre-warmed imaging medium.
- Place the dish on the microscope stage within the environmental chamber and allow the cells to equilibrate.

- Identify cells with clear p53 condensates.
- Acquire baseline images of the condensates before treatment.
- Add **BAY 1892005** to the desired final concentration (and an equivalent volume of DMSO to a control dish).
- Immediately begin time-lapse imaging, acquiring images every 1-5 minutes for a duration of 1-2 hours.
- Analyze the images to quantify changes in condensate number, size, and intensity over time.

In Vitro p53 Liquid-Liquid Phase Separation (LLPS) Assay

This assay assesses the direct effect of **BAY 1892005** on the formation of p53 condensates from purified protein.

Materials:

- Purified recombinant p53 protein (wild-type and mutants)
- LLPS buffer (e.g., 50 mM Tris-HCl pH 7.4, 150 mM NaCl, 5 mM DTT)
- Crowding agent (e.g., PEG-8000)
- **BAY 1892005** stock solution
- Microscopy slides and coverslips
- Fluorescence microscope

Procedure:

- Prepare a solution of purified p53 in LLPS buffer.
- Induce phase separation by adding a crowding agent (e.g., 10% w/v PEG-8000).

- Add **BAY 1892005** or vehicle control to the p53/PEG mixture.
- Incubate the mixture at room temperature for 15-30 minutes.
- Pipette a small volume of the mixture onto a microscope slide and cover with a coverslip.
- Image the sample using fluorescence or differential interference contrast (DIC) microscopy to observe the formation and morphology of p53 condensates.

Fluorescence Recovery After Photobleaching (FRAP)

FRAP is used to measure the fluidity of p53 condensates and how it is affected by **BAY 1892005**.

Materials:

- Cells expressing fluorescently tagged p53 with condensates
- Confocal microscope with FRAP capabilities
- **BAY 1892005**

Procedure:

- Prepare and treat cells with **BAY 1892005** as described in the live-cell imaging protocol.
- Identify a cell with a distinct p53 condensate.
- Acquire a few pre-bleach images of the condensate.
- Use a high-intensity laser to photobleach a region of interest (ROI) within the condensate.
- Immediately begin acquiring a time-lapse series of images of the condensate at a low laser intensity to monitor the recovery of fluorescence in the bleached area.
- Measure the fluorescence intensity in the bleached ROI over time and calculate the mobile fraction and the half-time of recovery.[\[15\]](#)[\[16\]](#)[\[17\]](#)

Mass Spectrometry for Covalent Binding Analysis

This method confirms the covalent interaction between **BAY 1892005** and p53.

Materials:

- Purified p53 protein
- **BAY 1892005**
- Mass spectrometer (e.g., ESI-MS)
- Incubation buffer

Procedure:

- Incubate purified p53 protein with **BAY 1892005** at a specific molar ratio for a defined period.
- As a control, incubate p53 with the vehicle (DMSO).
- Desalt the protein samples to remove excess compound and buffer components.
- Analyze the protein samples by mass spectrometry to determine the mass of the intact protein.
- A mass shift corresponding to the molecular weight of **BAY 1892005** will confirm covalent binding.[\[18\]](#)[\[19\]](#)

Immunofluorescence Staining for PML Nuclear Bodies

This experiment serves as a specificity control to ensure that **BAY 1892005** does not disrupt other nuclear condensates.

Materials:

- Cells cultured on coverslips
- **BAY 1892005**

- Paraformaldehyde (PFA) for fixation
- Permeabilization buffer (e.g., Triton X-100 in PBS)
- Blocking solution (e.g., BSA in PBS)
- Primary antibody against PML
- Fluorophore-conjugated secondary antibody
- DAPI for nuclear counterstaining
- Fluorescence microscope

Procedure:

- Treat cells with **BAY 1892005** or vehicle for the desired time.
- Fix the cells with 4% PFA.[\[20\]](#)[\[21\]](#)
- Permeabilize the cells to allow antibody entry.
- Block non-specific antibody binding sites.
- Incubate with the primary anti-PML antibody.
- Wash and incubate with the fluorescently labeled secondary antibody.
- Counterstain the nuclei with DAPI.
- Mount the coverslips and image the cells to visualize PML nuclear bodies.[\[20\]](#)[\[22\]](#) Compare the morphology and number of PML bodies in treated versus control cells.

Visualizing the Mechanism of Action

The following diagrams illustrate the proposed mechanism of p53 condensate formation and the differential effects of **BAY 1892005**.

p53 Condensate Formation and Aggregation Pathway

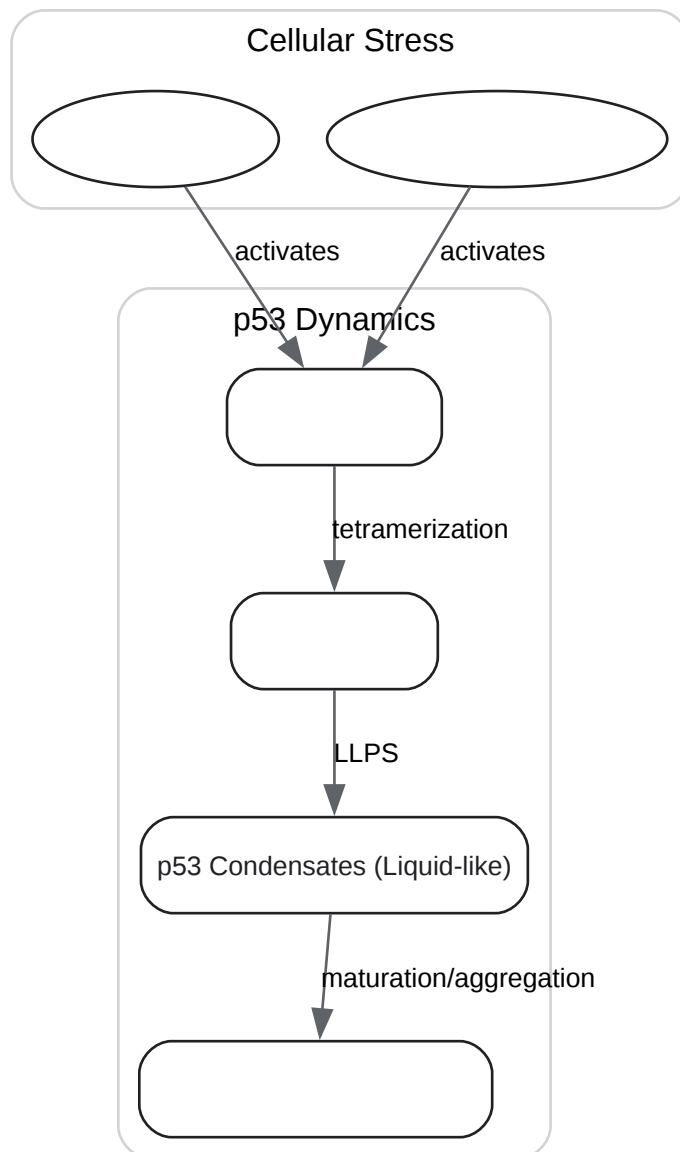

[Click to download full resolution via product page](#)

Caption: The p53 condensate formation and aggregation pathway.

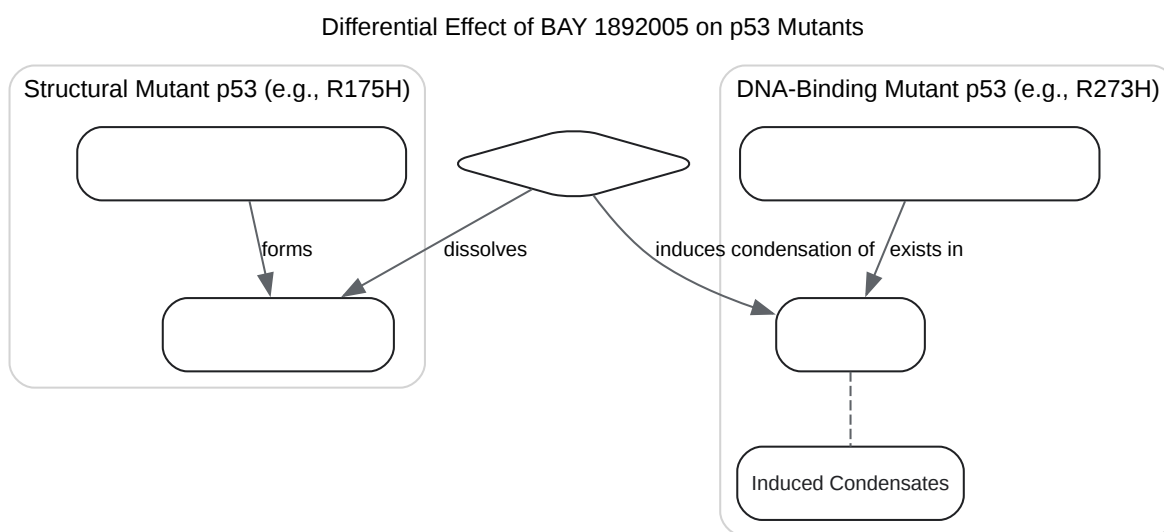

[Click to download full resolution via product page](#)

Caption: Differential effect of **BAY 1892005** on p53 mutants.

Conclusion

BAY 1892005 presents a targeted approach to modulating the aberrant condensation of mutant p53, a hallmark of many cancers. Its specificity for p53 condensates, particularly its differential effects on structural versus DNA-binding mutants, distinguishes it from other p53-targeting small molecules that primarily focus on reactivating p53's transcriptional functions. The experimental protocols outlined in this guide provide a robust framework for researchers to validate the specificity and mechanism of action of **BAY 1892005** and similar compounds. Further investigation into the nuanced effects of such molecules on the biophysical properties of p53 condensates will be crucial for the development of novel cancer therapies targeting the phase separation of oncoproteins.

Need Custom Synthesis?

BenchChem offers custom synthesis for rare earth carbides and specific isotopic labeling.

Email: info@benchchem.com or [Request Quote Online](#).

References

- 1. Mutant p53 targeting by the low molecular weight compound STIMA-1 - PMC [pmc.ncbi.nlm.nih.gov]
- 2. Nucleo-cytoplasmic environment modulates spatiotemporal p53 phase separation - PMC [pmc.ncbi.nlm.nih.gov]
- 3. Experimental kinetic mechanism of P53 condensation-amyloid aggregation - PubMed [pubmed.ncbi.nlm.nih.gov]
- 4. biorxiv.org [biorxiv.org]
- 5. researchgate.net [researchgate.net]
- 6. PRIMA-1 reactivates mutant p53 by covalent binding to the core domain - PubMed [pubmed.ncbi.nlm.nih.gov]
- 7. aacrjournals.org [aacrjournals.org]
- 8. The p53 stabilizing compound CP-31398 induces apoptosis by activating the intrinsic Bax/mitochondrial/caspase-9 pathway - PubMed [pubmed.ncbi.nlm.nih.gov]
- 9. CP-31398 restores mutant p53 tumor suppressor function and inhibits UVB-induced skin carcinogenesis in mice - PMC [pmc.ncbi.nlm.nih.gov]
- 10. The mutant p53-conformation modifying drug, CP-31398, can induce apoptosis of human cancer cells and can stabilize wild-type p53 protein - PubMed [pubmed.ncbi.nlm.nih.gov]
- 11. CP-31398 restores DNA-binding activity to mutant p53 in vitro but does not affect p53 homologs p63 and p73 - PubMed [pubmed.ncbi.nlm.nih.gov]
- 12. Mutant p53 targeting by the low molecular weight compound STIMA-1 - PubMed [pubmed.ncbi.nlm.nih.gov]
- 13. Phase separation of p53 precedes aggregation and is affected by oncogenic mutations and ligands - Chemical Science (RSC Publishing) DOI:10.1039/D1SC01739J [pubs.rsc.org]
- 14. p53 reactivation with induction of massive apoptosis-1 (PRIMA-1) inhibits amyloid aggregation of mutant p53 in cancer cells - PMC [pmc.ncbi.nlm.nih.gov]
- 15. researchgate.net [researchgate.net]
- 16. researchgate.net [researchgate.net]
- 17. Fluorescence Recovery After Photobleaching (FRAP) of Fluorescence Tagged Proteins in Dendritic Spines of Cultured Hippocampal Neurons - PMC [pmc.ncbi.nlm.nih.gov]
- 18. Protein-ligand affinity determinations using covalent labeling-mass spectrometry - PMC [pmc.ncbi.nlm.nih.gov]

- [19. Using Mass Spectrometry To Rapidly Facilitate Covalent Drug Discovery | Peak Proteins \[peakproteins.com\]](#)
- [20. ptglab.com \[ptglab.com\]](#)
- [21. Mutant p53 targeting by the low molecular weight compound STIMA-1 - PMC \[pmc.ncbi.nlm.nih.gov\]](#)
- [22. applications.emro.who.int \[applications.emro.who.int\]](#)
- To cite this document: BenchChem. [Validating the Specificity of BAY 1892005 for p53 Condensates: A Comparative Guide]. BenchChem, [2026]. [Online PDF]. Available at: [\[https://www.benchchem.com/product/b10861678/docs#validating-the-specificity-of-bay-1892005-for-p53-condensates-a-comparative-guide\]](https://www.benchchem.com/product/b10861678/docs#validating-the-specificity-of-bay-1892005-for-p53-condensates-a-comparative-guide)

Disclaimer & Data Validity:

The information provided in this document is for Research Use Only (RUO) and is strictly not intended for diagnostic or therapeutic procedures. While BenchChem strives to provide accurate protocols, we make no warranties, express or implied, regarding the fitness of this product for every specific experimental setup.

Technical Support: The protocols provided are for reference purposes. Unsure if this reagent suits your experiment?

Need Industrial/Bulk Grade? [Request Custom Synthesis Quote](#)

BenchChem

Our mission is to be the trusted global source of essential and advanced chemicals, empowering scientists and researchers to drive progress in science and industry.

Contact

Address: 3281 E Guasti Rd
Ontario, CA 91761, United States
Phone: (601) 213-4426
Email: info@benchchem.com

Contact our Ph.D. Support Team for a compatibility check