

Validating S63845 On-Target Activity in Resistant Cell Lines: A Comparative Guide

Author: BenchChem Technical Support Team. **Date:** April 2026

Compound of Interest

Compound Name: (S,R)-S63845

Cat. No.: B10861018

[Get Quote](#)

For Researchers, Scientists, and Drug Development Professionals

This guide provides a comprehensive comparison of the on-target activity of S63845, a potent and selective MCL-1 inhibitor, in both sensitive and resistant cancer cell lines. We present experimental data, detailed methodologies for key validation assays, and a comparative analysis with other BCL-2 family inhibitors to support researchers in navigating the challenges of MCL-1 inhibitor resistance.

Data Presentation: S63845 Efficacy in Sensitive vs. Resistant Cell Lines

The anti-proliferative activity of S63845 is primarily dictated by a cell's dependence on the anti-apoptotic protein MCL-1 for survival. Cell lines with a strong reliance on MCL-1 exhibit high sensitivity to S63845, while those that utilize other pro-survival proteins like BCL-2 or BCL-xL often display intrinsic or acquired resistance. The following tables summarize the half-maximal inhibitory concentration (IC50) values of S63845 and a comparator MCL-1 inhibitor, A-1210477, in various cancer cell lines, highlighting the distinction between sensitive and resistant populations.

Table 1: S63845 IC50 Values in Hematological Malignancy Cell Lines

Cell Line	Cancer Type	S63845 IC50 (nM)	Sensitivity Status
H929	Multiple Myeloma	< 100	High
AMO1	Multiple Myeloma	< 100	High
OPM2	Multiple Myeloma	< 100	High
OPM2-S63845 (Resistant)	Multiple Myeloma	> 1000 (>10-fold shift) [1]	Resistant
KMS12-BM	Multiple Myeloma	< 100	High
KMS12BM-S63845 (Resistant)	Multiple Myeloma	> 1000 (>10-fold shift) [1]	Resistant
MV4-11	Acute Myeloid Leukemia	< 100	High
MOLM-13	Acute Myeloid Leukemia	< 100	High
U-2946	Lymphoma	~100	High
HH	Cutaneous T-Cell Lymphoma	22[2]	High
HuT-78	Cutaneous T-Cell Lymphoma	110[2]	Moderate
MyLa	Cutaneous T-Cell Lymphoma	> 2000[2]	Resistant
SeAx	Cutaneous T-Cell Lymphoma	> 2000[2]	Resistant

Table 2: S63845 IC50 Values in Solid Tumor Cell Lines

Cell Line	Cancer Type	S63845 IC50 (nM)	Sensitivity Status
MDA-MB-468	Triple-Negative Breast Cancer	141.2[3]	Sensitive
HCC1143	Triple-Negative Breast Cancer	3100[3]	Sensitive
MDA-MB-231	Triple-Negative Breast Cancer	> 4000[3]	Resistant
Hs-578T	Triple-Negative Breast Cancer	> 4000[3]	Resistant
HeLa	Cervical Cancer	Sensitive[4]	Sensitive
SiHa	Cervical Cancer	Resistant[4]	Resistant
C33A	Cervical Cancer	Resistant[4]	Resistant
CaSki	Cervical Cancer	Resistant[4]	Resistant

Table 3: Comparative Efficacy of MCL-1 Inhibitors

Cell Line	Cancer Type	S63845 IC50	A-1210477 IC50	Fold Difference (A-1210477/S63845)
H929	Multiple Myeloma	Potent (nM range)	Less Potent (μ M range)	~1000-fold more potent[5]
OPM2-S63845 (Resistant)	Multiple Myeloma	>10-fold shift	>5-10-fold shift[1]	-
KMS12BM-S63845 (Resistant)	Multiple Myeloma	>10-fold shift	>5-10-fold shift[1]	-

Experimental Protocols: Validating On-Target Activity

To confirm that S63845 exerts its cytotoxic effects through the specific inhibition of MCL-1, a series of key experiments are typically performed. Below are detailed methodologies for these assays.

Co-Immunoprecipitation (Co-IP) to Demonstrate Disruption of MCL-1/BAK Interaction

This assay verifies that S63845 disrupts the interaction between MCL-1 and the pro-apoptotic protein BAK, a crucial step in initiating apoptosis.

Protocol:

- Cell Lysis:
 - Treat S63845-sensitive and resistant cells with the desired concentrations of S63845 or a vehicle control (e.g., DMSO) for a specified time (e.g., 4-6 hours).
 - Harvest cells and wash with ice-cold PBS.
 - Lyse cells in a non-denaturing lysis buffer (e.g., 1% CHAPS in TBS) supplemented with protease and phosphatase inhibitors.
 - Incubate on ice for 30 minutes with periodic vortexing.
 - Clarify the lysate by centrifugation at 14,000 x g for 15 minutes at 4°C.
- Immunoprecipitation:
 - Pre-clear the cell lysates by incubating with protein A/G-agarose beads for 1 hour at 4°C.
 - Incubate the pre-cleared lysates with an anti-MCL-1 antibody or an isotype control IgG overnight at 4°C with gentle rotation.
 - Add protein A/G-agarose beads and incubate for another 2-4 hours at 4°C.

- Washing and Elution:
 - Wash the beads three to five times with lysis buffer.
 - Elute the immunoprecipitated proteins by boiling the beads in SDS-PAGE sample buffer.
- Western Blot Analysis:
 - Separate the eluted proteins by SDS-PAGE and transfer to a PVDF membrane.
 - Probe the membrane with primary antibodies against MCL-1 and BAK.
 - Incubate with the appropriate HRP-conjugated secondary antibodies and visualize using an enhanced chemiluminescence (ECL) detection system.

Cytochrome c Release Assay

This assay determines whether the inhibition of MCL-1 by S63845 leads to the release of cytochrome c from the mitochondria into the cytosol, a key event in the intrinsic apoptotic pathway.

Protocol:

- Cell Treatment and Fractionation:
 - Treat cells with S63845 or a vehicle control.
 - Harvest and wash the cells with ice-cold PBS.
 - Resuspend the cell pellet in a hypotonic buffer and incubate on ice to swell the cells.
 - Homogenize the cells using a Dounce homogenizer.
 - Centrifuge the homogenate at a low speed (e.g., 700 x g) to pellet nuclei and intact cells.
 - Transfer the supernatant to a new tube and centrifuge at a higher speed (e.g., 10,000 x g) to pellet the mitochondria. The resulting supernatant is the cytosolic fraction.
- Western Blot Analysis:

- Measure the protein concentration of the cytosolic and mitochondrial fractions.
- Separate equal amounts of protein from each fraction by SDS-PAGE.
- Transfer the proteins to a PVDF membrane.
- Probe the membrane with a primary antibody against cytochrome c.
- To ensure proper fractionation, probe for a cytosolic marker (e.g., GAPDH) and a mitochondrial marker (e.g., COX IV).
- Visualize the bands using an ECL detection system.

Caspase Activity Assay

This assay quantifies the activation of executioner caspases, such as caspase-3 and caspase-7, which are downstream effectors of the apoptotic cascade initiated by MCL-1 inhibition.

Protocol:

- Cell Lysis:
 - Plate cells in a 96-well plate and treat with various concentrations of S63845.
 - After the desired incubation period, add a lysis buffer provided in a commercial caspase activity kit (e.g., Caspase-Glo® 3/7 Assay).
- Caspase Activity Measurement:
 - Incubate the plate at room temperature to allow for cell lysis and caspase cleavage of a luminogenic or fluorogenic substrate.
 - Measure the luminescence or fluorescence using a plate reader. The signal intensity is directly proportional to the amount of active caspase-3/7.

Mandatory Visualizations

Signaling Pathway Diagrams

The following diagrams, generated using Graphviz (DOT language), illustrate the mechanism of action of S63845 and the pathways leading to resistance.

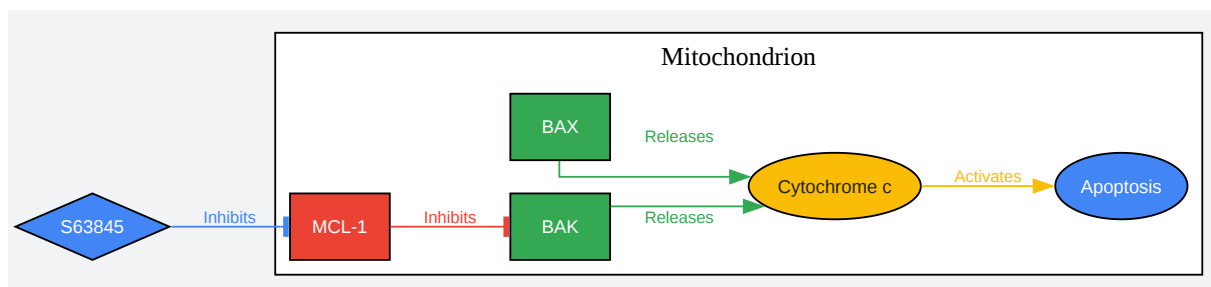

[Click to download full resolution via product page](#)

Caption: Mechanism of S63845-induced apoptosis.

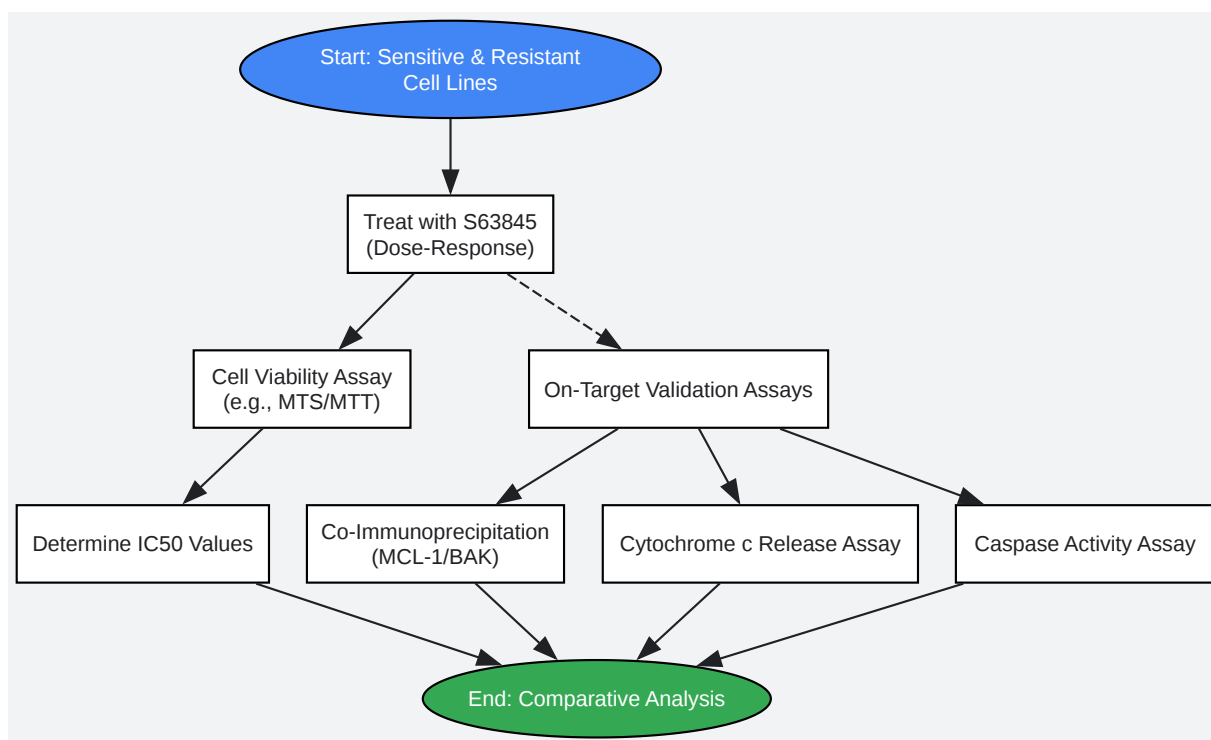
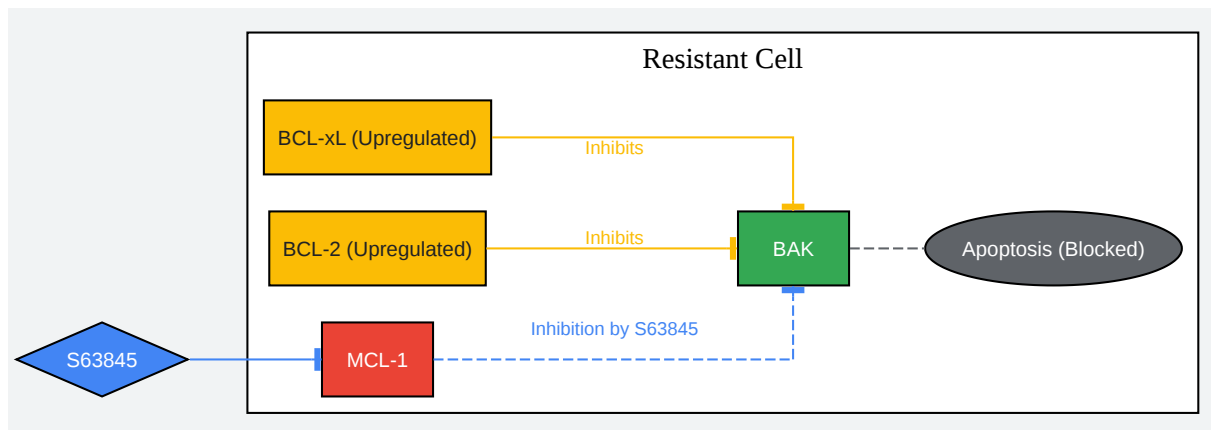

[Click to download full resolution via product page](#)

Need Custom Synthesis?

BenchChem offers custom synthesis for rare earth carbides and specific isotopic labeling.

Email: info@benchchem.com or [Request Quote Online](#).

References

- [1. Heterogeneous modulation of Bcl-2 family members and drug efflux mediate MCL-1 inhibitor resistance in multiple myeloma - PMC \[pmc.ncbi.nlm.nih.gov\]](#)
- [2. benchchem.com \[benchchem.com\]](#)
- [3. Myeloid Cell Leukemia 1 Small Molecule Inhibitor S63845 Synergizes with Cisplatin in Triple-Negative Breast Cancer - PMC \[pmc.ncbi.nlm.nih.gov\]](#)
- [4. Co-inhibition of BCL-XL and MCL-1 with selective BCL-2 family inhibitors enhances cytotoxicity of cervical cancer cell lines - PMC \[pmc.ncbi.nlm.nih.gov\]](#)
- [5. apexbt.com \[apexbt.com\]](#)
- To cite this document: BenchChem. [Validating S63845 On-Target Activity in Resistant Cell Lines: A Comparative Guide]. BenchChem, [2026]. [Online PDF]. Available at: [\[https://www.benchchem.com/product/b10861018/docs#validating-s63845-on-target-activity-in-resistant-cell-lines-a-comparative-guide\]](https://www.benchchem.com/product/b10861018/docs#validating-s63845-on-target-activity-in-resistant-cell-lines-a-comparative-guide)

Disclaimer & Data Validity:

The information provided in this document is for Research Use Only (RUO) and is strictly not intended for diagnostic or therapeutic procedures. While BenchChem strives to provide accurate protocols, we make no warranties, express or implied, regarding the fitness of this product for every specific experimental setup.

Technical Support: The protocols provided are for reference purposes. Unsure if this reagent suits your experiment?

Need Industrial/Bulk Grade? [Request Custom Synthesis Quote](#)

BenchChem

Our mission is to be the trusted global source of essential and advanced chemicals, empowering scientists and researchers to drive progress in science and industry.

Contact

Address: 3281 E Guasti Rd
Ontario, CA 91761, United States
Phone: (601) 213-4426
Email: info@benchchem.com

Contact our Ph.D. Support Team for a compatibility check