

Technical Support Center: PTPN22 Inhibitor (e.g., Lyp-IN-4) Experiments

Author: BenchChem Technical Support Team. **Date:** April 2026

Compound of Interest

Compound Name: *Lyp-IN-4*
Cat. No.: *B10861650*

[Get Quote](#)

This technical support center provides troubleshooting guides and frequently asked questions (FAQs) for researchers utilizing inhibitors of Protein Tyrosine Phosphatase Non-receptor Type 22 (PTPN22), also known as Lymphoid Tyrosine Phosphatase (Lyp). While the specific compound "**Lyp-IN-4**" is not found in the reviewed literature, this guide focuses on well-characterized PTPN22 inhibitors like L-1 and I-C11, with the principles being broadly applicable to other small molecule inhibitors of PTPN22.

Frequently Asked Questions (FAQs)

Q1: What is PTPN22 and why is it a therapeutic target?

PTPN22 is a protein tyrosine phosphatase predominantly expressed in immune cells.[1][2] It acts as a crucial negative regulator of T-cell receptor (TCR) signaling.[1][2][3][4] PTPN22 achieves this by dephosphorylating key signaling molecules such as Lck and ZAP70, which are essential for T-cell activation.[2][3][4] Due to its role in dampening immune responses, genetic variants of PTPN22 that lead to altered function are associated with a variety of autoimmune diseases, including type 1 diabetes and rheumatoid arthritis.[5] Consequently, inhibiting PTPN22 is a promising therapeutic strategy for enhancing immune responses, particularly in the context of cancer immunotherapy.[2][3][4]

Q2: What are the common readouts to measure the effectiveness of a PTPN22 inhibitor in a cell-based assay?

The most common method to assess the cellular activity of a PTPN22 inhibitor is to measure the phosphorylation status of its downstream targets. A successful inhibition of PTPN22 should lead to an increase in the phosphorylation of Lck at tyrosine 394 (Y394) and ZAP70 at tyrosine 493 (Y493).[2][3] This can be quantified using techniques like Western blotting or flow cytometry with phospho-specific antibodies. Furthermore, downstream effects of enhanced TCR signaling, such as increased production of cytokines like IL-2 and IFN- γ , or activation of transcription factors like NFAT/AP-1, can also be used as readouts.[3]

Q3: How should I prepare and store my PTPN22 inhibitor?

Most small molecule inhibitors, including PTPN22 inhibitors, are typically dissolved in dimethyl sulfoxide (DMSO) to create a high-concentration stock solution. For PTPN22-IN-1 (L-1), it is soluble in DMSO at 10 mg/mL with the aid of ultrasonication and warming to 60°C.[6] It is crucial to use freshly opened, anhydrous DMSO as hygroscopic DMSO can significantly impact solubility.[6] Stock solutions should be stored at -20°C or -80°C to maintain stability. For PTPN22-IN-1, storage at -80°C is recommended for up to 6 months, and at -20°C for up to 1 month.[6] Avoid repeated freeze-thaw cycles.

PTPN22 Inhibitor Data

Quantitative data for two well-characterized PTPN22 inhibitors are summarized below.

Inhibitor	Target	IC50	K _i	Selectivity	In Vivo Application
L-1 (PTPN22-IN-1)	PTPN22	1.4 ± 0.2 μM	0.50 ± 0.03 μM	7- to 10-fold selective over 16 other phosphatases	10 mg/kg intraperitoneal administration in mice
I-C11	PTPN22	4.6 ± 0.4 μM	2.9 ± 0.5 μM	>7-fold selective over most PTPs, 2.6-fold over PTP1B	Not reported

Signaling Pathway and Experimental Workflow

Below are diagrams illustrating the PTPN22 signaling pathway and a general experimental workflow for testing a PTPN22 inhibitor.

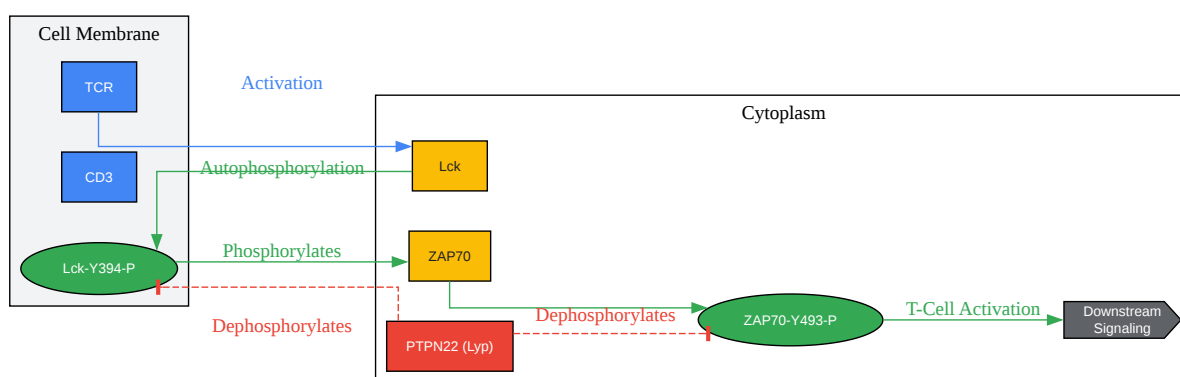

[Click to download full resolution via product page](#)

Caption: PTPN22 (Lyp) negatively regulates TCR signaling.

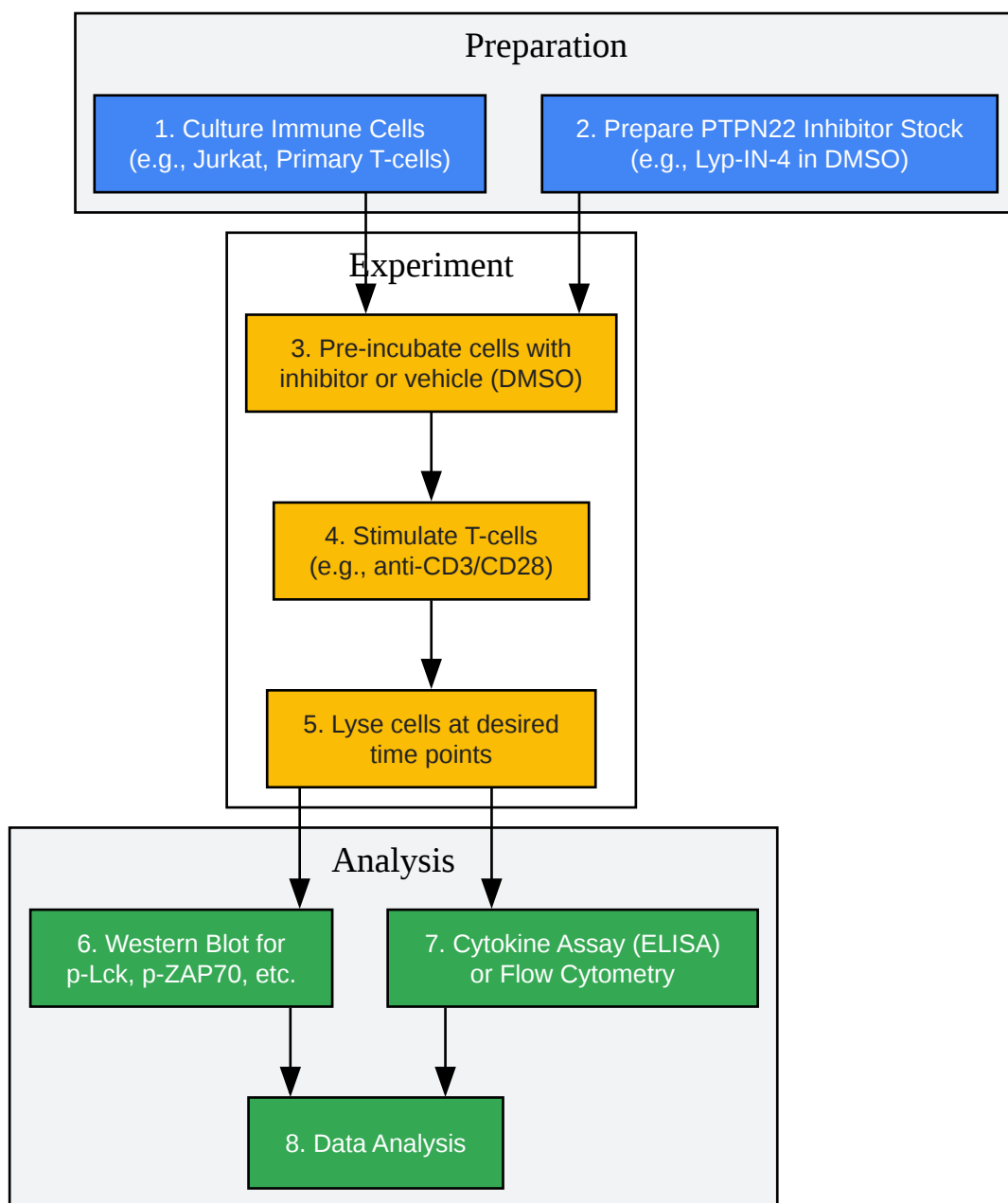

[Click to download full resolution via product page](#)

Caption: Workflow for testing PTPN22 inhibitors in cells.

Troubleshooting Guide

Problem	Possible Cause(s)	Suggested Solution(s)
No or weak inhibition of PTPN22 activity	Inhibitor instability: Compound has degraded due to improper storage or multiple freeze-thaw cycles.	Prepare fresh dilutions of the inhibitor from a new stock. Ensure proper storage conditions are met (-20°C or -80°C).[6]
Low inhibitor concentration: The concentration used is below the effective range (IC50).	Perform a dose-response experiment to determine the optimal concentration. For L-1, the IC50 is 1.4 µM.[6][7][8]	
Poor cell permeability: The inhibitor is not efficiently entering the cells.	Increase incubation time with the inhibitor before cell stimulation. Consult literature for reported cellular efficacy of the specific inhibitor.	
Inconsistent results between experiments	Variability in cell culture: Cell passage number, density, or health can affect signaling responses.	Use cells within a consistent and low passage number range. Ensure consistent cell seeding densities and viability.
Inhibitor precipitation: The inhibitor may be precipitating out of the cell culture medium.	Ensure the final DMSO concentration in the culture medium is low (typically <0.5%) to maintain solubility. Visually inspect for any precipitate.	
Pipetting errors: Inaccurate pipetting can lead to variability in inhibitor concentrations.	Use calibrated pipettes and prepare master mixes for inhibitor dilutions to minimize variability.	

Observed cellular effects are not due to PTPN22 inhibition (off-target effects)

Inhibitor lacks specificity: The compound may be inhibiting other phosphatases or cellular targets.

Review the selectivity profile of your inhibitor. For example, L-1 is 7- to 10-fold selective for PTPN22 over other phosphatases.[3][7][8][9]

Perform control experiments:

Use a cell line that does not express PTPN22 (e.g., HeLa cells) to see if the inhibitor still elicits the same effect.[3]

Alternatively, use cells expressing an inhibitor-insensitive mutant of PTPN22.

[3]

Cytotoxicity: The observed effects may be due to the inhibitor being toxic to the cells at the concentration used.

Perform a cell viability assay (e.g., MTT or trypan blue exclusion) to determine the cytotoxic concentration of the inhibitor. Ensure the experimental concentration is well below the toxic threshold.

Experimental Protocols

Protocol 1: Western Blot Analysis of Lck and ZAP70 Phosphorylation in Jurkat T-cells

- **Cell Culture:** Culture Jurkat T-cells in RPMI-1640 medium supplemented with 10% fetal bovine serum (FBS) and 1% penicillin-streptomycin at 37°C in a 5% CO₂ incubator.
- **Inhibitor Preparation:** Prepare a 10 mM stock solution of the PTPN22 inhibitor (e.g., L-1) in anhydrous DMSO. Make serial dilutions in cell culture medium to achieve the desired final concentrations.
- **Cell Treatment:** Seed Jurkat cells at a density of 1 x 10⁶ cells/mL in a 6-well plate. Pre-incubate the cells with the PTPN22 inhibitor or a vehicle control (DMSO) for 1-2 hours at 37°C.

- T-cell Stimulation: Stimulate the T-cells by adding anti-CD3 and anti-CD28 antibodies (e.g., 1 µg/mL each) for 5-15 minutes at 37°C.
- Cell Lysis: Immediately place the plate on ice and wash the cells once with ice-cold phosphate-buffered saline (PBS). Lyse the cells in RIPA buffer supplemented with protease and phosphatase inhibitors.
- Protein Quantification: Determine the protein concentration of each lysate using a BCA protein assay.
- Western Blotting:
 - Load equal amounts of protein (e.g., 20-30 µg) onto an SDS-PAGE gel.
 - Transfer the separated proteins to a PVDF membrane.
 - Block the membrane with 5% non-fat milk or bovine serum albumin (BSA) in Tris-buffered saline with 0.1% Tween 20 (TBST) for 1 hour at room temperature.
 - Incubate the membrane with primary antibodies against phospho-Lck (Y394), total Lck, phospho-ZAP70 (Y493), and total ZAP70 overnight at 4°C.
 - Wash the membrane with TBST and incubate with HRP-conjugated secondary antibodies for 1 hour at room temperature.
 - Detect the signal using an enhanced chemiluminescence (ECL) substrate and image the blot.
- Data Analysis: Quantify the band intensities and normalize the phosphorylated protein levels to the total protein levels. Compare the inhibitor-treated samples to the vehicle control.

Need Custom Synthesis?

BenchChem offers custom synthesis for rare earth carbides and specific isotopic labeling.

Email: info@benchchem.com or [Request Quote Online](#).

References

- 1. JCI - Systemic inhibition of PTPN22 augments anticancer immunity [[jci.org](#)]
- 2. Systemic inhibition of PTPN22 augments anticancer immunity - PMC [[pmc.ncbi.nlm.nih.gov](#)]
- 3. PTPN22: Structure, Function, and Developments in Inhibitor Discovery with Applications for Immunotherapy - PMC [[pmc.ncbi.nlm.nih.gov](#)]
- 4. [aacr.org](#) [[aacr.org](#)]
- 5. In silico screening for PTPN22 inhibitors: active hits from an inactive phosphatase conformation - PubMed [[pubmed.ncbi.nlm.nih.gov](#)]
- 6. [medchemexpress.com](#) [[medchemexpress.com](#)]
- 7. PTPN22 inhibitor L-1 | PTPN22 inhibitor | Probechem Biochemicals [[probechem.com](#)]
- 8. PTPN22-IN-1 - MedChem Express [[bioscience.co.uk](#)]
- 9. [researchgate.net](#) [[researchgate.net](#)]
- To cite this document: BenchChem. [Technical Support Center: PTPN22 Inhibitor (e.g., Lyp-IN-4) Experiments]. BenchChem, [2026]. [Online PDF]. Available at: [<https://www.benchchem.com/product/b10861650/docs#technical-support-center-ptpn22-inhibitor-e-g-lyp-in-4-experiments>]

Disclaimer & Data Validity:

The information provided in this document is for Research Use Only (RUO) and is strictly not intended for diagnostic or therapeutic procedures. While BenchChem strives to provide accurate protocols, we make no warranties, express or implied, regarding the fitness of this product for every specific experimental setup.

Technical Support: The protocols provided are for reference purposes. Unsure if this reagent suits your experiment?

Need Industrial/Bulk Grade? [Request Custom Synthesis Quote](#)

BenchChem

Our mission is to be the trusted global source of essential and advanced chemicals, empowering scientists and researchers to drive progress in science and industry.

Contact

Address: 3281 E Guasti Rd

Ontario, CA 91761, United States

Phone: (601) 213-4426

Email: info@benchchem.com

[Contact our Ph.D. Support Team for a compatibility check](#)