

Technical Support Center: Assessing PDZ1i Stability in Cell Culture Media

Author: BenchChem Technical Support Team. **Date:** April 2026

Compound of Interest

Compound Name: PDZ1i
Cat. No.: B10861142

[Get Quote](#)

Welcome to the technical support center for **PDZ1i**. This resource is designed to assist researchers, scientists, and drug development professionals in effectively assessing the stability of **PDZ1i** in cell culture media. Below you will find troubleshooting guides and frequently asked questions (FAQs) to address common challenges encountered during experiments.

Frequently Asked Questions (FAQs)

Q1: What is **PDZ1i** and how does it work?

A1: **PDZ1i** is a small molecule inhibitor that targets the PDZ1 domain of the scaffolding protein MDA-9/Syntenin.[1][2] By binding to this domain, **PDZ1i** disrupts the protein-protein interactions that are crucial for downstream signaling pathways involved in cancer metastasis, including those mediated by FAK, Src, and STAT3.[2][3][4] This inhibition can lead to a reduction in tumor cell invasion, migration, and angiogenesis.

Q2: Why is it important to assess the stability of **PDZ1i** in cell culture media?

A2: Understanding the stability of **PDZ1i** in your specific cell culture setup is critical for the accurate interpretation of experimental results. If the inhibitor degrades over the course of an

experiment, the effective concentration exposed to the cells will decrease, potentially leading to an underestimation of its potency and misleading conclusions. Stability assessment helps to ensure that the observed biological effects are attributable to the intended concentration of the active compound.

Q3: What are the primary factors that can affect **PDZ1i** stability in cell culture media?

A3: Several factors can influence the stability of a small molecule inhibitor like **PDZ1i** in cell culture media:

- **Enzymatic Degradation:** If the media is supplemented with serum, such as Fetal Bovine Serum (FBS), it will contain various enzymes like proteases and esterases that can metabolize the compound.
- **pH Instability:** The pH of the cell culture medium (typically between 7.2 and 7.4) can lead to the degradation of compounds that are sensitive to pH changes.
- **Binding to Media Components:** **PDZ1i** may bind to proteins like albumin present in serum, which can affect its availability and apparent stability.
- **Chemical Reactivity:** The compound may react with components of the cell culture medium itself.
- **Physical Factors:** Temperature (typically 37°C), light exposure, and the material of the culture vessel can also impact stability.

Q4: What is the expected half-life of **PDZ1i** in cell culture media?

A4: Currently, there is no publicly available data specifying the half-life of **PDZ1i** in common cell culture media such as DMEM or RPMI-1640. The stability of small molecules can vary significantly depending on their chemical structure and the experimental conditions. One study has reported a half-life of 9 hours for **PDZ1i** in vivo, but this is not directly transferable to in vitro conditions due to differences in metabolism and clearance mechanisms. Therefore, it is highly recommended that researchers determine the stability of **PDZ1i** under their specific experimental conditions.

Q5: How can I prepare and store **PDZ1i** stock solutions?

A5: For optimal stability, it is recommended to prepare a high-concentration stock solution of **PDZ1i** in a suitable solvent like DMSO. This stock solution should be aliquoted into small, single-use volumes to avoid repeated freeze-thaw cycles and stored at -20°C or -80°C, protected from light. When preparing working solutions, the final concentration of DMSO in the cell culture medium should be kept low (typically below 0.5%) to avoid solvent-induced cytotoxicity.

Troubleshooting Guides

This section addresses common issues that may arise during the assessment of **PDZ1i** stability.

Problem	Possible Cause(s)	Troubleshooting Steps
Inconsistent results between replicate experiments	Incomplete solubilization of PDZ1i. Inconsistent timing of sample collection. Variability in analytical measurements (e.g., HPLC, LC-MS).	Ensure the stock solution is fully dissolved before preparing working solutions. Adhere to a strict time course for sample collection. Validate your analytical method for linearity, precision, and accuracy.
Rapid loss of PDZ1i from the medium	High rate of degradation under experimental conditions. Adsorption to the surface of the cell culture plates or pipette tips. Rapid uptake by cells (if present).	Perform a stability check in a simpler buffer system (e.g., PBS) to assess inherent aqueous stability. Use low-protein-binding labware. Include a cell-free control to differentiate between degradation and cellular uptake.
No detectable degradation of PDZ1i	The compound is highly stable under your experimental conditions. The analytical method is not sensitive enough to detect small changes.	Extend the time course of the experiment to observe potential long-term degradation. Optimize the sensitivity of your analytical method.
Precipitation of PDZ1i in the cell culture medium	The concentration of PDZ1i exceeds its solubility in the medium. Interaction with media components.	Determine the maximum soluble concentration of PDZ1i in your specific medium. Ensure the medium is pre-warmed to 37°C before adding the compound. Consider using a co-solvent if solubility issues persist and it is compatible with your cell line.

Data Presentation

The stability of **PDZ1i** should be determined by quantifying the percentage of the intact compound remaining at various time points relative to the initial concentration at time zero. The data should be presented in a clear and organized table. Below is a template table that can be used to present your experimental findings.

Table 1: Stability of **PDZ1i** in Different Cell Culture Media at 37°C

Time (hours)	DMEM (% Remaining)	DMEM + 10% FBS (% Remaining)	RPMI-1640 (% Remaining)	RPMI-1640 + 10% FBS (% Remaining)
0	100 ± 0.0	100 ± 0.0	100 ± 0.0	100 ± 0.0
2				
8				
24				
48				
72				

Data should be presented as mean ± standard deviation (n=3). The percentage remaining is calculated by comparing the peak area of PDZ1i at each time point to the peak area at time 0 using a validated analytical method like HPLC or LC-MS.

Experimental Protocols

This section provides a detailed methodology for assessing the stability of **PDZ1i** in cell culture media.

Protocol: Assessing **PDZ1i** Stability in Cell Culture Media using HPLC-MS

1. Materials and Reagents

- **PDZ1i**
- DMSO, HPLC grade
- Cell culture media (e.g., DMEM, RPMI-1640)
- Fetal Bovine Serum (FBS)
- Acetonitrile, HPLC grade
- Formic acid, HPLC grade
- Water, HPLC grade
- Sterile microcentrifuge tubes
- Sterile, low-protein-binding multi-well plates
- Incubator (37°C, 5% CO₂)
- HPLC-MS system with a C18 reverse-phase column

2. Preparation of Solutions

- **PDZ1i** Stock Solution (10 mM): Prepare a 10 mM stock solution of **PDZ1i** in DMSO.
- Working Solutions (10 μM): Prepare working solutions of **PDZ1i** by diluting the stock solution in the desired cell culture media (with and without 10% FBS) to a final concentration of 10 μM.

3. Experimental Procedure

- Add 1 mL of each 10 μM **PDZ1i** working solution to triplicate wells of a sterile, low-protein-binding 24-well plate.
- Incubate the plate at 37°C in a humidified incubator with 5% CO₂.

- At designated time points (e.g., 0, 2, 8, 24, 48, and 72 hours), collect a 100 μL aliquot from each well. The 0-hour time point should be collected immediately after adding the working solution.
- To each 100 μL aliquot, add 200 μL of acetonitrile containing an internal standard to precipitate proteins and stop any enzymatic degradation.
- Vortex the samples and centrifuge at high speed (e.g., 14,000 $\times g$) for 10 minutes to pellet the precipitated proteins.
- Carefully transfer the supernatant to HPLC vials for analysis.

4. HPLC-MS Analysis

- Column: C18 reverse-phase column (e.g., 2.1 \times 50 mm, 1.8 μm).
- Mobile Phase A: Water with 0.1% formic acid.
- Mobile Phase B: Acetonitrile with 0.1% formic acid.
- Gradient: A suitable gradient to separate **PDZ1i** from media components (e.g., 5% to 95% B over 5 minutes).
- Flow Rate: 0.4 mL/min.
- Detection: Mass spectrometry detection of the parent ion of **PDZ1i**.

5. Data Analysis

- Integrate the peak area of the **PDZ1i** parent ion for each time point.
- Calculate the percentage of **PDZ1i** remaining at each time point relative to the average peak area at time 0.
- Plot the percentage of **PDZ1i** remaining versus time to determine the degradation kinetics and estimate the half-life ($t_{1/2}$) of the compound in each condition.

Visualizations

MDA-9/Syntenin Signaling Pathway

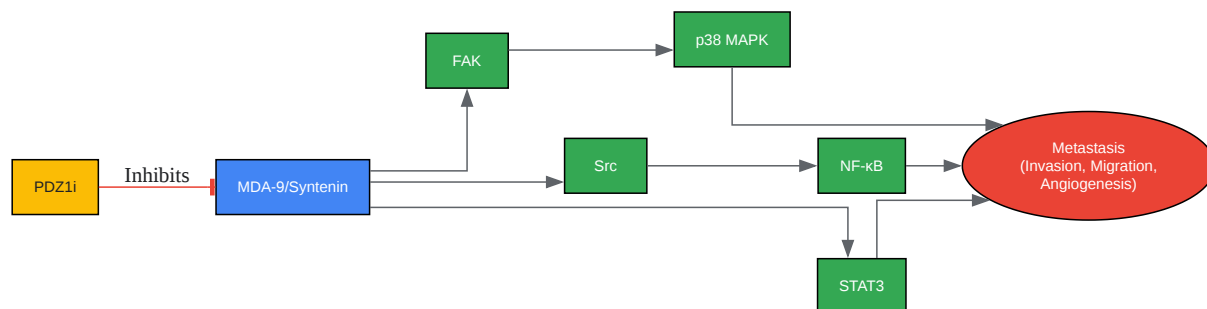

[Click to download full resolution via product page](#)

Caption: **PDZ1i** inhibits the pro-metastatic signaling of MDA-9/Syntenin.

Experimental Workflow for **PDZ1i** Stability Assessment

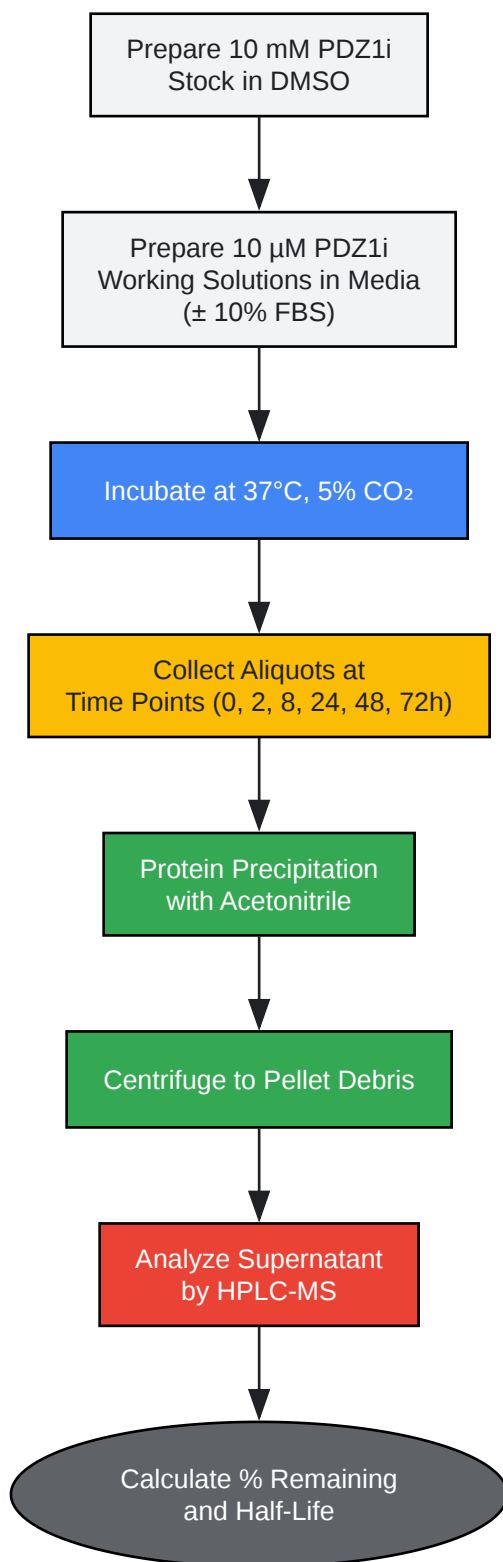

[Click to download full resolution via product page](#)

Caption: Workflow for assessing **PDZ1i** stability in cell culture media.

Troubleshooting Logic for **PDZ1i** Stability Assays

Caption: A logical approach to troubleshooting inconsistent **PDZ1i** stability results.

Need Custom Synthesis?

BenchChem offers custom synthesis for rare earth carbides and specific isotopic labeling.

Email: info@benchchem.com or [Request Quote Online](#).

References

- [1. benchchem.com \[benchchem.com\]](https://www.benchchem.com)
- [2. Overcoming Challenges in Small-Molecule Drug Bioavailability: A Review of Key Factors and Approaches - PMC \[pmc.ncbi.nlm.nih.gov\]](https://pubmed.ncbi.nlm.nih.gov/)
- [3. benchchem.com \[benchchem.com\]](https://www.benchchem.com)
- [4. researchgate.net \[researchgate.net\]](https://www.researchgate.net)
- To cite this document: BenchChem. [Technical Support Center: Assessing PDZ1i Stability in Cell Culture Media]. BenchChem, [2026]. [Online PDF]. Available at: [\[https://www.benchchem.com/product/b10861142/docs#technical-support-center-assessing-pdz1i-stability-in-cell-culture-media\]](https://www.benchchem.com/product/b10861142/docs#technical-support-center-assessing-pdz1i-stability-in-cell-culture-media)

Disclaimer & Data Validity:

The information provided in this document is for Research Use Only (RUO) and is strictly not intended for diagnostic or therapeutic procedures. While BenchChem strives to provide accurate protocols, we make no warranties, express or implied, regarding the fitness of this product for every specific experimental setup.

Technical Support: The protocols provided are for reference purposes. Unsure if this reagent suits your experiment?

Need Industrial/Bulk Grade? [Request Custom Synthesis Quote](#)

BenchChem

Our mission is to be the trusted global source of essential and advanced chemicals, empowering scientists and researchers to drive progress in science and industry.

Contact

Address: 3281 E Guasti Rd

Ontario, CA 91761, United States

Phone: (601) 213-4426

Email: info@benchchem.com

[Contact our Ph.D. Support Team for a compatibility check](#)