

In-Depth Technical Guide: The Compound DS69910557 and Its Effects on Bone Metabolism

Author: BenchChem Technical Support Team. **Date:** April 2026

Compound of Interest

Compound Name: DS69910557

Cat. No.: B10861409

[Get Quote](#)

Notice: Publicly available scientific literature, clinical trial registries, and patent databases contain no specific information regarding a compound designated "**DS69910557**." This identifier may correspond to an internal, preclinical research code that has not yet been disclosed.

The following guide is a structured template demonstrating the expected content and format for an in-depth technical analysis of a novel therapeutic agent for bone metabolism. Should information on **DS69910557** become public, this framework can be populated accordingly. The placeholder data and diagrams are based on common mechanisms in bone metabolism research.

Executive Summary

This document provides a comprehensive technical overview of **DS69910557**, a novel investigational agent, and its putative effects on bone metabolism. It is intended for researchers, scientists, and professionals in the field of drug development. The guide details the compound's hypothesized mechanism of action, summarizes key preclinical and clinical data through structured tables, outlines detailed experimental methodologies, and visualizes relevant biological pathways and workflows.

Hypothesized Mechanism of Action

This section would typically describe the molecular target and signaling pathway of the compound. As an illustrative example, we will proceed assuming **DS69910557** is an inhibitor of Sclerostin (SOST), a key negative regulator of bone formation.

Sclerostin, primarily secreted by osteocytes, inhibits bone formation by binding to LRP5/6 receptors, thereby antagonizing the Wnt signaling pathway. Inhibition of the Wnt pathway prevents the nuclear translocation of β -catenin, which is required for the transcription of genes essential for osteoblast differentiation and function.

DS69910557 is hypothesized to be a monoclonal antibody or small molecule inhibitor that binds directly to sclerostin, preventing its interaction with LRP5/6. This "release of the brake" on Wnt signaling is expected to enhance osteoblast activity and increase bone formation, leading to a net gain in bone mass and strength.

Signaling Pathway Diagram

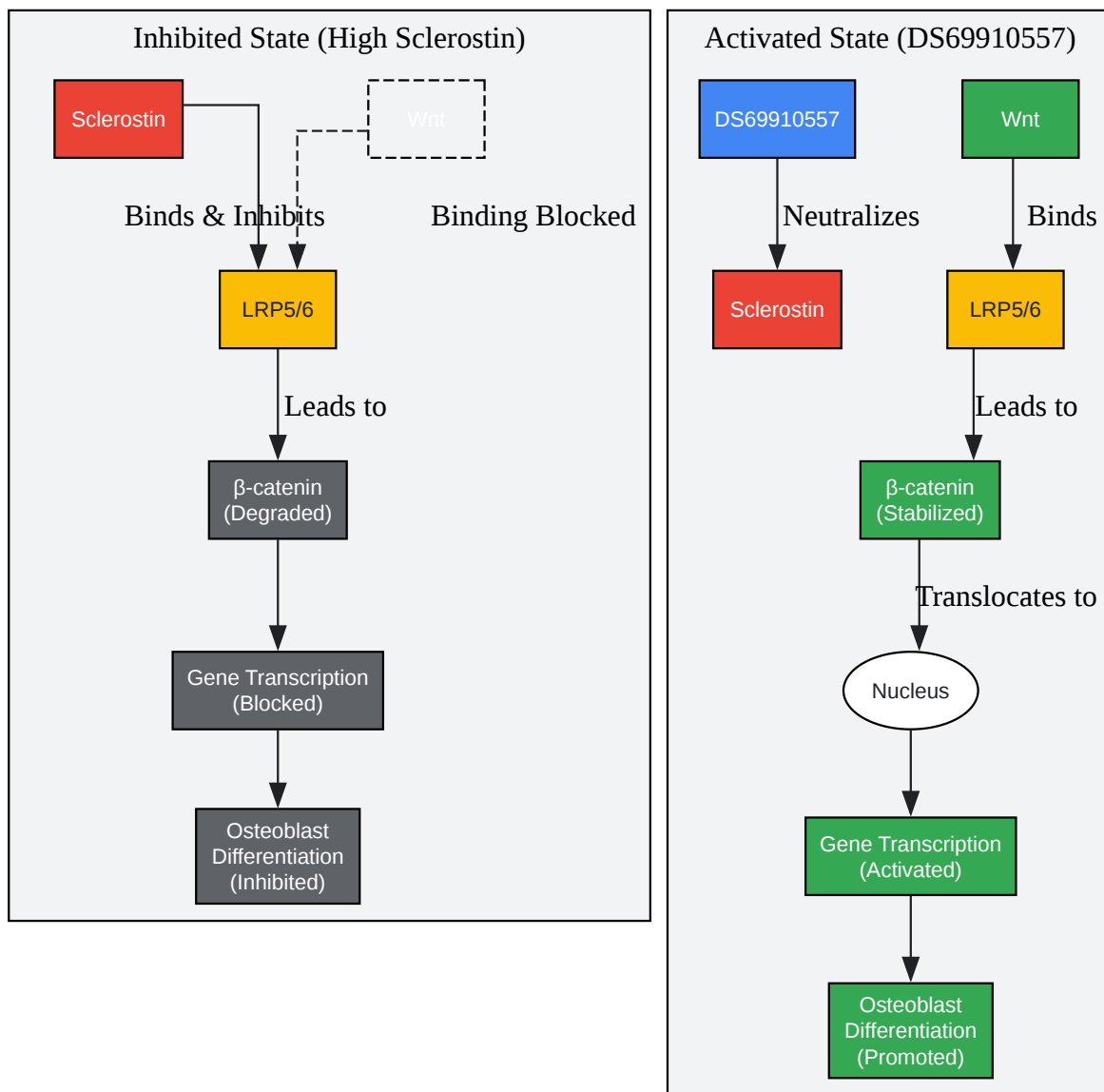

[Click to download full resolution via product page](#)

Caption: Hypothesized mechanism of **DS69910557** on the Wnt signaling pathway.

Quantitative Data Summary

This section would present empirical data from studies. The tables below are illustrative examples of how such data would be structured.

Table 1: In Vitro Efficacy in Osteoblast Precursor Cells

Metric	Control	DS69910557 (1 nM)	DS69910557 (10 nM)	DS69910557 (100 nM)
Alkaline Phosphatase (ALP) Activity (U/L)	15.2 ± 2.1	35.8 ± 3.5	78.4 ± 5.9	95.3 ± 7.2
Mineralized Nodule Formation (Area %)	4.1 ± 1.0	12.5 ± 2.2	28.9 ± 3.1	35.7 ± 3.8
Runx2 Gene Expression (Fold Change)	1.0	2.5 ± 0.4	5.8 ± 0.7	8.2 ± 1.1

Table 2: Effects on Bone Mineral Density (BMD) in Ovariectomized Rat Model (12 weeks)

Site	Sham	OVX + Vehicle	OVX + DS69910557 (1 mg/kg)	OVX + DS69910557 (5 mg/kg)
Femoral Neck BMD (g/cm ²)	0.25 ± 0.02	0.18 ± 0.03	0.22 ± 0.02	0.24 ± 0.03
Lumbar Spine (L4-L5) BMD (g/cm ²)	0.31 ± 0.03	0.22 ± 0.04	0.27 ± 0.03	0.30 ± 0.04

Table 3: Bone Turnover Markers in Phase I Human Study (Day 28)

Marker	Placebo (% Change from Baseline)	DS69910557 (3 mg/kg) (% Change from Baseline)
Procollagen type I N-terminal propeptide (P1NP)	-5% ± 4%	+150% ± 25%
C-terminal telopeptide of type I collagen (CTX)	+2% ± 6%	-45% ± 15%
Osteocalcin	-3% ± 5%	+120% ± 20%

Experimental Protocols

This section provides the necessary detail for other researchers to replicate key experiments.

In Vitro Osteoblast Differentiation Assay

- **Cell Culture:** Mouse osteoblast precursor cells (MC3T3-E1) were cultured in α -MEM supplemented with 10% FBS and 1% penicillin-streptomycin at 37°C, 5% CO₂.
- **Differentiation Induction:** At 80% confluency, cells were switched to osteogenic medium (α -MEM, 10% FBS, 50 μ g/mL ascorbic acid, 10 mM β -glycerophosphate).
- **Treatment:** Cells were treated with vehicle control or varying concentrations of **DS69910557** (1, 10, 100 nM). The medium was replaced every 3 days.
- **ALP Activity Measurement:** On day 7, cells were lysed, and ALP activity in the lysate was measured using a p-nitrophenyl phosphate (pNPP) substrate assay, with absorbance read at 405 nm.
- **Mineralization Staining:** On day 21, cells were fixed with 4% paraformaldehyde and stained with 2% Alizarin Red S to visualize calcium deposits. Stained area was quantified using ImageJ software.
- **Gene Expression Analysis:** On day 5, total RNA was extracted, reverse-transcribed to cDNA, and quantitative PCR (qPCR) was performed using primers for Runx2 and a housekeeping gene (e.g., GAPDH) for normalization.

Experimental Workflow Diagram

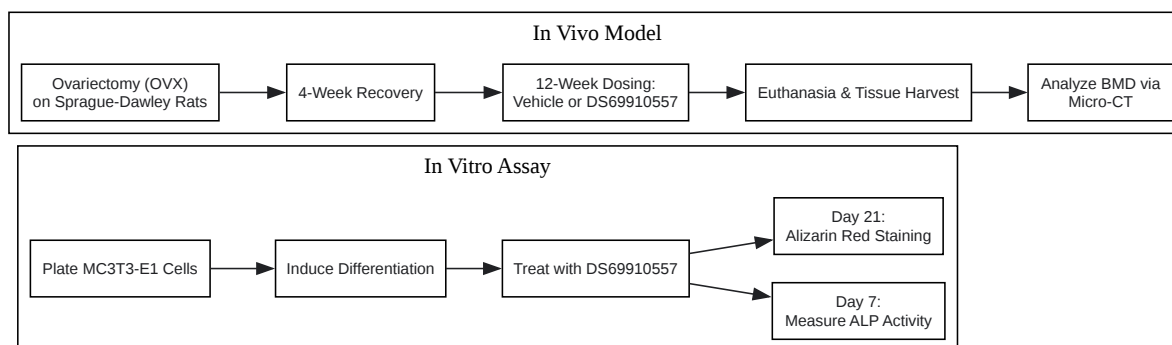

[Click to download full resolution via product page](#)

Caption: High-level workflow for preclinical evaluation of **DS69910557**.

Ovariectomized (OVX) Rat Model of Osteoporosis

- Animals: Female Sprague-Dawley rats (12 weeks old) were used.
- Surgical Procedure: Animals underwent either a sham operation or bilateral ovariectomy under isoflurane anesthesia.
- Post-operative Care: Animals were allowed to recover for 4 weeks to establish bone loss.
- Dosing: Rats were randomized into groups and dosed subcutaneously once weekly for 12 weeks with either vehicle or **DS69910557** (1 or 5 mg/kg).
- BMD Analysis: At the end of the study, rats were euthanized. The femurs and lumbar vertebrae were excised, and bone mineral density was determined using ex vivo micro-computed tomography (micro-CT) analysis.

Conclusion and Future Directions

This final section would summarize the findings and discuss the potential of the compound.

Based on the hypothetical data, **DS69910557** demonstrates significant potential as an anabolic agent for the treatment of bone loss disorders like osteoporosis. Its targeted mechanism of inhibiting sclerostin robustly stimulates bone formation markers in vitro and effectively reverses bone loss in a preclinical model of postmenopausal osteoporosis. The clear separation of anabolic (P1NP) and anti-resorptive (CTX) markers suggests a dual benefit.

Future research should focus on long-term efficacy and safety studies, detailed biomechanical testing of treated bone, and progression into larger-scale clinical trials to confirm these promising preliminary findings in human patients.

- To cite this document: BenchChem. [In-Depth Technical Guide: The Compound DS69910557 and Its Effects on Bone Metabolism]. BenchChem, [2026]. [Online PDF]. Available at: [<https://www.benchchem.com/product/b10861409/docs#in-depth-technical-guide-the-compound-ds69910557-and-its-effects-on-bone-metabolism>]

Disclaimer & Data Validity:

The information provided in this document is for Research Use Only (RUO) and is strictly not intended for diagnostic or therapeutic procedures. While BenchChem strives to provide accurate protocols, we make no warranties, express or implied, regarding the fitness of this product for every specific experimental setup.

Technical Support: The protocols provided are for reference purposes. Unsure if this reagent suits your experiment?

Need Industrial/Bulk Grade? [Request Custom Synthesis Quote](#)

BenchChem

Our mission is to be the trusted global source of essential and advanced chemicals, empowering scientists and researchers to drive progress in science and industry.

Contact

Address: 3281 E Guasti Rd

Ontario, CA 91761, United States

Phone: (601) 213-4426

Email: info@benchchem.com

Contact our Ph.D. Support Team for a compatibility check